

Dual Channel Waveform Processing Airborne LiDAR Scanning System for High Point Density Mapping and Ultra-Wide Area Mapping

RIEGL VQ-1560 II

- *high laser pulse repetition rate up to 4 MHz*
- *up to 2.66 million measurements per second on the ground*
- *offers highly efficient data acquisition at a wide range of point densities*
- *two waveform processing LiDAR channels offering excellent multiple target detection capability*
- *enables Multiple-Time-Around (MTA) processing of up to 35 pulses simultaneously in the air*
- *excellent suppression of atmospheric clutter*
- *online waveform processing as well as smart and full waveform recording*
- *integrated inertial measurement unit and GNSS receiver*
- *integrated, easily accessible medium format camera*
- *prepared for integration of a secondary camera*
- *high-speed fiber data interface to RIEGL data recorder*
- *housing shape and mounting flange optimized for interfacing with typical hatches and stabilized platforms*
- *detachable handgrips for facilitated handling*

The Dual LiDAR Waveform Processing Airborne Scanning System VQ-1560 II provides further increased performance and highest productivity based on a laser pulse repetition rate of up to 4 MHz, resulting in more than 2.66 million measurements per second on the ground.

Typical operating flight altitudes vary from less than 1,500 ft up to 12,100 ft (@ target reflectance of >20%). Laser pulse repetition rates can be tuned in steps of less than 12 kHz.

In combination with different laser power modes subtle optimization of acquisition parameters is possible in order to meet specific project requirements.

These features make the instrument the most flexible choice for acquisition of scan data with an exceptionally wide range of achievable point densities and utmost data collection efficiency at the same time. The unique forward/backward scan angle of the VQ-1560 II with its large field of view of 58 degrees enables capturing data from multiple angles more effectively and more accurately at high point densities.

The system is equipped with a seamlessly integrated high performance IMU/GNSS unit and e.g. an optional 150 megapixel RGB camera integrated in the primary camera bay.

Optionally, a second camera, e.g. a thermal camera or a 150 megapixels near-infrared camera, can be integrated on request. The design of the compact housing features a mounting flange for interfacing with typical hatches or gyro-stabilized leveling mounts.

Applications:

- *Ultra Wide Area / High Altitude Mapping*
- *Ultra-High Point Density Mapping*
- *Mapping of Complex Urban Environments*
- *Glacier & Snowfield Mapping*
- *City Modeling*
- *Mapping of Lakesides & River Banks*
- *Agriculture & Forestry*
- *Corridor Mapping*

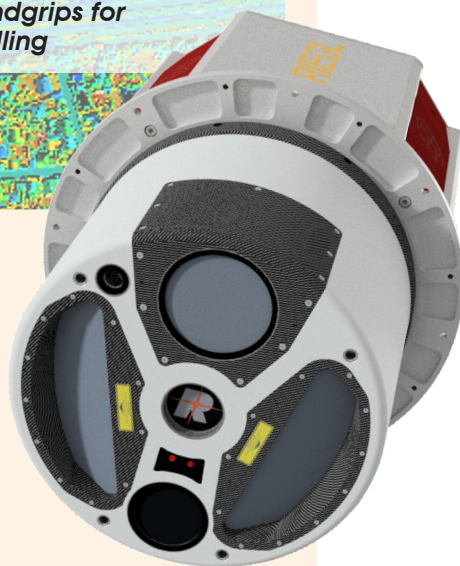

visit our website
www.riegl.com

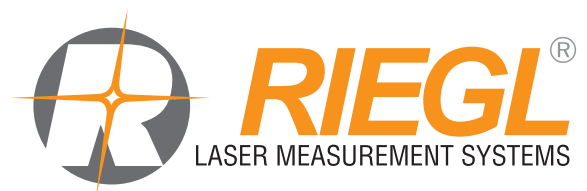

RIEGL VQ-1560 II Scan Pattern

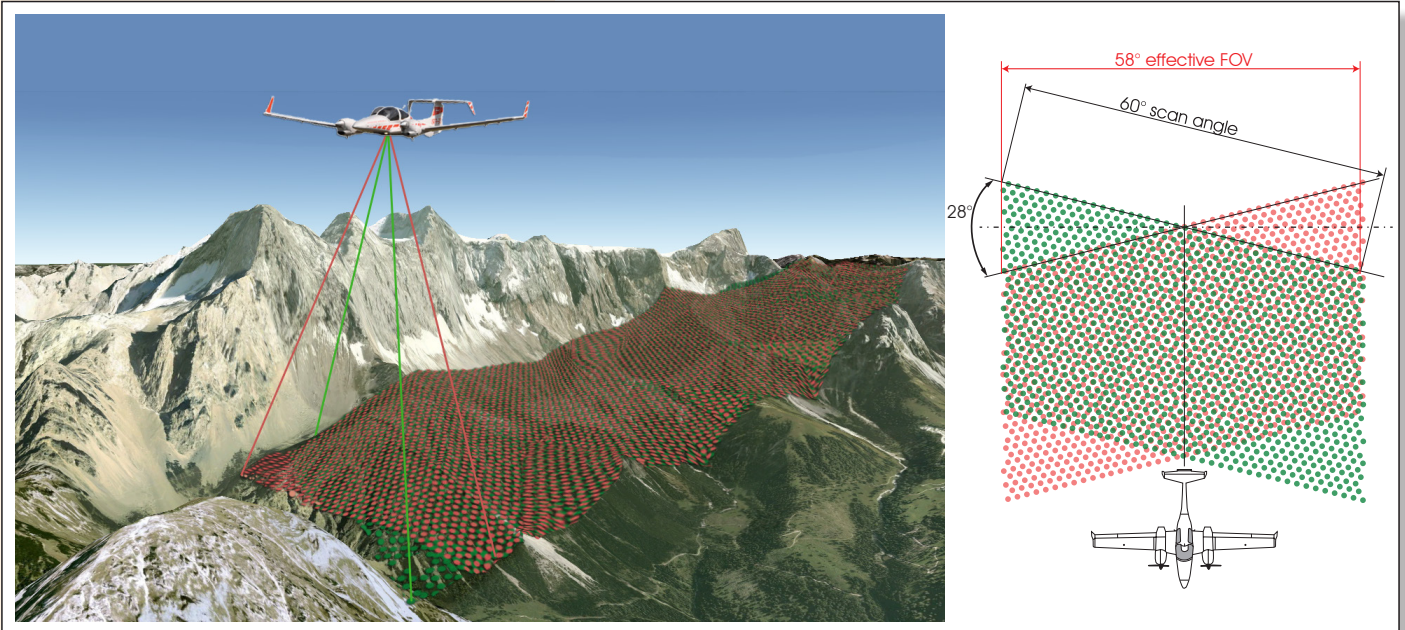

Each channel delivers straight parallel scan lines. The scan lines of the two channels are tilted against each other by 28 degrees providing an optimum distribution of the measurements on the ground invariant to changes in terrain height.

Tilt Angle of Scan Lines	$\pm 14^\circ$
Forward/Backward Scan Angle in Non-Nadir Direction	$\pm 8^\circ$ at the edge

RIEGL VQ-1560 II Elements of Function and Operation

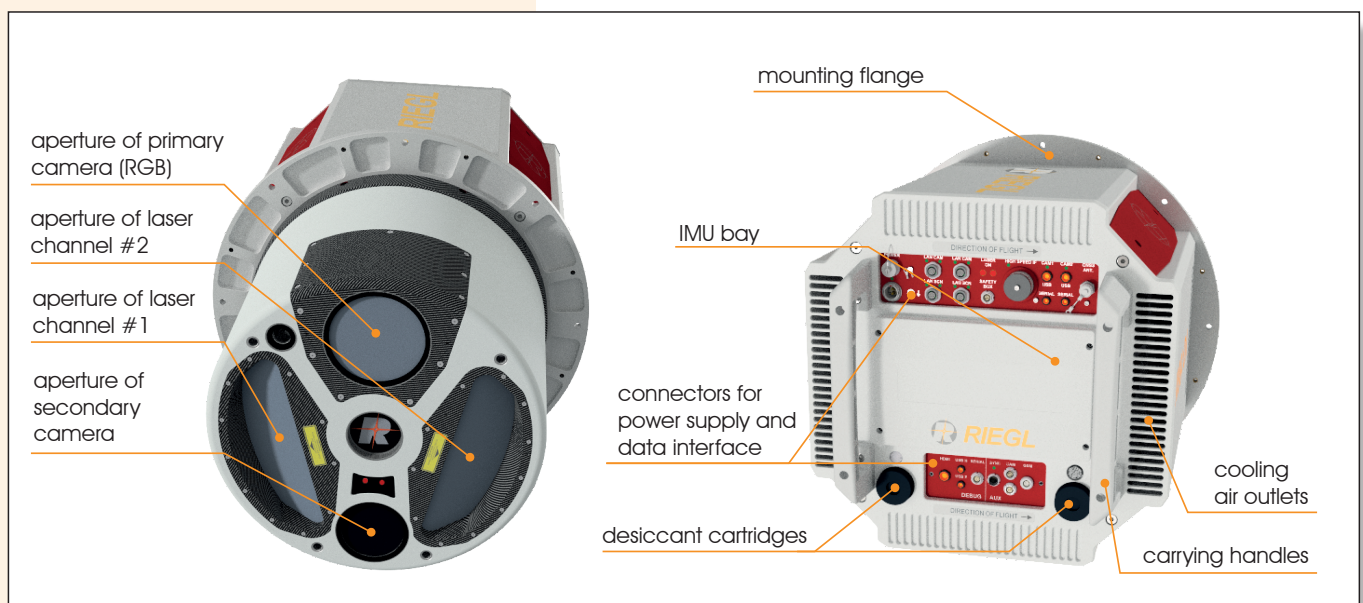

bottom view

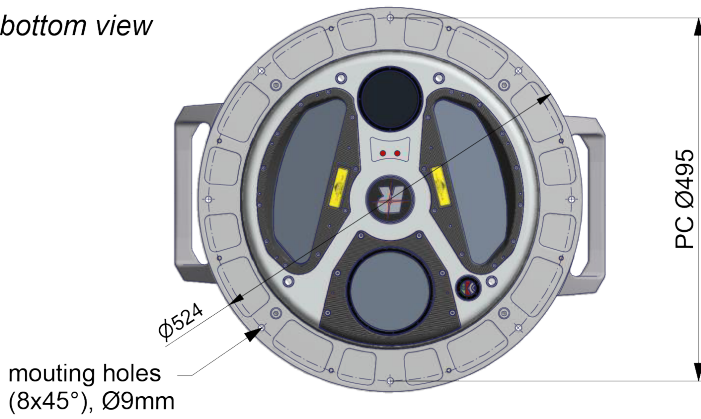

side view

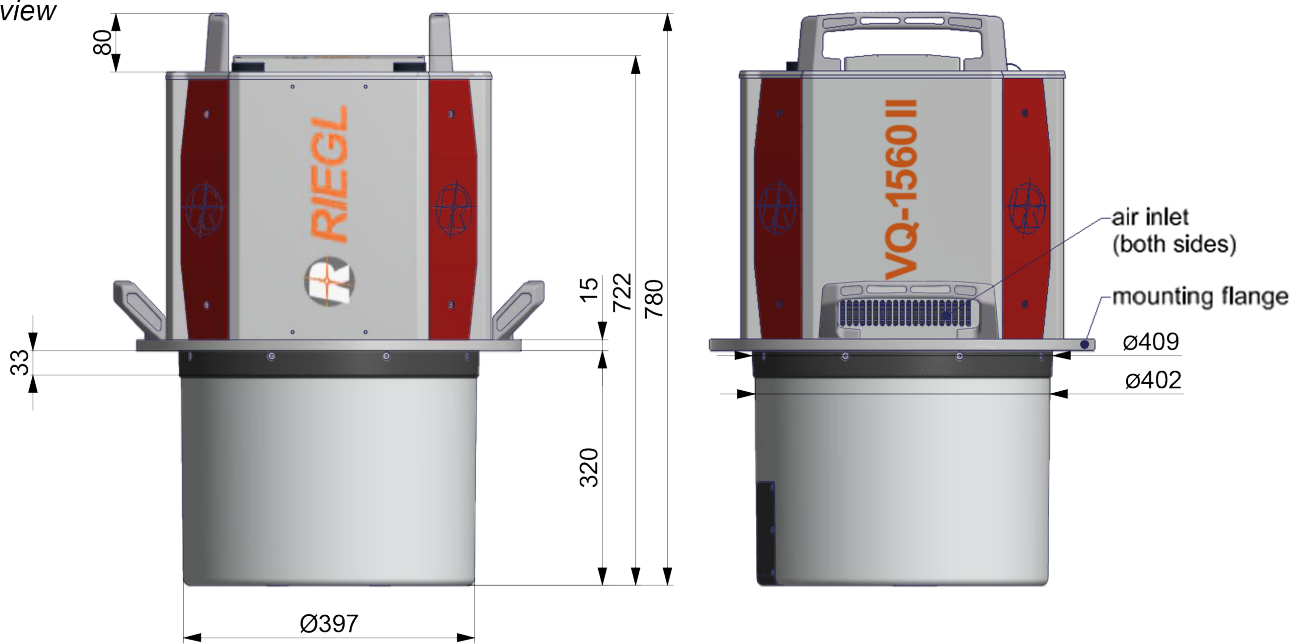

top view

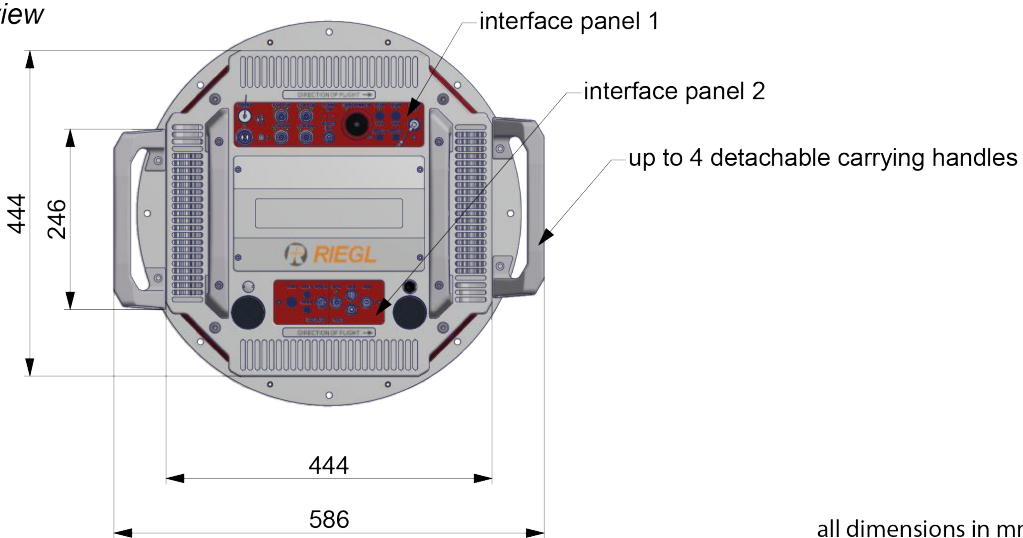

all dimensions in mm

RIEGL VQ-1560 II System Components

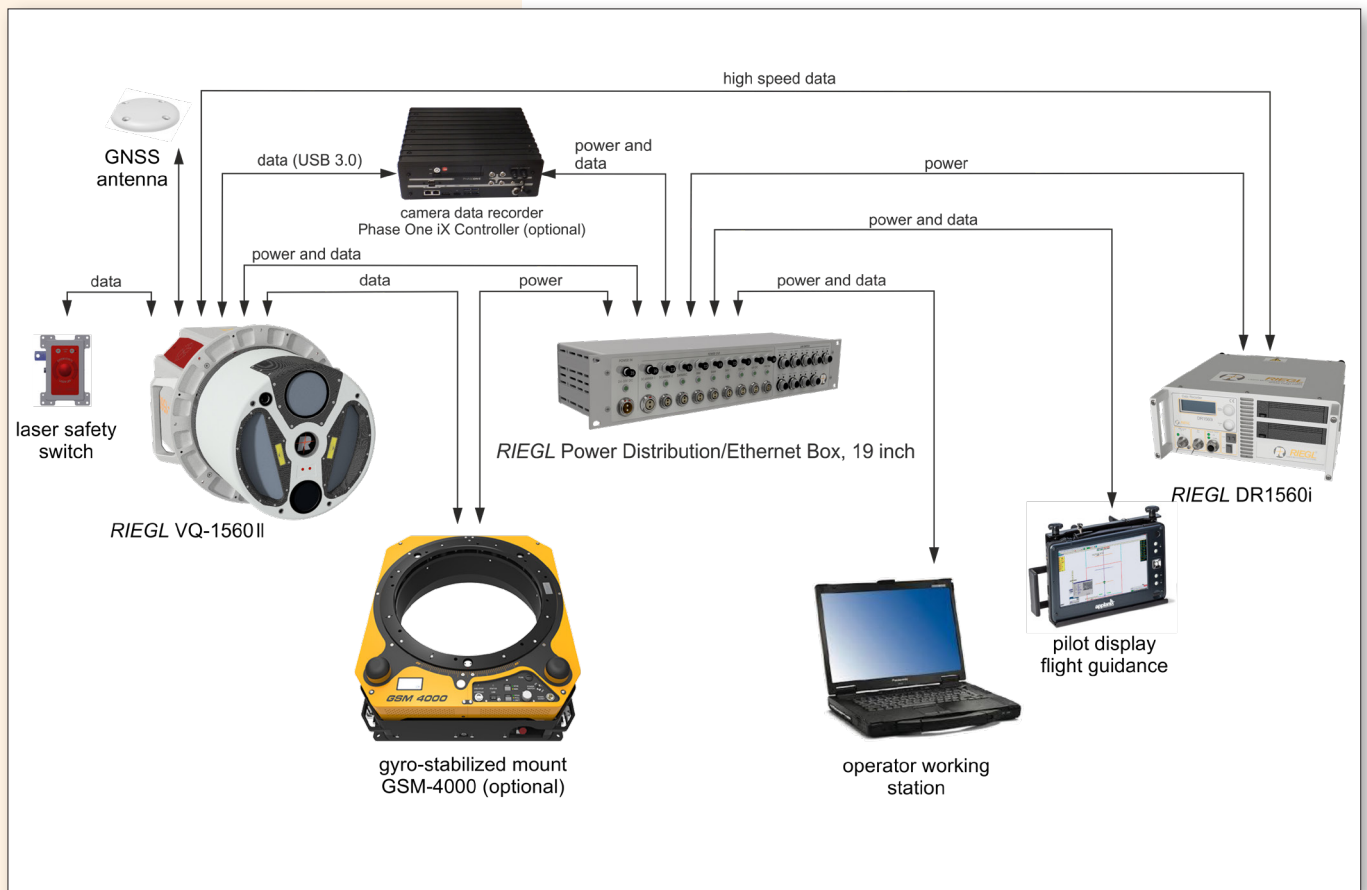

A minimum number of system components and external cabling is required for an easy and quick installation in aircrafts.

RIEGL VQ-1560 II Installation Examples



RIEGL VQ-1560 II installed in the nose pod of fixed-wing aircraft DA42 MPP



RIEGL VQ-1560 II installed on GSM-4000 gyro-stabilized platform to be used in a helicopter or fixed-wing aircraft

Measurement Range & Point Density RIEGL VQ-1560 II

Laser PRR = 2x150kHz, laser power level 100%

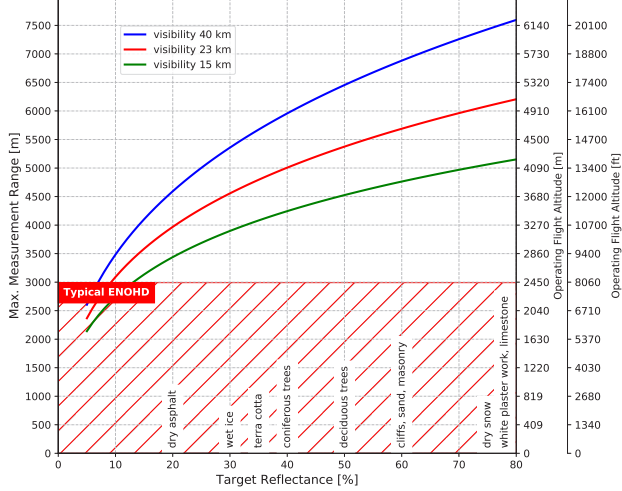

Example: VQ-1560 II at 2 x 150,000 pulses/sec, laser power level 100%
Altitude 14,900 ft AGL, Speed 150 kn

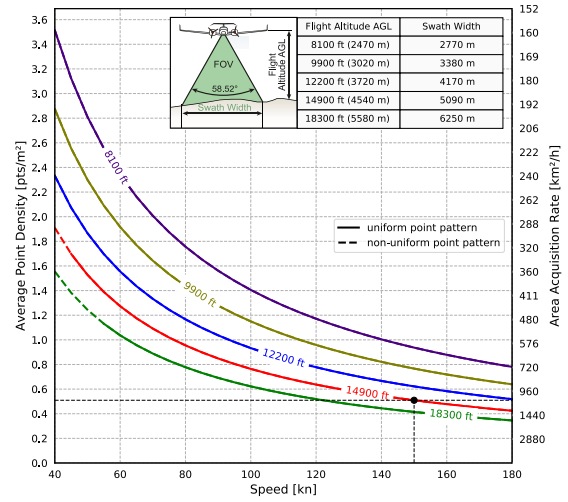

Results: Point Density ~ 0.51 pts/m²
Area Acquisition Rate ~ 1130 km²/h

Laser PRR = 2x250kHz, laser power level 100%

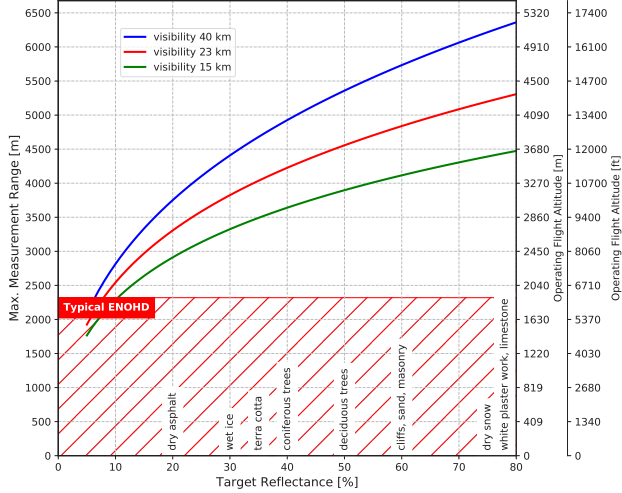

Example: VQ-1560 II at 2 x 250,000 pulses/sec, laser power level 100%
Altitude 12,100 ft AGL, Speed 140 kn

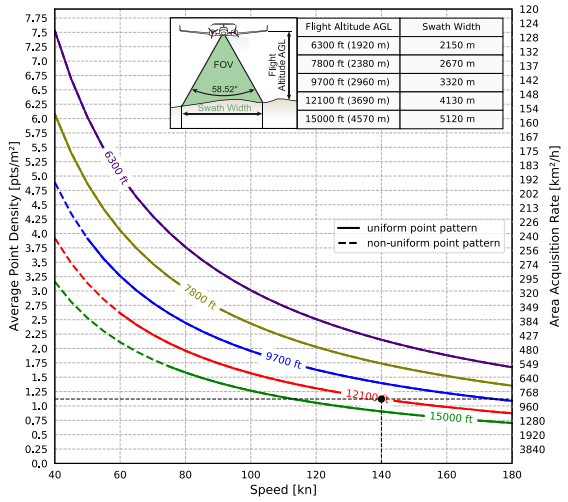

Results: Point Density ~ 1.12 pts/m²
Area Acquisition Rate ~ 857 km²/h

Laser PRR = 2x500kHz, laser power level 100%

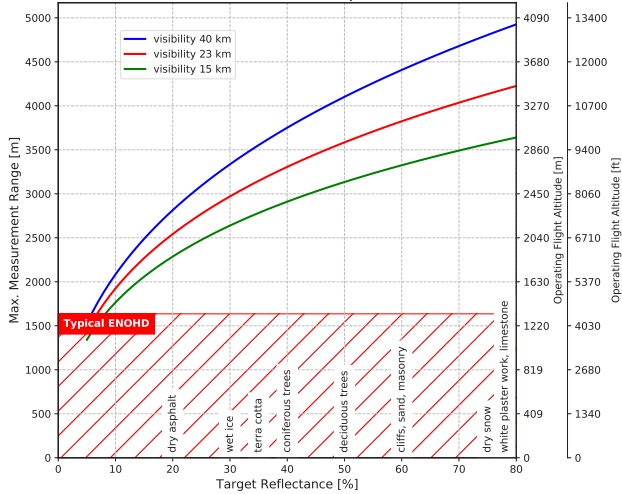

Example: VQ-1560 II at 2 x 500,000 pulses/sec, laser power level 100%
Altitude 7,100 ft AGL, Speed 130 kn

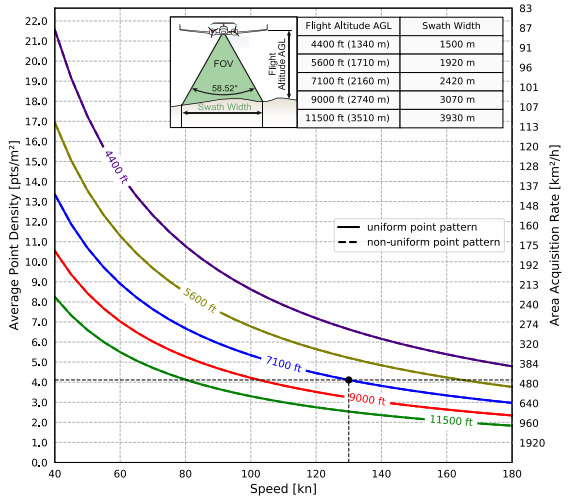

Results: Point Density ~ 4.12 pts/m²
Area Acquisition Rate ~ 467 km²/h

The following conditions are assumed for the Operating Flight Altitude AGL

- ambiguity resolved by multiple-time-around (MTA) processing
- target size ≥ laser footprint
- effective FOV 58°
- average ambient brightness
- roll angle ±5°

Assumptions for calculation of the Area Acquisition Rate

- 20% overlap of neighboring flight strips. This overlap covers a roll angle of ±5° or a reduction of flight altitude AGL of 20%.

Typical ENOHD

- Calculated under assumption of an angular step width of 0.012° and an aircraft speed higher than 10kn.

Measurement Range & Point Density RIEGL VQ-1560 II

Laser PRR = 2x1000kHz, laser power level 100%

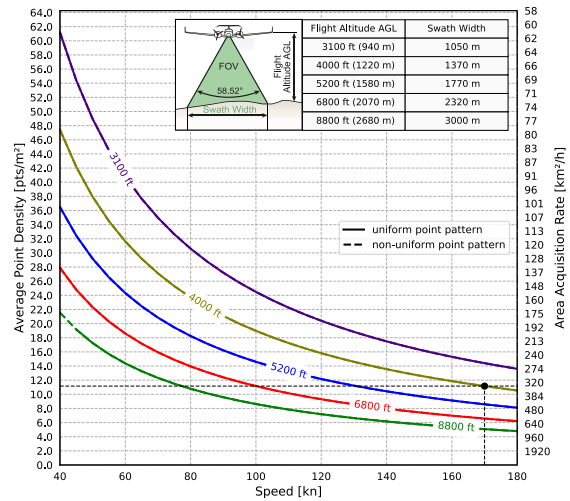
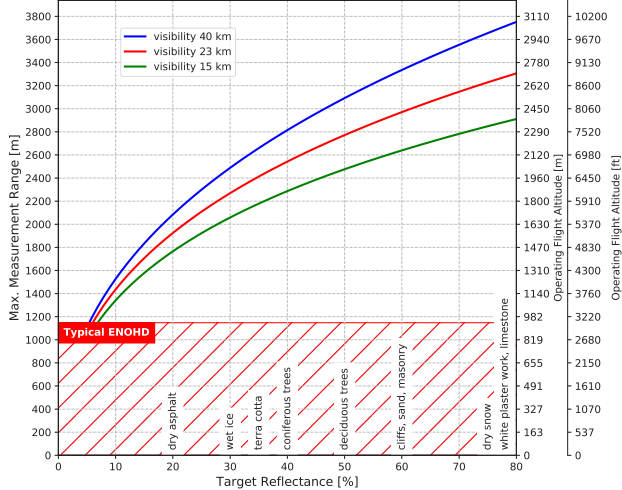

Example: VQ-1560 II at 2 x 1,000,000 pulses/sec, laser power level 100%
Altitude 4,000 ft AGL, Speed 170 kn

Results: Point Density ~ 11.1 pts/m²
Area Acquisition Rate ~ 344 km²/h

Laser PRR = 2x2000kHz, laser power level 100%

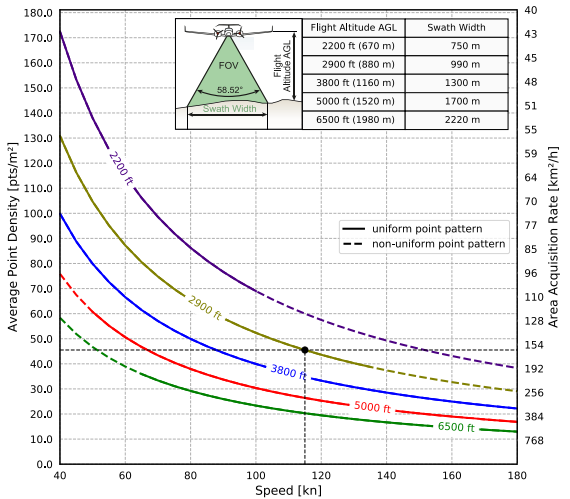
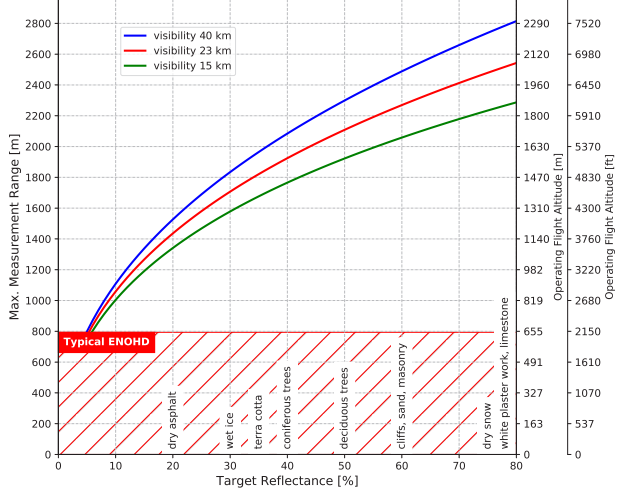

Example: VQ-1560 II at 2 x 2,000,000 pulses/sec, laser power level 100%
Altitude 2,900 ft AGL, Speed 115 kn

Results: Point Density ~ 45 pts/m²
Area Acquisition Rate ~ 169 km²/h

Laser PRR = 2x2000kHz, laser power level 50%

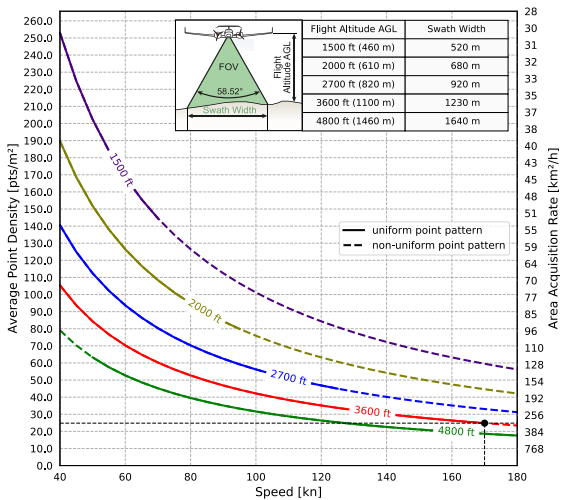
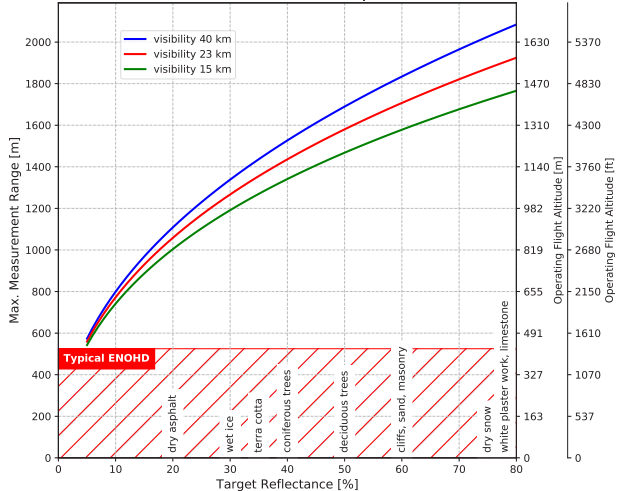

Example: VQ-1560 II at 2 x 2,000,000 pulses/sec, laser power level 50%
Altitude 3,600 ft AGL, Speed 170 kn

Results: Point Density ~ 24.8 pts/m²
Area Acquisition Rate ~ 310 km²/h

The following conditions are assumed for the Operating Flight Altitude AGL

- ambiguity resolved by multiple-time-around (MTA) processing
- target size ≥ laser footprint
- effective FOV 58°
- average ambient brightness
- roll angle ±5°

Assumptions for calculation of the Area Acquisition Rate

- 20% overlap of neighboring flight strips. This overlap covers a roll angle of ±5° or a reduction of flight altitude AGL of 20%.

Typical ENOHD

- Calculated under assumption of an angular step width of 0.012° and an aircraft speed higher than 10kn.

Measurement Range & Point Density RIEGL VQ-1560 II

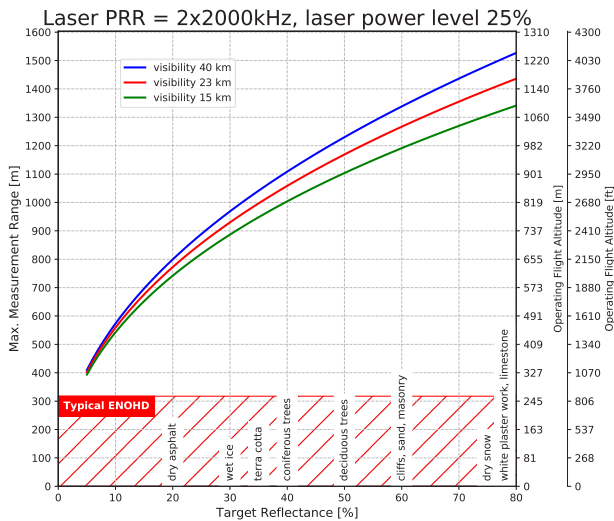

Example: VQ-1560 II at 2 x 2,000,000 pulses/sec, laser power level 25%
Altitude 3,400 ft AGL, Speed 120 kn

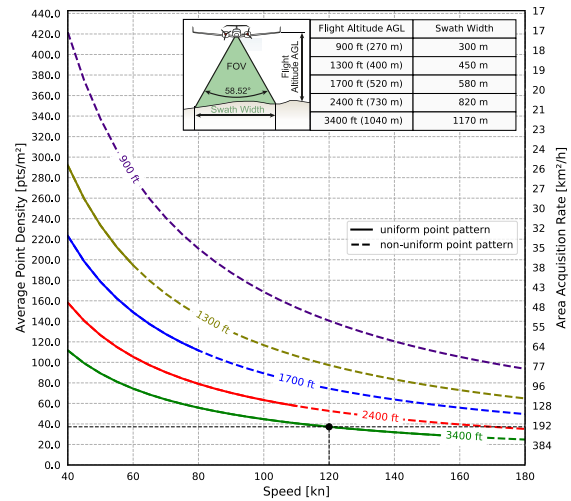

Results: Point Density ~ 37 pts/m²
Area Acquisition Rate ~ 207 km²/h

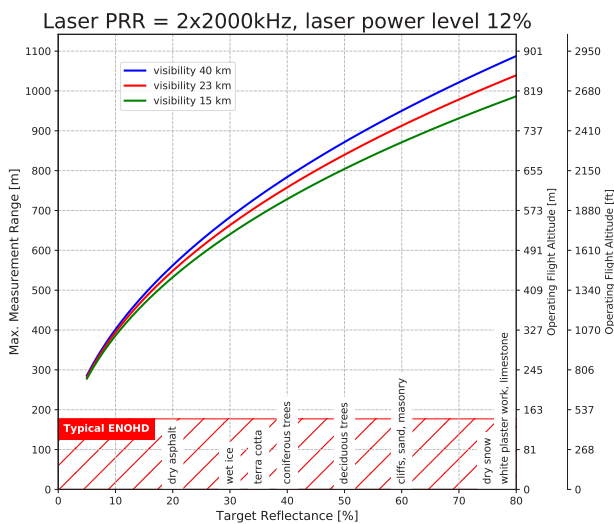

Example: VQ-1560 II at 2 x 2,000,000 pulses/sec, laser power level 12%
Altitude 2,500 ft AGL, Speed 100 kn

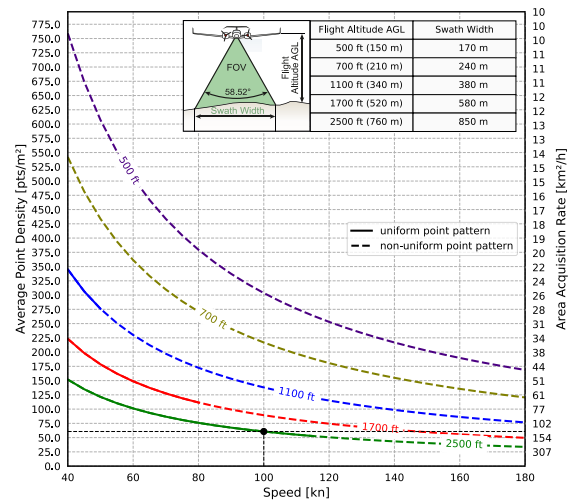

Results: Point Density ~ 61 pts/m²
Area Acquisition Rate ~ 127 km²/h

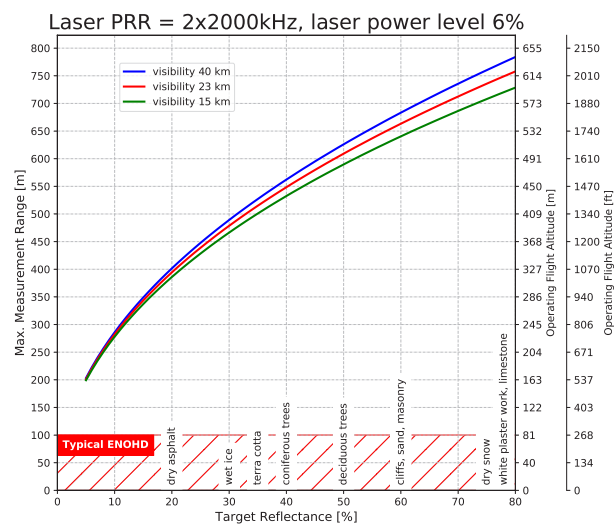

Example: VQ-1560 II at 2 x 2,000,000 pulses/sec, laser power level 6%
Altitude 1,800 ft AGL, Speed 85 kn

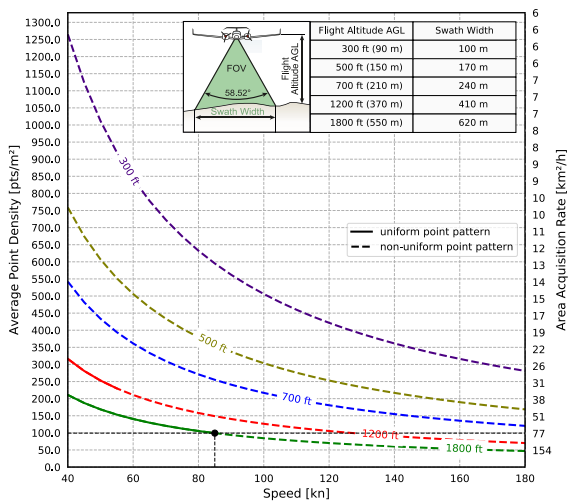

Results: Point Density ~ 99 pts/m²
Area Acquisition Rate ~ 77 km²/h

The following conditions are assumed for the Operating Flight Altitude AGL

- ambiguity resolved by multiple-time-around (MTA) processing
- target size ≥ laser footprint
- effective FOV 58°
- average ambient brightness
- roll angle ±5°

Assumptions for calculation of the Area Acquisition Rate

- 20% overlap of neighboring flight strips. This overlap covers a roll angle of ±5° or a reduction of flight altitude AGL of 20%.

Typical ENOHD

- Calculated under assumption of an angular step width of 0.012° and an aircraft speed higher than 10kn.

RIEGL VQ-1560 II Productivity

The RIEGL VQ-1560 II Dual Channel Airborne Mapping System offers highest productivity.

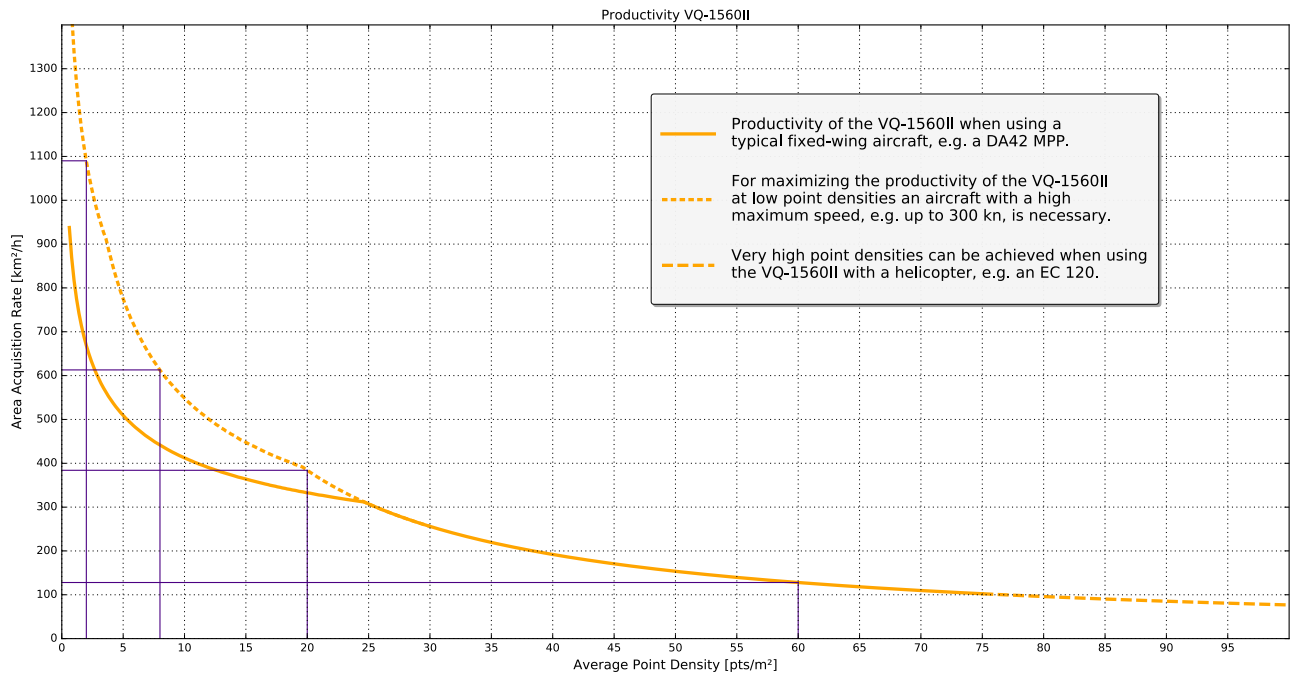

Examples ¹⁾

Average Point Density	2 pts/m ²	8 pts/m ²	20 pts/m ²	60 pts/m ²
Flight Altitude	7200 ft 2200 m	4040 ft 1230 m	4000 ft 1220 m	2450 ft 750 m
Ground Speed	300 kn	300 kn	190 kn	103 kn
Swath Width	2450 m	1380 m	1360 m	840 m
Productivity	1090 km ² /h	613 km ² /h	384 km ² /h	128 km ² /h
Measurement Rate ²⁾	756 000 meas./sec	1.7 mill meas./sec	2.66 mill meas./sec	2.66 mill meas./sec
Camera GSD ^{3) 4)}	165 mm	93 mm	92 mm	56 mm
Camera Trigger Intervall ⁴⁾	4,6 sec	2,6 sec	4,0 sec	4,5 sec

1) calculated for 20% target reflectivity and 20% stripe overlap

2) The target detection rate is equal to the measurement rate for terrains offering only one target per laser pulse but may be much higher for vegetated areas.

3) Ground Sampling Distance

4) Calculated for a 150 MPixel CMOS camera with a FOV of 56.2° x 43.7° and 60% image overlap in flight direction (endlap).

Technical Data RIEGL VQ-1560 II

Laser Product Classification

Class 3B Laser Product according to IEC60825-1:2014
The following clause applies for instruments delivered into the United States: Complies with 21 CFR 1040.10 and 1040.11 except for conformance with IEC 60825-1 Ed.3., as described in Laser Notice No. 56, dated May 8, 2019.

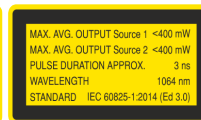

The instrument must be used only in combination with the appropriate laser safety box.

Range Measurement Performance

as a function of laser power setting, PRR, and target reflectivity

Laser Power Level	100%				
Laser Pulse Repetition Rate (PRR) ¹⁾	2 x 150 kHz	2 x 250 kHz	2 x 500 kHz	2 x 1000 kHz	2 x 2000 kHz
Max. Measuring Range ^{2) 3) 4)}					
natural targets $\rho \geq 20\%$	4500 m	3700 m	2800 m	2050 m	1500 m
natural targets $\rho \geq 60\%$	6800 m	5600 m	4300 m	3300 m	2450 m
Max. Operating Flight Altitude ^{2) 5)} (AGL) ⁶⁾					
natural targets $\rho \geq 20\%$	3700 m 12100 ft	3000 m 9900 ft	2300 m 7500 ft	1700 m 5500 ft	1200 m 4000 ft
natural targets $\rho \geq 60\%$	5600 m 18300 ft	4600 m 15000 ft	3500 m 11500 ft	2700 m 8800 ft	2000 m 6500 ft
NOHD ^{7) 9)}	370 m	290 m	200 m	140 m	95 m
ENOHD ^{8) 9)}	2450 m	1900 m	1340 m	940 m	650 m
Number of Targets per Laser Pulse up to ¹⁰⁾	14	14	14	9	4

Laser Power Level	50%	25%	12%	6%
Laser Pulse Repetition Rate (PRR) ¹⁾	2 x 2000 kHz	2 x 2000 kHz	2 x 2000 kHz	2 x 2000 kHz
Max. Measuring Range ^{2) 3) 4)}				
natural targets $\rho \geq 20\%$	1100 m	780 m	560 m	400 m
natural targets $\rho \geq 60\%$	1800 m	1300 m	940 m	680 m
Max. Operating Flight Altitude ^{2) 5)} (AGL) ⁶⁾				
natural targets $\rho \geq 20\%$	900 m 3000 ft	640 m 2100 ft	460 m 1500 ft	330 m 1080 ft
natural targets $\rho \geq 60\%$	1450 m 4800 ft	1050 m 3400 ft	770 m 2500 ft	550 m 1800 ft
NOHD ^{7) 9)}	61 m	37 m	21 m	12 m
ENOHD ^{8) 9)}	430 m	270 m	145 m	82 m
Number of Targets per Laser Pulse up to ¹⁰⁾	4	4	4	4

1) rounded average PRR

2) Typical values for average conditions and average ambient brightness; in bright sunlight the operational range may be considerably shorter and the operational flight altitude may be considerably lower than under an overcast sky.

3) The maximum range is specified for flat targets with size in excess of the laser beam diameter, perpendicular angle of incidence, and for atmospheric visibility of 40 km. Range ambiguities have to be resolved by multiple-time-around processing.

4) If the laser beam hits, in part, more than one target, the laser's pulse power is split accordingly. Thus, the achievable range is reduced.

5) Typical values for max. effective FOV 58°, additional roll angle $\pm 5^\circ$

6) Above Ground Level

7) Nominal Ocular Hazard Distance, based upon MPE according to IEC 60825-1:2014, for single line condition

8) Extended Nominal Ocular Hazard Distance, based upon MPE according to IEC 60825-1:2014, for single line condition

9) NOHD and ENOHD have been calculated for a typical angular step width of 0.012° (which means non-overlapping laser footprints), and an aircraft speed higher than 10 kn. NOHD and ENOHD increase when using overlapping laser footprints which may be intended e.g. for power line mapping.

10) when using online waveform processing

Minimum Range ¹¹⁾

Accuracy ^{12) 13)} / Precision ^{13) 14)}

Laser Pulse Repetition Rate ¹⁵⁾

Effective Measurement Rate

Echo Signal Intensity

Laser Wavelength

Laser Beam Divergence

100 m

20 mm / 20 mm

2 x 150kHz up to 2 x 2000kHz, selectable in steps of less than 1%

up to 2 x 1.33 MHz @ 60° scan angle

provided for each echo signal

near infrared

≤ 0.18 mrad @ $1/e^{16}$, ≤ 0.25 mrad @ $1/e^2$ ¹⁷⁾

Scanner Performance

Scanning Mechanism

Scan Pattern

Tilt Angle of Scan Lines

Forward/ Backward Scan Angle

in Non-Nadir Direction

Scan Angle Range

Total Scan Rate

Angular Step Width $\Delta\theta$

Angle Measurement Resolution

rotating polygon mirror

parallel scan lines per channel, crossed scan lines between channels

$\pm 14^\circ = 28^\circ$

$\pm 8^\circ$ at the edges

60° total per channel, resulting in an effective FOV of 58°

40 ¹⁸⁾ - 600 lines/sec

$0.006^\circ \leq \Delta\theta \leq 0.180^\circ$ ^{19) 20)}

0.001°

11) Limitation for range measurement capability, does not consider laser safety issues! The minimum range for valid reflectivity values is 250 m.

12) Accuracy is the degree of conformity of a measured quantity to its actual (true) value.

13) Standard deviation one sigma @ 250 m range under RIEGL test conditions.

14) Precision, also called reproducibility or repeatability, is the degree to which further measurements show the same result.

15) For smart and full waveform recording the max. laser PRR is limited to 2 x 1600kHz.

16) Measured at the $1/e$ points. 0.18 mrad correspond to an increase of 18 cm of beam diameter per 1000 m distance.

17) Measured at the $1/e^2$ points. 0.25 mrad correspond to an increase of 25 cm of beam diameter per 1000 m distance.

18) The minimum scan rate depends on the selected laser PRR.

19) The minimum angular step width depends on the selected laser PRR.

20) The maximum angular step width is limited by the maximum scan rate.

Technical Data to be continued at page 10

Technical Data *RIEGL VQ-1560 II* (continued)

Data Interfaces

Configuration
Monitoring Data Output
Digitized Data Output
Synchronization

TCP/IP Ethernet (10/100/1000 MBit/s)
TCP/IP Ethernet (10/100/1000 MBit/s)
Dual glass fiber data link to *RIEGL* Data Recorder DR1560i
Serial RS-232 interface, TTL input for 1 pps synchronization pulse,
accepts different data formats for GNSS-time information

General Technical Data

Power Supply / Power Consumption

20 - 32 V DC / typ. 250 W
max. 550 W, depending on integrated optional components
Ø 524 mm x 780 mm (without flange mounted carrying handles)
approx. 55 kg without any camera but including a typical IMU/GNSS unit
approx. 60 kg with optional components

Main Dimensions (flange diameter x height)
Weight

Protection Class

IP54

Max. Flight Altitude operating / not operating
Temperature Range operation / storage

18500 ft (5600 m) above MSL¹⁾ / 18500 ft (5600 m) above MSL
-5°C up to +40°C / -10°C up to +50°C

1) Mean Sea Level

Recommended IMU/GNSS System ^{2) 3)}

IMU Accuracy ⁴⁾

Roll, Pitch

0.0025°

Heading

0.005°

IMU Sampling Rate

200 Hz

Position Accuracy (typ.)

0.05 m - 0.1 m

Optional Components VQ-1560II

Primary Camera

Sensor Resolution
Sensor Dimensions (diagonal)
Focal Length of Camera Lens
Field of View (FOV)
Interface
Data Storage

RGB
e.g. 150 MPixel CMOS
66.7 mm (medium format)
50 mm
approx. 54.6° x 42.3°
USB 3.0
iX-Controller

Secondary Camera

Different camera types including thermal or NIR cameras can be integrated,
details on request.

2) The recommended IMU is listed neither in the European Export Control List (i.e. Annex 1 of Regulation (EU) No. 2021/821) nor in the Canadian Export Control List. Detailed information on certain cases will be provided on request.

3) The *RIEGL VQ-1560 II* Laser Scanning system supports different IMU/GNSS Systems, details on request.

4) One sigma values, no GNSS outages, post-processed with base station data



RIEGL Laser Measurement Systems GmbH
Horn, Austria
Phone: +43 2982 4211 | www.riegl.com
RIEGL USA Inc.
Winter Garden, Florida, USA
Phone: +1 407 248 9927 | www.rieglusa.com

RIEGL Japan Ltd. | www.riegl-japan.co.jp
RIEGL China Ltd. | www.riegl.cn
RIEGL Australia Pty Ltd. | www.riegl.com
RIEGL Canada Inc. | www.rieglcanada.com
RIEGL UK Ltd. | www.riegl.co.uk

www.riegl.com