

**multisys**

**D2-1DI2DO-1**



**Pulse doubler**



You can find the instructions for your KBR device at our download center.

<https://www.kbr.de/de/dienstleistungen/download-center>

## Table of Contents

1	Introduction .....	3
1.1	User Manual .....	3
1.2	Safety Keys.....	4
2	Wiring diagram .....	6
3	Technical data.....	7

**KBR Kompensationsanlagenbau GmbH** does not accept any liability for any loss or damage resulting from printing errors in or changes to this manual.

In addition, **KBR Kompensationsanlagenbau GmbH** does not accept any liability for any loss or damage caused by defective devices or devices manipulated by the user.

Copyright 2021 by **KBR Kompensationsanlagenbau GmbH**  
Subject to change.

# 1 Introduction

Thank you for choosing this KBR quality product.

To become familiar with the operation and programming of the device and to use the full range of functions of this high-quality product at all times, you should read this user manual carefully.

The individual chapters explain the technical details of the device and show how damage can be avoided through proper installation and commissioning.

## 1.1 User Manual

This user manual must be accessible to the user at all times (e.g. in the switchgear cabinet). Even if the device is resold to third parties, the manual remains an inherent part of the device.

Although the utmost care has been taken in writing this user manual, errors may still occur. We would be very grateful if you would notify us of any errors or unclear descriptions you may notice.

## 1.2 Safety Keys

This manual contains instructions that you must follow for your personal safety and to avoid material damage. These instructions are identified by a warning sign or information symbol, depending on the degree of hazard they warn about.



### DANGEROUS VOLTAGE

“Warning” means that death, major injuries or damage may occur if suitable safety precautions are not taken.



### CAUTION

“Caution” means that minor injuries or damage may occur if the appropriate safety precautions are not taken.



### NOTE

“Note” is an important piece of information on the product, its operation or the respective part of the user manual to which special reference is being made.

## Disclaimer

The contents of these user manual have been carefully reviewed in terms of the hardware and software described. However, deviations cannot be excluded and therefore, complete conformity cannot be guaranteed. The specifications made in this user manual are reviewed on a regular basis; any corrections required will be included in the next revision.

## Included in delivery:

- multisys device
- Plug set
- instruction manual

**DANGEROUS VOLTAGE****The applicable DIN/VDE regulations must be observed during installation!**

Connection to the mains, commissioning and operation of the device may only be carried out by qualified personnel. Qualified personnel within the meaning of the safety instructions in this manual are persons with electrical engineering training and knowledge of national accident prevention regulations, safety engineering standards and the installation, commissioning and operation of the device.

To prevent fire and electric shock, do not expose the device to rain or moisture!

Before connecting the device to the power supply, check whether the local power supply conditions comply with the specifications on the device nameplate.

Incorrectly connecting the device can lead to damage!

When connecting the device, adhere to the information given in the connection diagram (see "Connection diagram") and that the connecting cables are not live. When wiring, always ensure that all cables used are neither damaged nor faulty

and observe correct polarity!

Proper and safe operation of the product requires correct transport, storage, installation and assembly as well as careful operation and maintenance.

If the device has any visible damage it is considered unfit for use and must be disconnected from the mains! Troubleshooting, repairs and maintenance work may only be carried out at our plant or after contacting our customer service team.

If the device is opened without authorization, any warranty or guarantee claim is forfeited. Error-free functioning can no longer be guaranteed!

Opening the device may expose live parts. Capacitors in the device may still be charged, even if the device has been disconnected from all power sources. Do not operate open devices under any circumstances!

Lightning protection measures must be provided for all input and output cables in systems at risk from lightning strikes!

- Switching repeater for pulse doubling
- Integrated power supply
- One input - Two outputs
- Top-hat rail housing

## 2 Wiring diagram

Pulse generator (EVU meter or KBR-multimes D6-xxx-5 etc.)

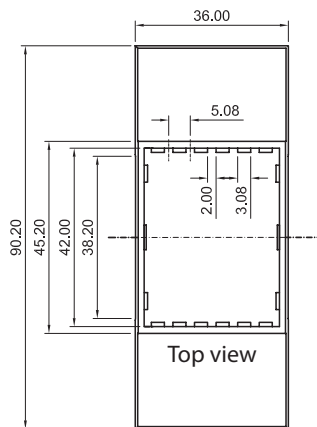
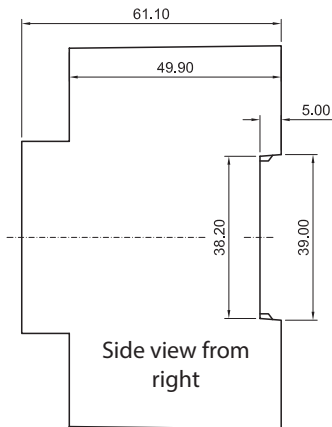
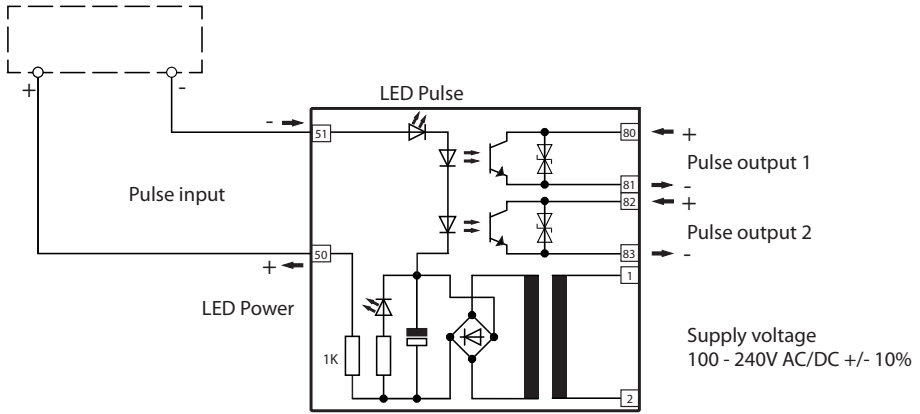

### 3 Technical data

Input data:		
Input voltage	power supply	100 – 240 V +/- 10% ,DC/50/60 Hz, max. 3,5 VA
	Power optocoupler	Switching level 1-Signal („H“) >10mA to <27mA
		Switching level 0-Signal („L“) < 2mA
Transmission frequency $f_{\text{grenz}}$ (ohmic load)		10 Hz
Input circuit	Overvoltage protection, Reverse polarity protection, RC element, Operating display (LED yellow), Voltage indicator(green)	
Output data:		
Operating voltage range		15 to 120 VDC
Continuous load current		2x 0,75 A
Voltage drop at max. load current		1,4 V DC
Output circuit		Reverse polarity protection, overvoltage protection floating, 2-wire connection

Standards and miscellaneous				
Ambient conditions	Standards	DIN EN 60721-3-3:1995-09 + DIN EN721-3-3/A2:1997-07; 3K5 +3Z11; (IEC721-3-3;3K5 + 3Z11)		
	Operating temperature	K55 (-5°C ...+55°C)		
	Air humidity	5%...95% non-condensing		
	Storage temperature	K55(-25°C...+70°C)		
	Operating height	0...2,000 m above sea level		
Electrical safety	Standards	DIN EN 61010-1:2011-07		
	Protection class	II		
	Overvoltage category	Power supply	CAT III: 300V	
	Isolation voltage	Input/ Output	4 kV	
		Output / Output	2,5 kV	
		Rated surge voltage	4 kV	
Protection type	Standards	IP 20 according to DIN EN 60529:2014-09		

**KBR Kompensationsanlagenbau GmbH**

Am Kieferschlag 7  
D-91126 Schwabach  
Germany

T +49 (0) 9122 6373-0  
F +49 (0) 9122 6373-83  
E [info@kbr.de](mailto:info@kbr.de)

[www.kbr.de](http://www.kbr.de)