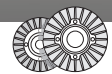

CD-Series

Compact Dual Disc Clutches

**Montalvo CD-Series Compact Dual Disc Clutches**

CD Series 100 130

CD-Series clutches are the cost-effective choice in light/medium duty tension control applications such as tag and label manufacturing, film manufacturing, slitter-rewinders, flexo printing, non-wovens/textiles, and various power transmission uses. CD-Series dual disc clutches are available in 100 and 130mm sizes. They offer multiple range control. The unique friction module may be assembled in a variety of configurations and may be purchased individually and used in conjunction with customer supplied discs. With sales and service trained representatives in all important markets, Montalvo supplies application expertise and product sales service worldwide.

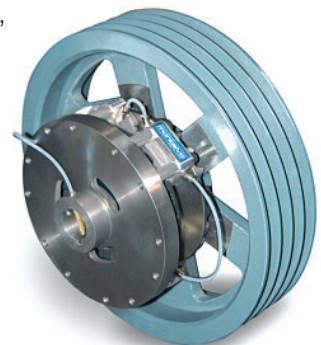

Drive pulley mounted to a CD130 clutch.

Features

- ▶ Compact
- ▶ Low inertia
- ▶ Modular design
- ▶ High thermal capacity
- ▶ Wide torque range & capacity
- ▶ Easy installation & maintenance

CD-Series

Compact Dual Disc Clutches

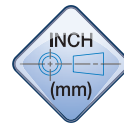

Dimensions

CD100

(CD104 shown)

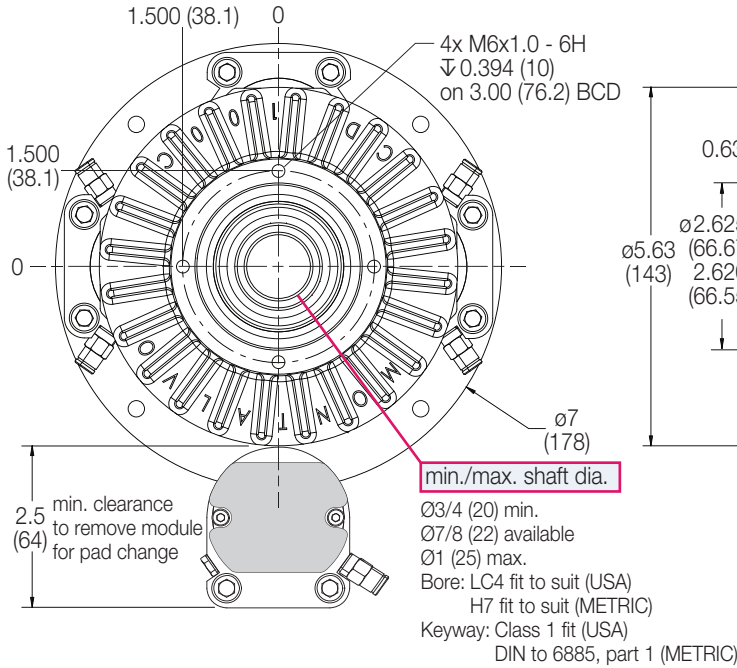
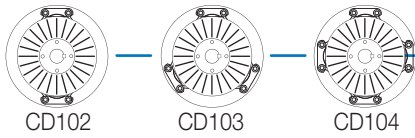

Air Transfer Cap Option (when ATC is used, drilling & tapping the shaft is not required)

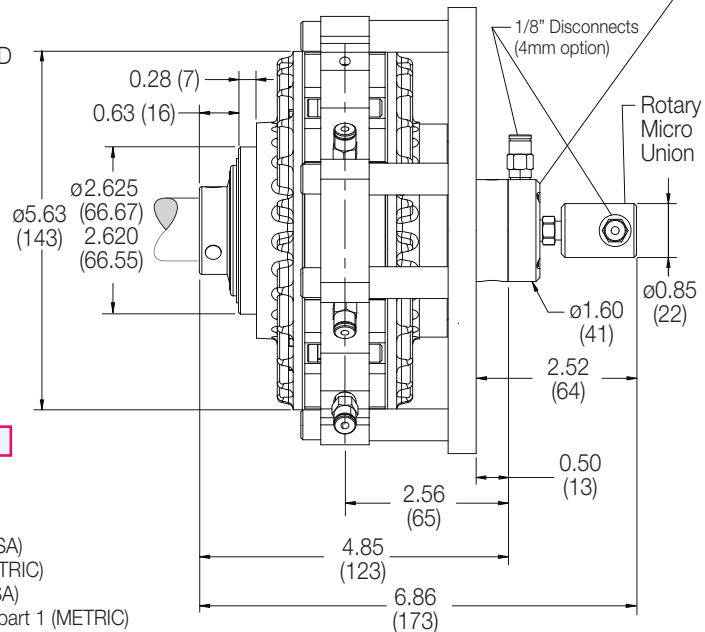

CD130

(CD136 shown)

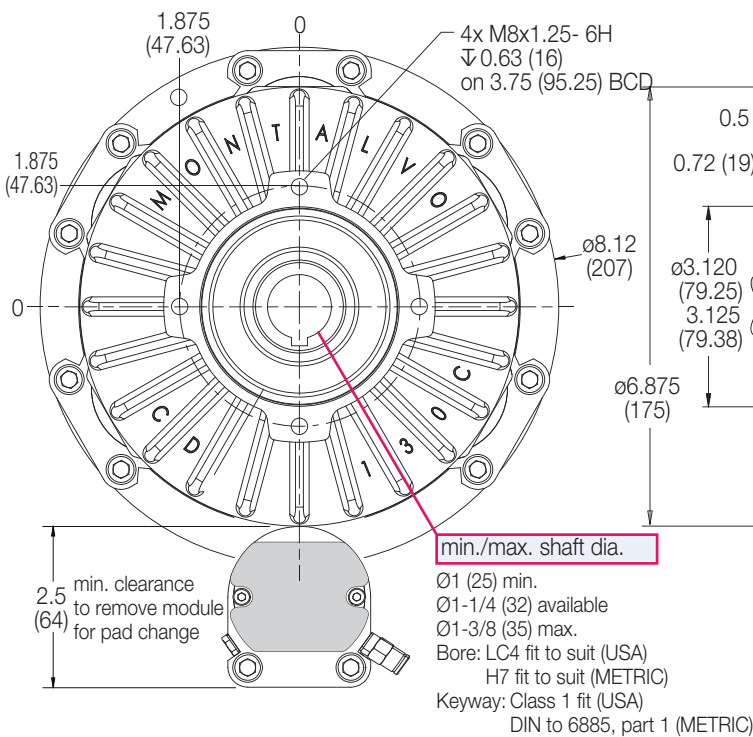
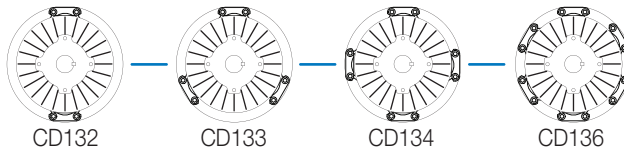

Air Transfer Cap Option (when ATC is used, drilling & tapping the shaft is not required)

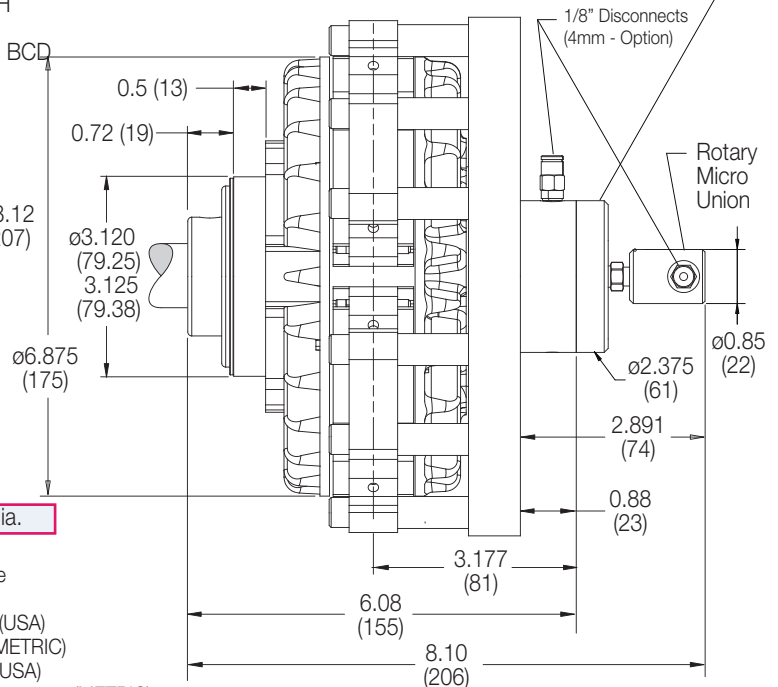

Shaft Preparation

For Montalvo Micro Rotary Union (MRU) Option

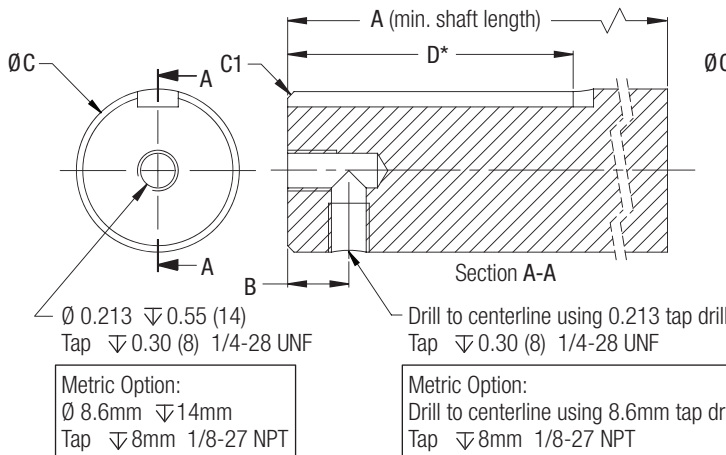

For Montalvo Air Transfer Cap (ATC) Option (no drilling/tapping required)

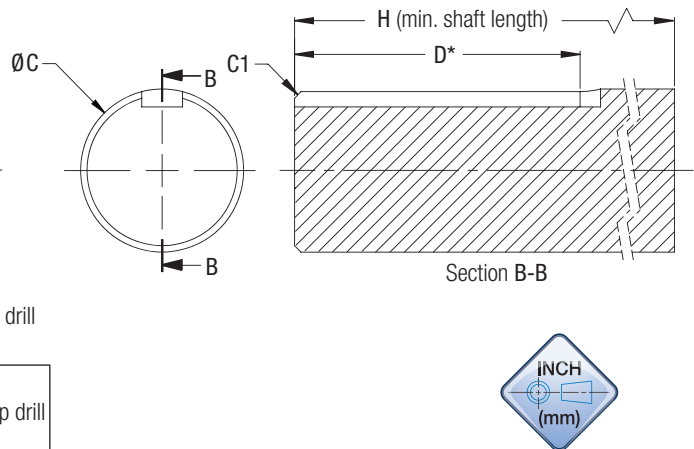

Size	A	B	C	C1	D*	H
CD100	5.08 (147)	0.250 (6.4)	LC4 fit (USA) and H7 fit to suit (METRIC) Engineering prints available upon request.	0.04 x 45° (1 x 45°)	1.50 (38)	4.85 (123)
CD130	6.30 (160)	0.375 (9.6)		0.04 x 45° (1 x 45°)	1.75 (45)	6.08 (155)

* Keyway: Class 1 fit (USA) DIN to 6885, part 1 (METRIC)

Friction Module

Add or replace a module

- Friction module kit*** Part #
- CD100 clutch 10001844
 - CD100 clutch (w/metric air fittings & tubing) 10002371
 - CD130 clutch 10001846
 - CD130 clutch (w/metric air fittings & tubing) 10002372
- * Kit includes two standard 4512 pads (many other types available - call or visit website for more details).

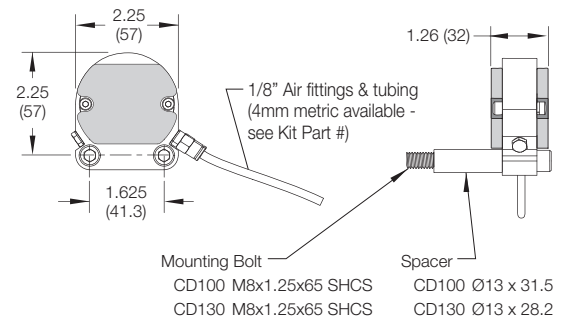
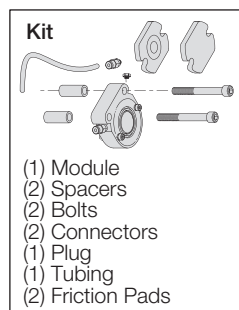

For a complete list of clutch and friction module replacement/spare parts contact Montalvo.

CD-Series

Compact Dual Disc Clutches

Torque[†]

	Max. - Min. (in-lb) (Max. @ 75 psi) - (Min. @ 1 psi)					
	LOW Friction		MEDIUM Friction		HIGH Friction	
CD100						
CD102	66	0.88	200	2.66	300	4.00
CD103	100	1.32	300	3.99	450	6.00
CD104	132	1.76	400	5.32	600	8.00
CD130						
CD132	88	1.16	266	3.40	400	5.20
CD133	132	1.74	400	5.10	600	7.80
CD134	176	2.32	533	6.80	800	10.4
CD136	264	3.48	798	10.2	1200	15.6

† Friction values are nominal. Rated torque may vary depending on operating temperature.

Effective Cooling Speed^{*}

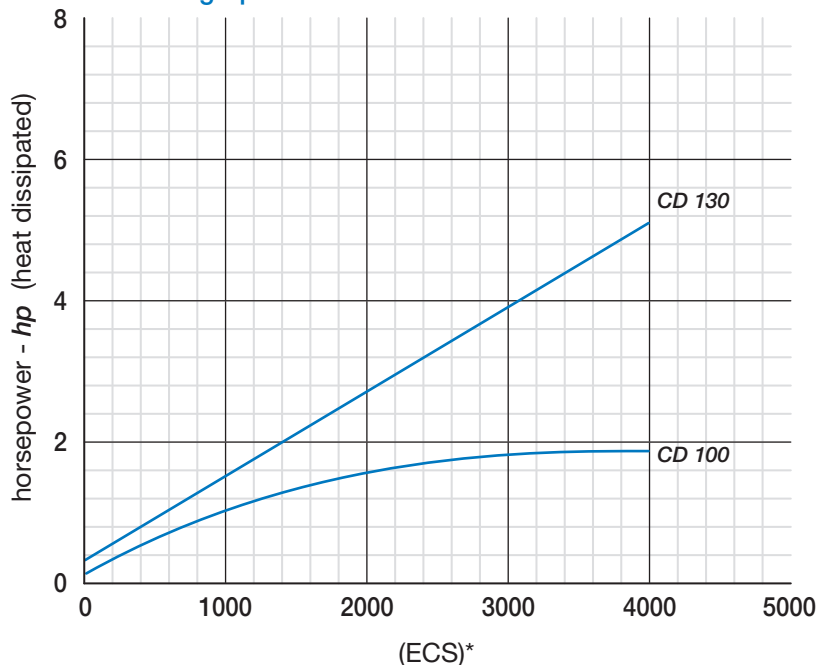

*Effective Cooling Speed (ECS)

The speed at which a clutch will dissipate a given heat horsepower.

$$ECS = \frac{2 (rpm \min.) + rpm \max.}{3}$$

Testing

The clutches were mounted as recommended in the Clutch Installation Instruction Manual. No guard or cover was used. Addition of machine guarding, fan or blower cooling, differences in ambient conditions, location, mounting method, etc. will affect heat (hp) dissipation capacity of any air cooled clutch. Careful consideration should be given to all conditions surrounding installation. Contact Montalvo for help in application sizing.

Conditions:

Ambient Temp.....55 - 60°F (13 - 16°C)
 Cast Iron Bulk350°F (177°C)
 (humidity) 65 - 70%

Size	Max. Speed* rpm	Inertia (Wr ²) (disc-hub) lb/ft ²	Weight (disc-hub) lb
CD100	7000	0.31	6.5
CD130	5500	0.58	10

* Do not use to calculate horsepower.

Note

Montalvo Clutches are called upon to operate within a wide speed range when used in converting applications They do not carry "nominal" ratings.

Related Montalvo Products

Rewind Tension Controllers

Electro-Magnetic Converters

Rotary Unions

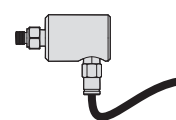
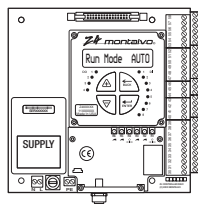

	207-856-2501 / 800-226-8710
	+86-21-52188010
	+45 75 57 27 11
	+49 (0)511 760 691 41

The Montalvo Corporation

EST. 1947

montalvo

Better Web Control®

50 Hutcherson Drive, Gorham, Maine 04038 USA
 Fax: 1-800-644-5097 / 207-856-2509

1-800-226-8710 / info@montalvo.com / www.montalvo.com

Technical details subject to change without notice. CDCLUTCH-US-10 © Montalvo