

All pixels, no sub pixels Time Domain Imaging™ SXGA-R3

Remote single/dual head microdisplay drive board

Forth Dimension Display's SXGA-R3 system is a fast switching, all digital, high-performance reflective microdisplay and interface electronics. Using no colour sub-pixels, the proprietary Time Domain Imaging technology provides full colour high resolution images from one all digital microdisplay.

The high frame rate of the SXGA-R3 enhances performance for producers of both display and non-display applications, such as spatial light modulation. This is a simple and instant plug and play unit that supports remote connection of either one microdisplay driven from one interface board (single channel system) or two microdisplays driven from one interface board plus daughter-board (dual channel system).

BENEFITS

High resolution

Full colour and all digital

No sub-pixels or colour filters

Compatible with multiple illumination sources

FEATURES

SXGA resolution (1280 x 1024 pixels)

Reflective microdisplay with 0.88" / 22.4mm diagonal

24-bit native colour depth (8-bit per colour)

Optional dither algorithms to increase greyscale resolution

Fast switching liquid crystal (typical 40 μ s)

Refresh rate up to 85Hz at full colour depth

Analogue (VGA) and Digital Video (DVI) inputs

96% fill factor

Remote connection of microdisplay(s) via LVDS connection

Optional dual head configuration

Different display addressing sequences available for diverse applications

USB 2.0/RS-232 interface for system control



APPLICATIONS

TRAINING AND SIMULATION

Monocular viewers

Biocular viewers

Head Mounted Displays (HMDs)

MEDICAL IMAGING

Image injection for surgical microscopes

Stereoscopic imaging

Ophthalmic metrology



A subsidiary of Kopin Corporation

All pixels, no sub pixels
Time Domain Imaging™

SXGA-R3

Remote single/dual head microdisplay drive board

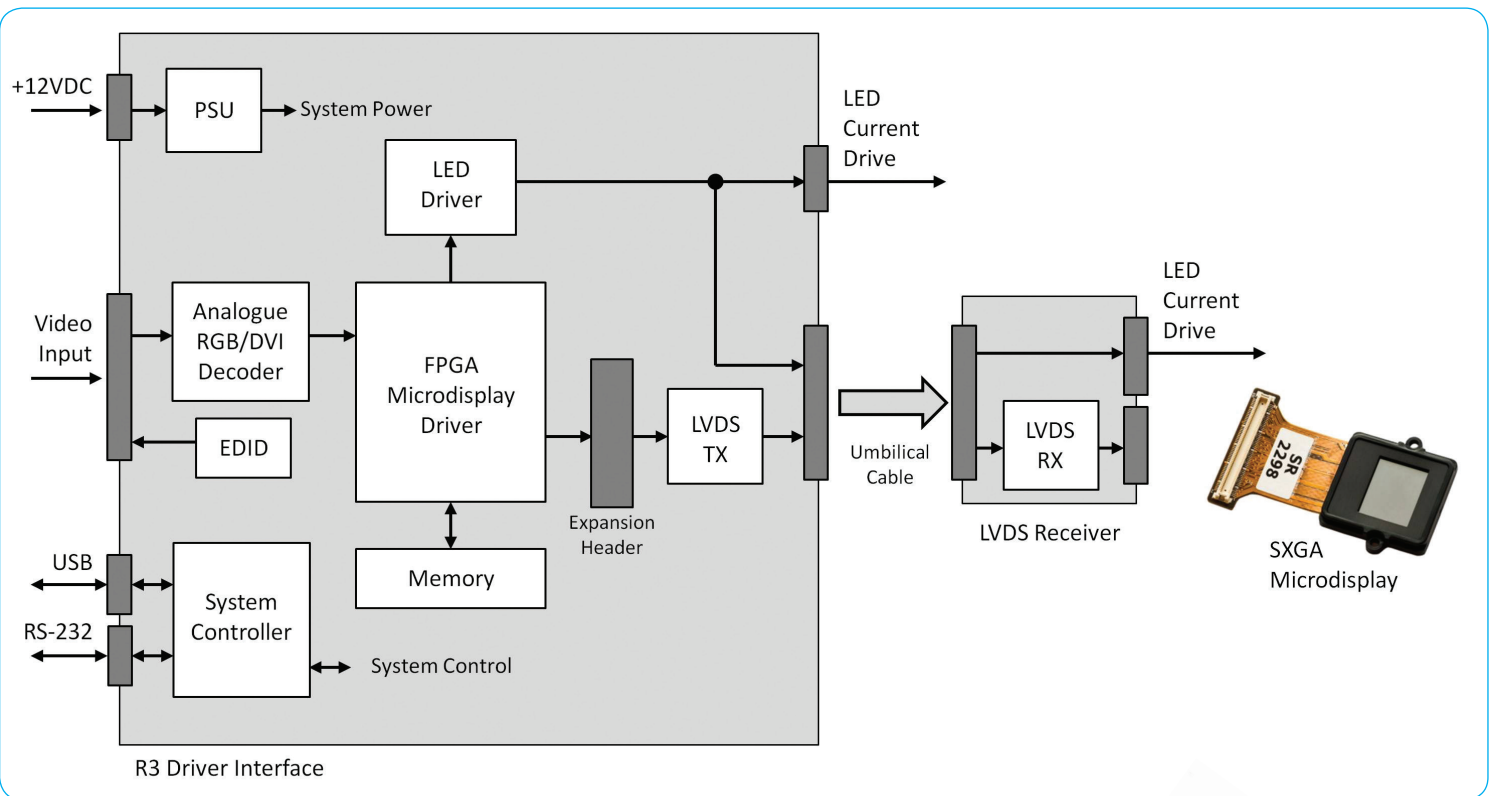

System Specifications

Resolution	SXGA (1280 x 1024 pixel)
Maximum Refresh Rate	85Hz (SXGA, 24-bit colour)
Interfaces	Analogue RGB + Syncs / DVI / USB 2.0 / RS-232
Synchronisation Outputs	LED Current Drive / LED Enables
Power	+12VDC / 14.4W (Single channel system)
Max Umbilical Cable Length	2.5m
Operational Temp Range	-10°C to +50°C



For further information or to
receive a quotation please contact:

T: +44(0)1383 827950 F: +44(0)1383 827951

E: sales@forthdd.com W: www.forthdd.com



A subsidiary of Kopin Corporation