

T2700 Power Relay

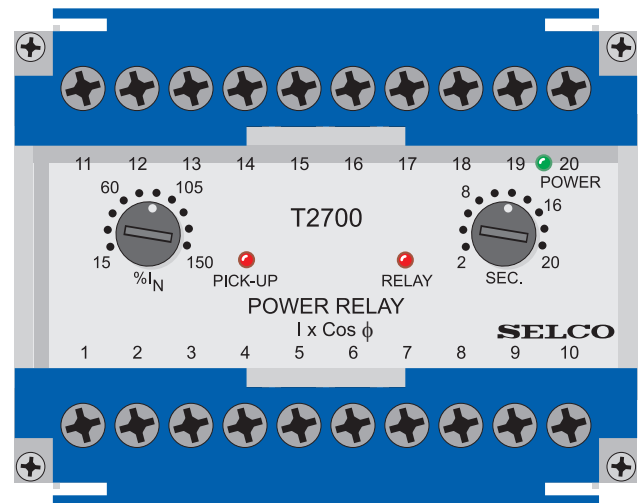

- Protection of generators against excessive active loads
- Visual indication of power, pick-up and relay tripping
- High precision digital countdown timer for delayed output
- Direct Line-Line supply where neutral is not available
- Accepts high supply voltage variations: 60 - 110%
- Cost effective and highly reliable compact design
- 50 hours burn-in before final test
- Certified by major marine classification societies
- Flame retardant enclosure



Application

The T2700 Power Relay is intended for detection of power levels for protection, control or monitoring purposes. The T2700 will protect a generator from excessive active loads.

Together with the T2000 Reverse Power Relay, the T2100 Excitation Loss Relay and the T2500 Overcurrent and Short Circuit Relay, the T2700 provides the optimal solution for complete generator protection, both in marine and land-based applications. The T2700 is type approved by major marine classification societies.

Function

The T2700 measures the voltage across phases L1 and L2 (or between L1 and neutral for L-N operation) and the current through a current transducer attached on phase L1.

The T2700 calculates $I \times \cos \phi$, representing the active power. If the active power exceeds the preset level (15 - 150%), the pick-up LED will indicate and the delay timer will be started.

After the preset time (2 - 20 sec.) has expired, the output relay and LED will be activated, provided that the active power level was exceeded for the entire delay time.

The output relay is a latching relay. The latching can be reset or disabled by bridging terminals 13 and 14.

Installation

Example of setting:

Required trip level: 90%
 Generator rating: 714A at PF = 0.8
 $I_p \text{ max: } 714 \times 0.8 = 571\text{A}$
 Current transformer: 800/5A
 Setting: $90 \times 571 / 800 = 64.2\%$

It is important that the phase where the current is measured always is connected to terminals 1 or 2. See connection diagram. For L-L operation terminal 3 is connected to the next phase in the phase sequence. For L-N operation terminal 3 is connected to neutral. For L-L operation terminal 3 is connected to the next phase in the phase sequence. For L-N operation terminal 3 is connected to neutral.

It is important that the phase sequence is correct and the current transformer side nearest the generators side is connected to terminal 5.

The LED based pick-up indication is ideal for testing. The T2700 can be tested by increasing the load on the generator, until the pick-up LED indicates exceeding the preset power level.

Troubleshooting

- 1) If the relay operates on reverse load, the terminals 5 and 6 are exchanged.
- 2) If the relay is not operating in any power direction and there is voltage on terminals 1 and 3 or terminals 2 and 3, check that current is floating in the current circuit terminals 5 and 6.
- 3) If the relay operates on different levels when the test is repeated, check that the voltage and current inputs have the correct phase relationship and that the phase sequence is correct.

Specifications

T2700 Power Relay

Trip level	15 - 150% I_N
Delay	2 - 20 sec.
Max. voltage	660V
Voltage range	60 - 110%
Consumption	Voltage 5VA at U_N Current 0.3VA at I_N
Continuous current	$2 \times I_N$
Frequency range	45 - 400Hz
Output relay	Normally de-energized, latching, resetable
Contact rating	AC: 400V, 5A, 1250VA DC: 150V, 5A, 120W
Overall accuracy	$\pm 5\%$
Repeatability	$\pm 1\%$
Operating temperature	-20°C to +70°C
Dielectric test	2500V, 50Hz
EMC	According to IEC/EN 61000-6-1/2/3/4
Approvals	Certified by major marine classification societies
Burn-in	50 hours before final test
Enclosure material	Polycarbonate. Flame retardant
Weight	0.5kg
Dimensions	70 x 100 x 115mm (H x W x D)
Installation	35mm DIN rail or 4mm (3/16") screws

The specifications are subject to change without notice.

Type Selection Table

Standard types: $I_N = 5A$

Type	Terminals		I_N	Supply	Function
	1-3	2-3			
T2700-00	230V		5A	L-N	
T2700-02	450V	400V	5A	L-L	
T2700-03	230V		5A	L-L	
T2700-04	110V	100V	5A	L-L	Normally energized output
T2700-08	127V	120V	5A	L-N	

Other supply voltages and combinations are available on request.

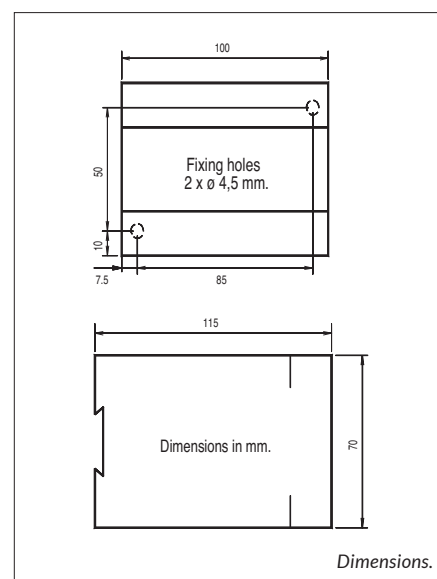
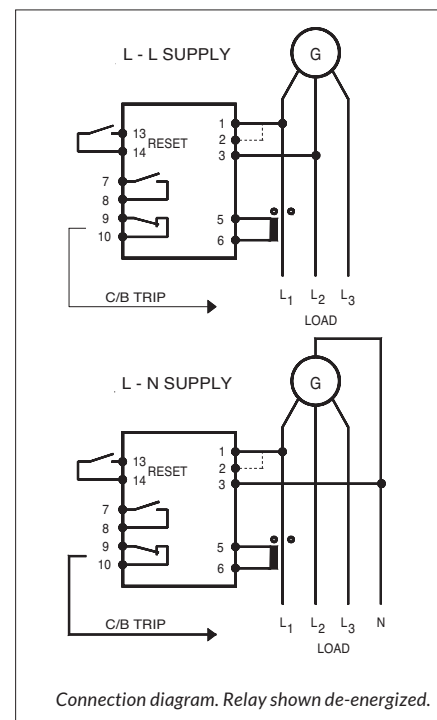

Approvals & Certificates

The T2700 has been approved by major marine classification societies.

For more information about the individual certificates, please visit selco.com