

D40 LIQUID LEVEL SWITCH

HEAVY DUTY TOP ENTRY SINGLE POINT LEVEL REGULATOR

FEATURES

- 5 to 500V AC 15A 1.5kW (2HP) Switch
- Gold Contact Low Wetting Current model available
- No metal parts in contact with liquids
- 60mm level change on to off or off to on
- Highly reliable magnetic action
- Fully sealed IP67 electrical housing
- M20 cable gland built in

APPLICATION

- Confined locations in sumps and pits
- Bund area warning alarms
- Cooling tower water level control
- Bilge water level alarm for boats
- Suits effluent & high solids uses
- Suitable for sea water & chemicals
- Level monitoring in wells & bores

OPERATING PRINCIPLE

The D40 level switch operates on Archimedes principle. When the non floating Polypropylene displacer suspended from the switch is immersed in liquid its weight is reduced by an amount equal to the weight of the liquid it displaces. This weight change is detected by a magnet and is used to actuate a powerful switch inside the electrical head of the D40. The D40 is designed to be used in water with a specific gravity of 0.95 or greater.

CONSTRUCTION AND OPERATION

The D40 level switch is constructed from solid billet aluminium. The displacer supplied with the switch is made from Polypropylene. The displacer is suspended from the underside of the D40 with chemically resistant Polypropylene cord (supplied). The D40 is supplied with two mounting brackets suitable for direct mounting on walls, tank lids or horizontal beams. The D40 level switch has no metal parts that come in contact with liquid regardless of the mounting method used. The actuating arm of the D40 operates the switch magnetically through the solid metal wall of the electrical housing.



ORDERING

D40 - □

DISPLACEMENT LEVEL SWITCH MODEL 40 BLANK = STANDARD SWITCH
L = LOW VOLTAGE SWITCH WITH GOLD CONTACTS

TECHNICAL DATA

DIMENSIONS

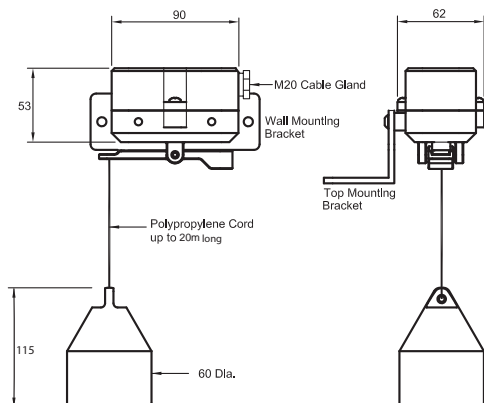

LIMITATIONS

Fixed switching differential	40mm +/- 5mm
Maximum distance between D40 & displacer	20 metres (3m of cord is supplied as standard)
Minimum distance from displacer to the floor of a tank or sump	20mm
Minimum inside diameter of pipe housing or shroud	65mm
Maximum liquid temperature	90°C
Specific gravity of process liquid	0.95 or greater
Ingress protection rating (weatherproof rating)	IP56 & IP68 to 1 meter submergence.

TYPICAL APPLICATION

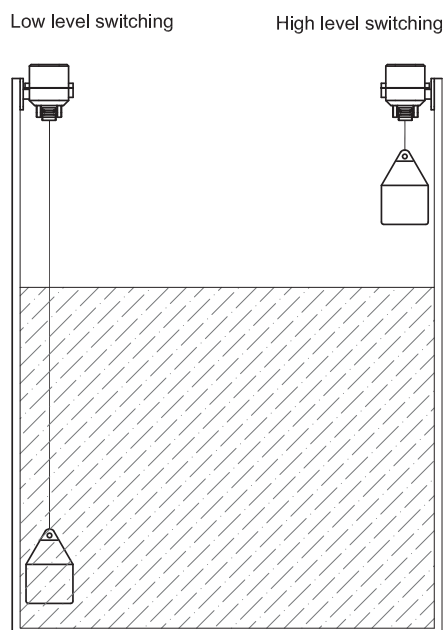

ELECTRICAL DATA FOR THE STANDARD D40

The standard D40 level switch houses a S.P.D.T (Single Pole Double Throw) switch. The standard switch is suitable for all general control circuit applications up to 500V AC. It is ideal for the control of pump starters, relay logic circuits, and for the direct control of contactors and timers. **The standard switch can operate at ANY voltage from 5 to 500VAC. It is rated to directly control motors up to 1.5kW (2HP) at 240VAC.**

RATED VOLTAGE	NON INDUCTIVE LOADS				INDUCTIVE LOADS			
	RESISTIVE LOAD		LAMP LOAD		INDUCTIVE LOAD		MOTOR LOAD	
	NO	NC	NO	NC	NO	NC	NO	NC
125 VAC	20 A		7.5 A		20 A		12.5 A	
250 VAC	20 A		7.5 A		20 A		8.3 A	
500 VAC	15 A		4 A		10 A		2 A	
8 VDC	20 A		3 A	1.5 A	20 A		12.5 A	
14 VDC	20 A		3 A	1.5 A	15 A		12.5 A	
30 VDC	6 A		3 A	1.5 A	5 A		5 A	
125 VDC	0.5 A		0.5 A		0.05 A		0.05 A	
250 VDC	0.25 A		0.25 A		0.03 A		0.05 A	

ELECTRICAL DATA FOR LOW VOLTAGE D40-L

The D40-L level switch houses a S.P.D.T. low voltage low wetting current switch with gold contacts it is suitable for Ex and signalling applications.

Maximum Switched Voltage	30VDC
Maximum Switched Current	26mA
Minimum Switched Voltage	5VDC
Minimum Switched Current	1mA

Note: Do not apply loads in excess of the limits in the table above. Do not apply inductive or capacitive loads to the L microswitch. The "L" microswitch will be damaged by loads in excess of the limits in the table above.

Maximum Switched Voltage	500VAC
Maximum Switched Current	15A
Minimum Switched Voltage	5VDC
Minimum Switched Current	160mA

Note: Do not apply maximum voltage at maximum current across the switch contacts. See main data table for current limits at specific voltages and for specific loads.

HAZARDOUS APPLICATIONS

The D40-L Level switch switch can be used in hazardous areas. The switch is classed as a simple device and does not contain components capable of storing or producing an electric charge. As a simple device the D40-L can be used in hazardous applications provided it is isolated by an intrinsically safe barrier, a zener barrier.

KELCO Engineering Pty Ltd

ABN 20 002 834 844 Head office and factory: 9/9 Powells Road Brookvale NSW 2100 Australia. Postal Address: PO Box 7485 Warringah Mall Post Shop Brookvale NSW 2100 Australia. Phone: +61 2 9905 6425 Fax: +61 2 9905 6420 Email: Sales@kelco.com.au Web: www.Kelco.com.au

PLEASE NOTE: Kelco Engineering Pty Ltd reserves the right to change the specification of this product without notice. Kelco Engineering Pty Ltd accepts no liability for personal injury or economic loss as a consequence of the use of this product. All rights reserved copyright Kelco Engineering Pty Ltd © 2018 This Kelco product is protected by a 12 month return to base warranty. Full details of our warranty can be downloaded from: <http://www.kelco.com.au/warranty>