

Surface Strain Transmitter

for indirect measurement of process forces

Type 9238B...

Patent No. US 7,694,577 B2

This transmitter with an integral fully-digital charge amplifier is particularly suitable for measuring dynamic and quasistatic forces on stationary or moving machine parts. The transmitter uses indirect force measurement to sense the force-proportional strain on machinery or structural surfaces.

- Easy user-friendly parameter configuration via integral serial interface using ManuWare PC program
- Two fully programmable independent measuring ranges (adjustable between $\pm 20 \mu\epsilon$ and $\pm 800 \mu\epsilon$), switchable under load
- Adjustable FSO voltage ($\pm 1 \dots 10 \text{ V}$), offset voltage ($\pm 9 \text{ V}$) and output signal polarity
- Low-resistance voltage output from integral charge amplifier
- Extremely easy mounting and IP67 protection for industrial use

Description

The strain of the basic material acts via the two contact surfaces on the sensor as a change in distance. The sensor housing behaves as an elastic transmission element that converts the change in distance into a force. The sensor's piezoelectric elements in shear generate an electric charge Q [pC] proportional to this force. The strain transmitter's integral electronics then convert this charge into an analog voltage signal.

The particular advantages of piezotechnology compared with the familiar foil strain gage technology are high sensitivity, high overload resistance, virtually unlimited service life and high load cycle stability.

The measurement signal can be processed as a relative value. For absolute value measurements (e.g. in N or kN) the strain sensor must be calibrated against an appropriate reference.

Excitation voltage and measuring cycle control, range switching and communications interface data are carried to the transmitter via the same cable used to transmit the measurement signal.



The amplifier parameters are configured entirely via the integral serial interface using the included ManuWare PC program. For test purposes it is also possible to transmit digital measurement data (at a rate $< 20 \text{ Hz}$) and display it on the screen using ManuWare.

The industrial design is rated at IP67 and careful fabrication of the sensor allow use in dirty and wet environments.

Applications

The strain sensor Type 9238B... can be used for monitoring all types of machinery with a gap frame, such as mechanical presses and automatic assembly machines. Its ease of mounting makes it ideal for retrofitting to existing machinery. Specific applications include:

- Machine monitoring, such as protecting mechanical presses against overload
- Quality assurance in production runs for joining processes such as wobble riveting, clinching and resistance spot welding
- Monitoring machine tools, such as prompt detection of tool breakage or tool collision

Technical data

Measuring ranges, preset

Measuring range I	$\mu\epsilon$	-500 ... 500
Measuring range II	$\mu\epsilon$	-50 ... 50
Calibrated measuring range	$\mu\epsilon$	0 ... 500/0 ... 50
Sensitivity (at 10 V FSO)		
Measuring range I/II	mV/ $\mu\epsilon$	20/200
Linearity	% FSO	$\leq \pm 2$
Mechanical overload ¹⁾	$\mu\epsilon$	$\pm 1\ 000$

Measuring ranges, fully programmable

Programmable measuring range I/II ²⁾		
from	$\mu\epsilon$	-20 ... 20
to	$\mu\epsilon$	-800 ... 800
Programmable output voltage ²⁾		
from	V	-1 ... 1
to	V	-10 ... 10
Resultant sensitivity	mV/ $\mu\epsilon$	$\pm 1,25$... 500
Adjustment error	% FS	<0,5

Output

Output voltage limit	V	$\pm 10,5$
Maximum output current	mA	± 1
Output resistance	Ω	≈ 10

Amplifier characteristics

Zero error (in reset condition)	mV	$< \pm 15$
Noise (0,1 ... 1 MHz)	mV _{pp}	<30
Measure jump	mV	$< \pm 25$
Frequency range (-3 dB)	kHz	≈ 0 ... 1
Drift at 20 °C (at FSO)	mV/s	$< \pm 2$
Polarity switching ²⁾		yes
Offset voltage ²⁾	V	± 9
Maximum resolution	mV	± 5

Control signals

Control voltage	VDC	3,2 ... 30
Current consumption	mA	$< \pm 1$
Reset/Measure switching (pin 3)		
Reset	V	3,2... 30 (or disconnected)
Measure	V	0 ... 0,6
Delay	ms	<10
Measuring range switching (pin 5)		
Measuring range I	V	3,2 ... 30 (or disconnected)
Measuring range II	V	0 ... 0,6
Delay	ms	<2

RS-232C serial interface

EIA standard		RS-232C
Baud rate	bps	115 200
Data bits		8
Stop bit		1
Parity		none
Software handshake		no
Max. cable length	m	5

General technical data

Excitation voltage	VDC	18 ... 30
Current (no load)	mA	<70
Operating temperature range	°C	-10 ... 70
Storage temperature range	°C	-20 ... 80
Weight (without cable)	g	190
Protection rating (DIN40050) ³⁾	-	IP67
Connector ⁴⁾	-	M12x1 8-way, shielded

- 1) The strain transmitter is not irreparably damaged by an overload, but does have to be remounted and re-calibrated.
- 2) Adjustable via RS-232C
- 3) With cable connected
- 4) Compatible with LUMBERG, Escha, Binder, Hirschmann and Lemo connectors and cables

The transmitter conforms to EMC standards EN61000-6-3 (emission) and EN61000-6-2 (immunity).

Dimensions

Strain transmitter with connecting cable Types 1787A... and 1789A...

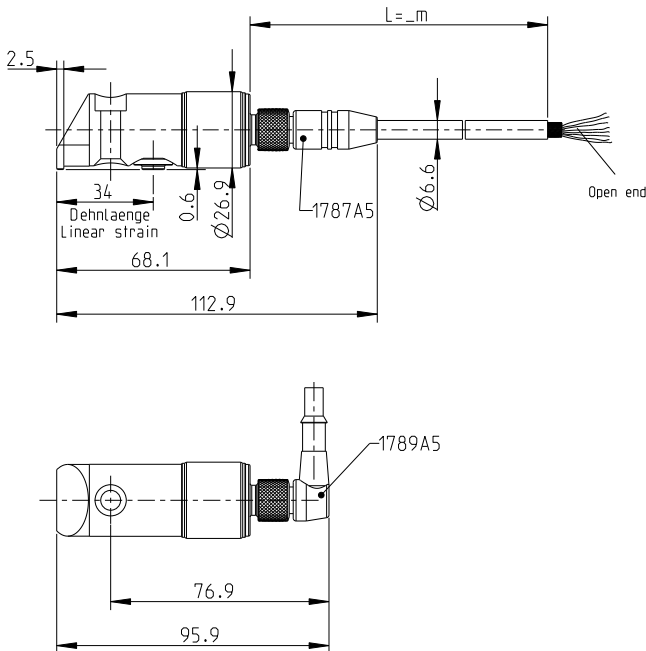

Fig. 1: Dimensions of Type 9238B...

Pin allocation

Pin allocation for strain transmitter with connecting cable Type 1787A... or 1789A...

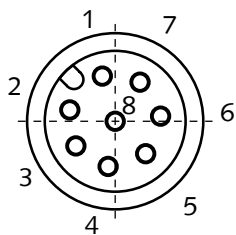

Fig. 2: Pin allocation

Colors of individual conductors of 8-way connecting cable Type 1787A... and 1789A... (Ref.: LUMBERG Germany)

Pin	Signal	Core color
1	Exct GND	white
2	Signal GND	brown
3	/ Measure	green
4	Signal Out	yellow
5	/ Range II	grey
6	RS-232C_Rx	pink
7	RS-232C_Tx	blue
8	+Exct	red

Mounting

- Machine the surface at the measuring point (N7; Ra 1,6 microns) and tap the M6 female thread (see Fig. 3).
- Align the sensor relative to the structure of the machine. Position the measuring axis to record the maximum strain curve (Fig. 4).
- Secure the transmitter with a single screw with pre-greased thread and head bearing surface. Preload the screw to a torque of 14 N·m (Fig. 5)
- The cable run close to the transmitter should be as free from tension or compression forces as possible. Transmission of cable movements or vibration to the sensor must be avoided.

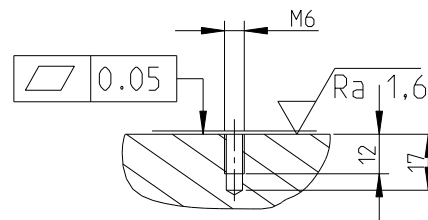

Fig. 3: Preparing the mounting surface

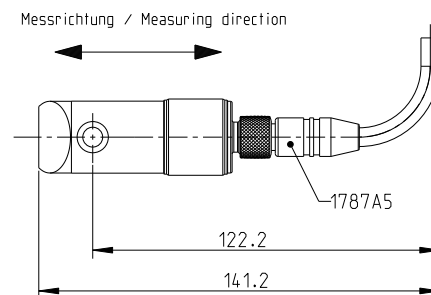

Fig. 4: Aligning sensor to the maximum strain axis

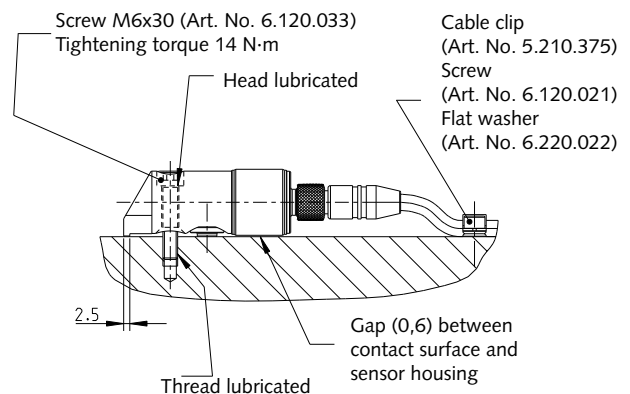

Fig. 5: Mounting with 6-point socket head cap screw

Configuring charge amplifier

The transmitter's parameters are configured entirely via the integral serial interface (RS-232C) using the ManuWare PC program on the included CD (see Fig. 7). This program's user-friendly interface allows easy and convenient configuration of the transmitter to suit the current measurement requirements. For test purposes it is also possible to transmit digital measurement data (at a rate <20 Hz) and display it graphically with the software.

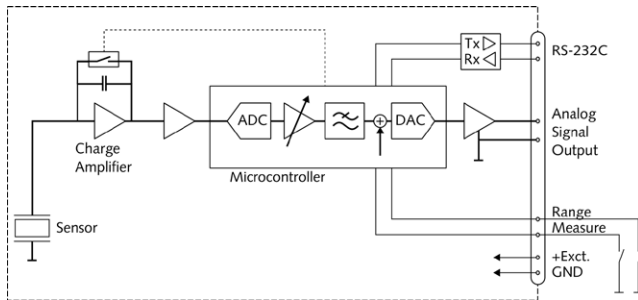

Fig. 6: Block circuit diagram

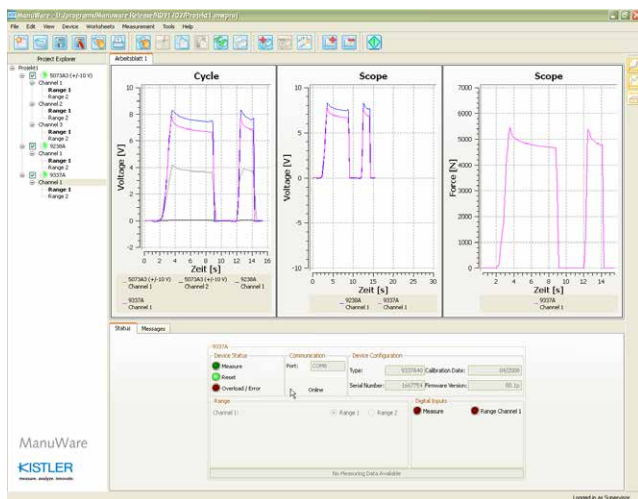

Fig. 7: ManuWare interface for parameter configuration and test measurements

Configuration examples

Example 1

Input signal of $-300 \dots 300 \mu\epsilon$ with positive output signal of $0 \dots 10 \text{ V}$

- Measuring range of input signal set to $300 \mu\epsilon$
- FSO set to 5 V
- Offset voltage set to 5 V
- Polarity of output signal not inverted

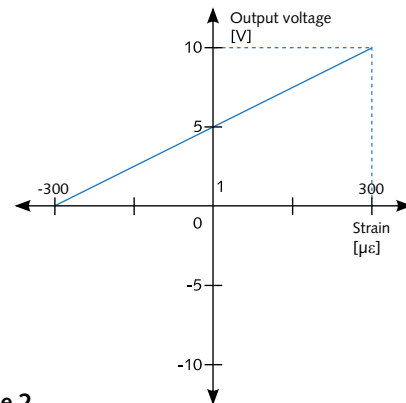

Example 2

Input signal of $0 \dots -60 \mu\epsilon$ with life zero at 1 V and 8 V FSO

- Measuring range of input signal set to $60 \mu\epsilon$
- FSO set to 8 V
- Offset voltage set to 1 V
- Polarity of output signal inverted

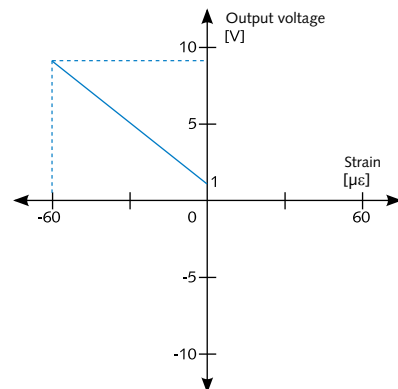

Example 3

Input signal of $500 \dots -500 \mu\epsilon$ with life zero at 1 V and 9 V FSO

- Measuring range of input signal set to $500 \mu\epsilon$
- FSO set to 9 V
- Offset voltage set to 1 V
- Polarity of output signal not inverted

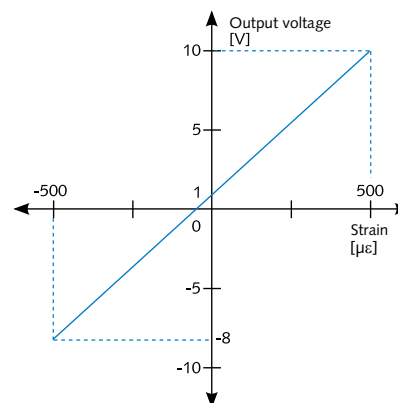

Typical applications



Fig. 8: Indirect force measurement on knuckle joint

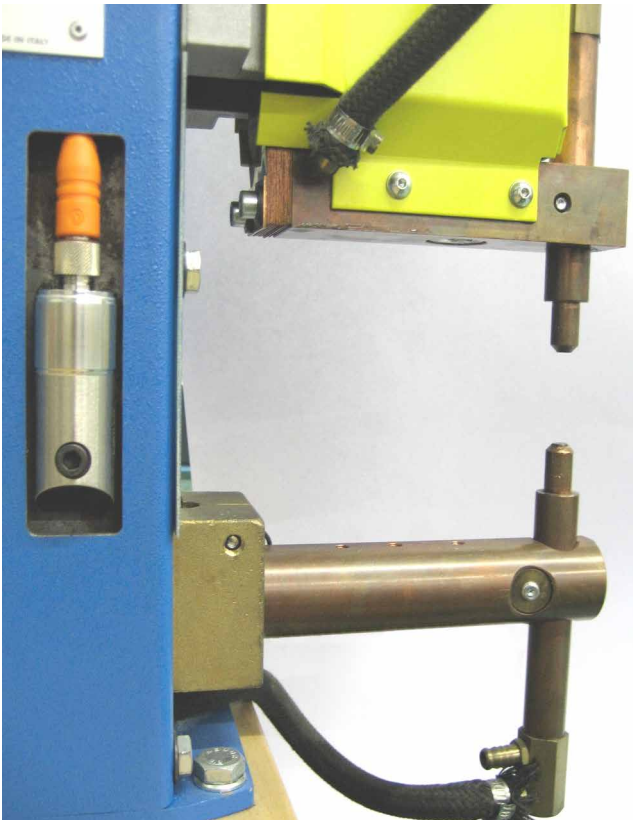

Fig. 9: Indirect electrode force measurement on spot welding machine

Included accessories

- Protective cap for connector
- Program CD with
 - ManuWare parameter configuration program,
 - Flash loader for firmware updates,
 - Firmware

Type/Art. No.

5.211.409

Mounting accessories

- 6-point socket head cap screw M6x30 (DIN 912)
- Special lubrication grease

6.120.033

1063

Optional accessories

Shielded cable connection to machine control system

- Connecting cable M12 8-pin neg. connector straight – unterminated, 5 m cable length
- Connecting cable M12 8-pin neg. angle connector right-angled – unterminated, 5 m cable length
- Intermediate service cable with RS-232C branch for programming the transmitter

Type

1787A5

1789A5

1787A-1

Ordering key

Type 9238B10

Measuring range

Standard calibration
(measuring range I = $\pm 500 \mu\epsilon$ / II = $\pm 50 \mu\epsilon$)

1

Custom calibration available on request