

# PROFILING SYSTEM USER MANUAL

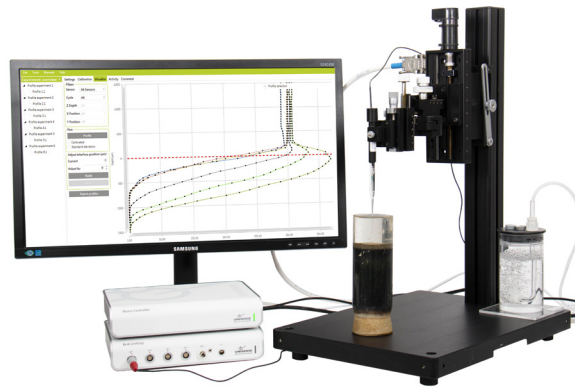

**PROFILING SYSTEM USER MANUAL**

Copyright © 2020 · Unisense A/S

Version December 2020

# **PROFILING SYSTEM USER MANUAL**

UNISENSE A/S



# TABLE OF CONTENTS

WARRANTY AND LIABILITY.....	6
CONGRATULATIONS WITH YOUR NEW PRODUCT!.....	7
SUPPORT, ORDERING, AND CONTACT INFORMATION	7
OVERVIEW.....	9
MICROSENSOR AMPLIFIERS.....	10
MANUAL MICROMANIPULATORS.....	11
SPECIFICATIONS (MM33 AND MM33-2)	11
MOTORIZED SYSTEMS.....	12
SPECIFICATIONS FOR CONTROLLER MOTCON	13
SPECIFICATIONS FOR STAGE MMS/MMS-30 (WITH MOTCON)	13
MICROMANIPULATOR STANDS.....	14
SPECIFICATIONS LABORATORY STAND LS:	14
SPECIFICATIONS IN SITU STAND IS19	14
SETTING UP.....	15
ASSEMBLY PROCEDURE 1D MOTORIZED SYSTEM.....	17
ASSEMBLY PROCEDURE 2D MOTORIZED SYSTEM.....	19
ASSEMBLY PROCEDURE 3D MOTORIZED SYSTEM.....	21
STORAGE AND MAINTENANCE.....	25

# WARRANTY AND LIABILITY

## NOTICE TO PURCHASER

This product is for research use only. Not for use in human diagnostic or therapeutic procedures.

## WARNING

Microsensors have very pointed tips and must be handled with care to avoid personal injury and only by trained personnel. Unisense A/S recommends users to attend instruction courses to ensure proper use of the products.

## WARRANTY AND LIABILITY

The MicroProfiling System is covered by a one year limited warranty.

The warranty does not include repair or replacement necessitated by accident, neglect, misuse, unauthorized repair, or modification of the product. In no event will Unisense A/S be liable for any direct, indirect, consequential or incidental damages, including lost profits, or for any claim by any third party, arising out of the use, the results of use, or the inability to use this product.

Unisense mechanical and electronic laboratory instruments must only be used under normal laboratory conditions in a dry and clean and environment. Unisense assumes no liability for damages on laboratory instruments due to unintended field use or exposure to dust, humidity or corrosive environments.

## REPAIR OR ADJUSTMENT

Sensors and electrodes cannot be repaired. Equipment that is not covered by the warranty will, if possible, be repaired by Unisense A/S with appropriate charges paid by the customer. In case of return of equipment please contact us for return authorization.

For further information please see the documents Conditions for Sale and Delivery for Unisense and Warranty and Shipping Information as well as the manuals for the respective products.

# CONGRATULATIONS WITH YOUR NEW PRODUCT!

## **SUPPORT, ORDERING, AND CONTACT INFORMATION**

If you wish to order additional products or if you encounter any problems and need scientific/technical assistance, please do not hesitate to contact our sales and support team. We will respond to your inquiry within one working day.

E-mail: [sales@unisense.com](mailto:sales@unisense.com)

Unisense A/S  
Tueager 1  
DK-8200 Aarhus N, Denmark  
Tel: +45 8944 9500  
Fax: +45 8944 9549

Further documentation and support is available at our website [www.unisense.com](http://www.unisense.com).

## **REPLACEMENT OF SENSORS**

*Unisense will replace sensors that have been damaged during shipment provided that:*

- *The sensors were tested immediately upon receipt in accordance with the delivery note and the manual*
- *The seal is still intact.*
- *The sensors are returned to Unisense for inspection within two weeks.*
- *The sensors are correctly packed for return to Unisense, in accordance with the note included in the sensor box.*





# OVERVIEW

With its stability, precision, and eminent spatial resolution, the MicroProfiling System is an outstanding tool for microscale measurements for a variety of applications.

The optimal choice of sensors and equipment depends on what kind of experiment you want to perform.

You can perform manual or automated profiles. In manual profiles, the micromanipulator is operated by hand. For increased accuracy and automatic profiles, a motorized stage and motor controller can be used. This will increase microsensor positioning precision, extend the travelling distance, facilitate multiple automated profiles and free the scientist from the tedious manual micromanipulator operation.

This manual gives an overview of the components of a Unisense profiling measurement set-up and how to connect them. For details on each component, please consult the individual manuals.

# MICROSENSOR AMPLIFIERS

It takes a specialized high-quality amplifier to amplify the signal from a microsensor.

Amperometric microsensors (e.g.  $O_2$ ,  $H_2S$ ,  $H_2$ ) require either a versatile amplifier with adjustable polarization like the MultiChannel UniAmp fx-6 or fx-3 or a picoammeter with preset polarization like the  $O_2$  UniAmp.

Potentiometric microsensors (e.g. pH and Redox) require a high-impedance millivoltmeter like the pH/Redox UniAmp or a MultiChannel UniAmp.

All Unisense amplifiers have an integrated A/D-converter unit, so they are connected to the computer directly.

Please see separate manuals for more detailed instruction and specifications.



*MultiChannel UniAmp*



*SingleChannel UniAmp*

# MANUAL MICROMANIPULATORS

A microsensor must be positioned in the measuring environment with much more precision than is possible to achieve with an ordinary laboratory stand. Therefore, Unisense supplies manual micromanipulators with holders for one (MM33) or two sensors (MM33-2), which facilitate reliable measurements and minimize the risk of breaking the microsensor.

Mounted on a suitable laboratory stand (e.g. the Unisense LS), the micromanipulator provides a robust and precise tool for positioning microsensors with a x-axis precision of 10 microns. The y- and z-axis can be manipulated with a precision of 100 microns.

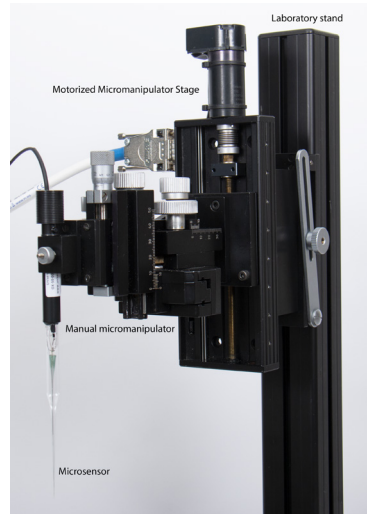

*Micromanipulator mounted on a Motorized Micromanipulator Stage*

The MM33-2 offers the possibility for simultaneous positioning of two sensors. It allows for extremely fine adjustment of the two microsensor tips relative to each other so that the two sensors measure practically at the same point.

## SPECIFICATIONS (MM33 AND MM33-2)

- Weight: 1100 g (MM33), 1240 g (MM33-2)
- z-axis: 37 mm, resolution 100  $\mu\text{m}$ 
  - 10 mm, resolution 10  $\mu\text{m}$
  - 100 mm, resolution 0.5  $\mu\text{m}$ , MMS
  - 300 mm, resolution 0.5  $\mu\text{m}$ , MMS-30
- y-axis: 20 mm, resolution 100 microns
- x-axis: 25 mm, resolution 100 microns

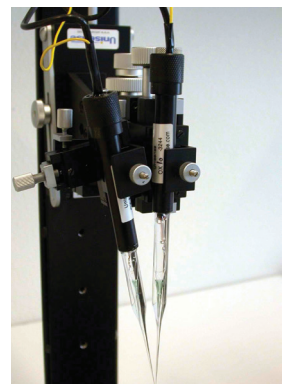

*Double micromanipulator mounted with sensors*

# MOTORIZED SYSTEMS

For precision below 10 micron in the x-axis and for automated measurements, the MM33 (or MM33-2) can be mounted on a motor-driven micromanipulator stage (MMS), which is positioned via the PC data acquisition and motor control software (SensorTrace Suite) and a motor controller (MOTCON). With multiple motors and motorcontrollers automated measurements can be performed in 2D or 3D with extreme precision in all directions.

Motorized sensor positioning is superior to manual positioning due to a higher level of precision, a longer operating distance, and ease of operation. A motorized unit consists of a micromanipulator (MM33/MM33-2) mounted on a motorized mechanical stage (MMS/MMS-30) via a small adapter. The stage is controlled by PC software (SensorTrace Suite) via a motor controller (MOTCON).

A manual positioning system can always be upgraded to a motorized system. This requires a Motor stage (MMS/MMS-30), an adaptor (MMS-A), and a motor controller (MOTCON).

## *Motor Controller*



## SPECIFICATIONS FOR CONTROLLER **MOTCON**

- AC power supply adaptor: In: 100-240 VAC, 60-50 Hz, 1.4 A Out: 24VDC, 5A, 120 W max
- Interface: RS232 (adapter cable for USB port provided)
- Configured for: Unisense MMS and MMS-30
- Operating temperature: 0-70°C (32 to 158°F)
- <90% RH non-condensing

## SPECIFICATIONS FOR STAGE **MMS/MMS-30 (WITH MOTCON)**

- Movement in longitudinal axis: 100 mm (MMS) or 300 mm (MMS-30)
- Resolution of motorized micromanipulator stage: 0.5  $\mu\text{m}$
- Accuracy: 0.2%
- Maximum linear speed: 20 mm/sec
- Minimum linear speed: 0.1  $\mu\text{/sec}$
- Maximum axial load: 5 kg (11 lbs)
- motor type: DC-brush

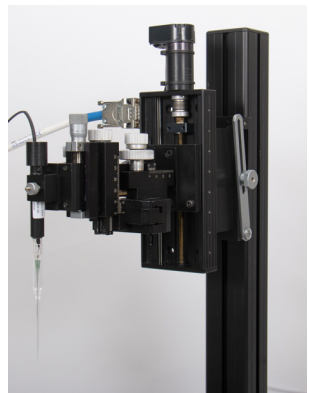

*Micromanipulator mounted on a stage*

# MICROMANIPULATOR STANDS

The LS is a highly stable, corrosion-protected laboratory stand, which makes it possible to maintain the precision of the MM33, MM33-2 and the motorized micromanipulator stage.

The in situ stand IS19 is a light-weight micromanipulator stand for field use in soft substrates such as mud or sediments. It consists of a pointed angular aluminum pole, and its tip is pushed into the substrate to provide a robust support for micromanipulators and sensors during in situ experiments. It can be used under water as well as in air.

## **SPECIFICATIONS LABORATORY STAND LS:**

- Weight: 12 kg (26.5 lbs)
- Dimensions: 40 cm x 30 cm x 54 cm (15.7" x 11.8" x 21.3") assembled.
- Surface treatment: anodized

## **SPECIFICATIONS IN SITU STAND IS19**

- Weight: 2.5 kg (5.5 lbs)
- Height: 70 cm (28")
- Fixation holes: thread M6, spacing between holes 5 cm (2")
- Surface treatment: anodized

# SETTING UP

The following section will describe a typical profiling set-up. Please consult separate manuals for the individual components for further details.

1. Install the Unisense SensorTrace Suite software.
2. Place the laboratory stand LS on a stable and smooth surface. Adjust the feet to prevent the stand from rocking. If the sample is not to be placed on the stand plate, the stand should be placed at an appropriate distance from the sample to allow space for the micromanipulator.
3. Mount the micromanipulator or assembled motorized system (see below for instructions) on the stand with the fixation screw at a suitable height so that the lower side of the sensor holder is positioned about 12.5 cm/5" above the top of the sample, when the microsensors z-axis is completely retracted.
4. If motorized, connect the motor port of the motor controller(s) to the motor stage(s) using the motor cable(s).
5. Connect the the motor controllers to the PC using the USB (USB - mini USB) cable. In the SensorTrace Profiling software setup screen each connected motor controller can be assigned to a specific axis. Clicking the controller on the setup screen will cause the green light on the motor controller to blink for identification. See the SensorTrace Suite User Manual for details.
6. Place the microsensors amplifier(s) near the stand (0.5m/1.5ft)
7. Connect the amplifiers to the PC using the USB cable.
8. Place the sample to be investigated under the micromanipulator
9. Place a microsensors in the holder of the micromanipulator with

the tip a few centimetres above the sample. Move the sensor horizontally to the desired location with the x- and y-controls. Be careful not to break the microsensors tip!

10. Make measurements with the sensors according to the manuals for the sensors and software.

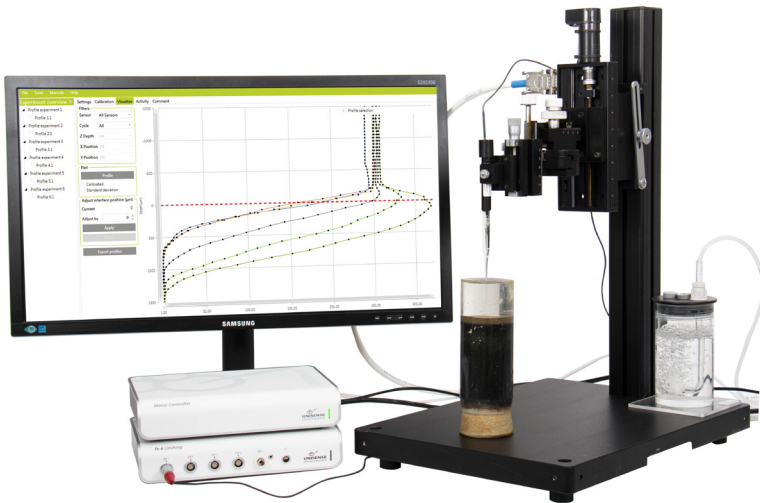

*Motorized 1D profiling set-up with fx-6 UniAmp, one motor controller, single sensor, CAL300 and computer (not provided)*



# ASSEMBLY PROCEDURE 1D MOTORIZED SYSTEM

1. Take the MM33 or MM33-2 and use the hexagonal (Allen) key to unmount the front part from the tilting base. Save the screws.

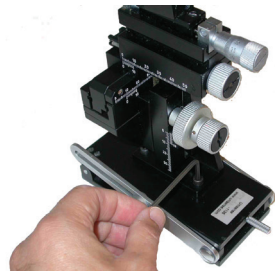

2. With 2 of the provided large screws, mount the U-profile on the tilting base.

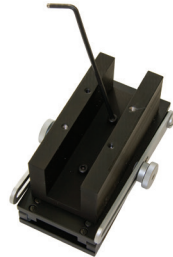

3. Mount the motorized stage MMS onto the U-profile: First, make sure that **the tilt of the micromanipulator base will go out in the opposite end of the motor** (see picture right) – this will decrease the risk of accidents with sensor damage. Move the stage plate completely down by turning the spindle joint with a finger and mount two of the provided large screws in the two upper of the four central holes in the back of the stage as shown below. Then turn the spindle to move the stage plate completely in the opposite direction to mount two of the provided large screws in the bottom holes.



4. The provided square plate (MMS-A) has four holes: two center holes near the middle and two corner holes near the corners. With the MMS motor unit pointing **away from you**, mount the plate with the two center holes located just right of the middle. Use the last two large screws
  
5. Mount the MM33 or MM33-2 on the plate using the two screws that you removed in step 1 above.
  
6. Mount the assembled motor stage and micromanipulator on the Laboratory stand with the large finger bolt through the central hole in the tilting base plate. Tighten the screw well using the supplied (metal rod, slightly bent at one end).

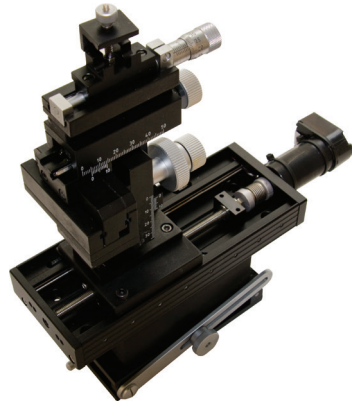

# ASSEMBLY PROCEDURE 2D MOTORIZED SYSTEM

1. Follow step 1 and 2 from the 1D assembly procedure.
2. Mount one motor stage **across** the U-profile (see picture). Move the stage plate completely down by turning the spindle joint with a finger and mount two of the provided large screws in the two upper of the four central holes in the back of the stage as shown below. Then turn the spindle to move the stage plate completely in the opposite direction and mount two of the provided large screws in the bottom holes.
3. Place the second motor stage on the first one. The second stage must be perpendicular to the first one. Orient the second stage so that the motor points in the direction where the tilting plate is hinged (see step 3 in the 1D assembly procedure above). Move the stage plate completely down by turning the spindle joint with a finger and mount two of the provided screws in the two upper of the four central holes in the back of the stage. Then turn the spindle to move the stage plate completely in the opposite direction to mount two of the provided screws in the bottom holes.

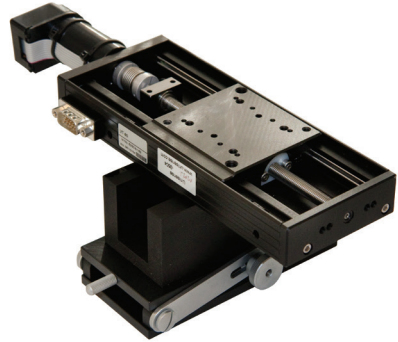

4. The provided square plate has four holes: two center holes near the middle and two corner holes near the corners. With the 1D MMS neck (controller connection) pointing **upwards**, mount the plate with the two center holes located just right of the middle. Use the large screws (see picture under 1D motor mounting)
5. Mount the MM33 or MM33-2 on the plate using the two screws from step 1 in the 1D assembly procedure.

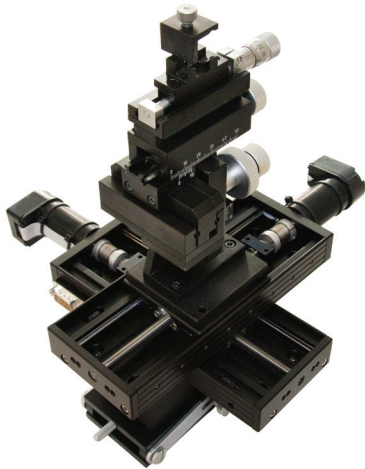

# ASSEMBLY PROCEDURE 3D MOTORIZED SYSTEM

1. Mount the 3D arm on the vertical post of the Laboratory Stand. To do this, put the aluminium finger bolts into the holes on the 3D arm and mount the elongated nuts by one to two rounds. Slide the nuts into the groove of the stand. Position the arm horizontally and tighten the aluminium finger bolts well with the provided tool.
2. Mount the first Motor Stage (MMS) on the 3D arm using 4 of the long 4 mm bolts. Move the moving stage on the MMS to one side by rotating the spindle by hand. This will expose two of the fixing holes (see picture). Mount the 2 bolts and move the moving stage to the other side to expose the other two fixing holes and mount the bolts.

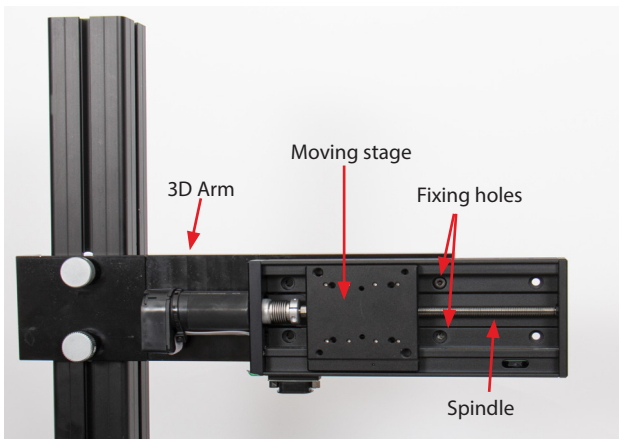

3. Mount the 3D angle on the first MMS. This is fixed using two 6 mm bolts as indicated in the picture.

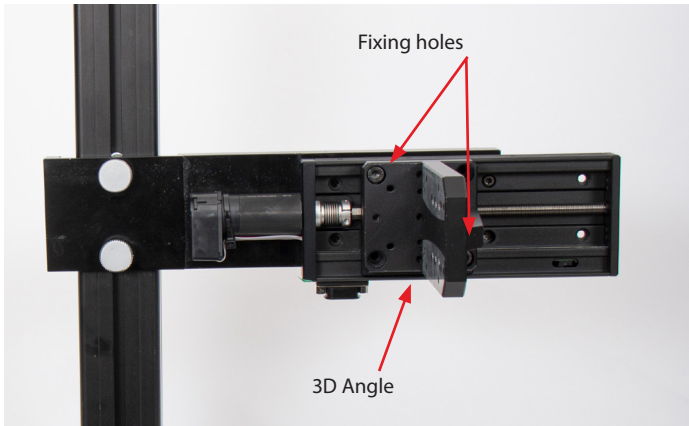

4. Mount the second MMS on the 3D angle using two long 4 mm bolts (see picture). Make sure the second stage is horizontal and tighten the bolts well.

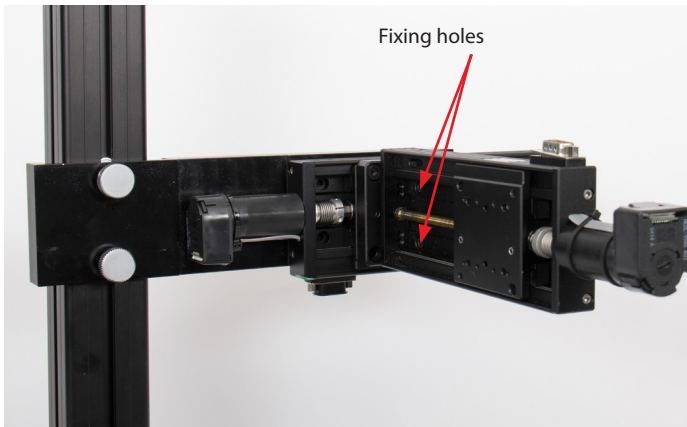

5. Mount the micromanipulator on the third MMS. First remove the tilting base from the micromanipulator, mount the square plate on the micromanipulator with 2 short

4 mm bolts. Then mount the square plate to the moving stage of the MMS with two long 4 mm bolts (see picture and Assembly procedure 1D motorized system above).

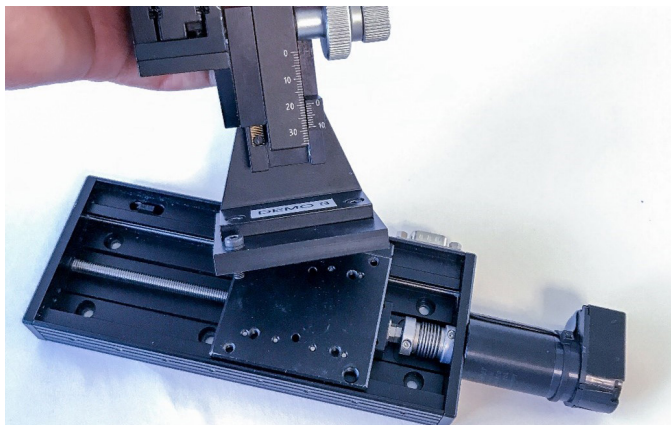

6. Mount the third MMS with micromanipulator on the second MMS with the spindles on the two perpendicular to each other (see picture). The third MMS must be fixed with 4 of the short 4 mm bolts. To get access to the fixing holes, move the moving stage to one side, rotating the spindle by hand. Then mount the two bolts and move the moving stage to the other side and mount the last two bolts.

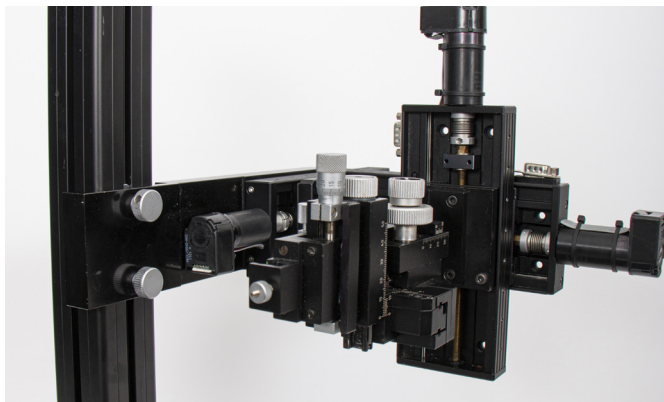



7. Connect the motors to the motor controllers using the supplied cables (see Setting up above)



## STORAGE AND MAINTENANCE

Unisense recommends that the micromanipulator, lab stand, and in situ stand are protected with silicone spray before use. This will help to keep the surfaces clean and will prolong the lifetime of the unit.

Rinse the micromanipulator and stands with distilled water if salt or other corrosive material have been deposited on them.

Keep the micromanipulator and motor free of sand and dust.

### **WARNING**

*Do not spray the MMS with silicone*

### **IMPORTANT**

*If you encounter problems that cannot be solved from the troubleshooting sections of the individual manuals, please contact [sales@unisense.com](mailto:sales@unisense.com) for support (we will try to answer you within one workday)*







**UNISENSE**

UNISENSE, DENMARK

[www.unisense.com](http://www.unisense.com) · [info@unisense.com](mailto:info@unisense.com)