

# Model T300 Fixed Temperature Rate Compensated Heat Detector



Shown with optional  
junction box

- **Responds accurately and positively to fire threats. . . virtually eliminates costly false alarms**
- **Repeatable – resets itself, nothing to replace, can be tested**
- **Rugged – withstands shock and vibration**
- **Versatile – available in a wide range of temperature settings**
- **Explosion proof – Underwriters Laboratory listed approved for hazardous locations**
- **Durable – long lasting stainless steel construction, hermetically sealed**
- **Accurate – factory set to respond at rated temperature, regardless of the rate of temperature rise; not sensitive to momentary changes in temperature**



Class I Groups B,C,D  
Class II Groups E,F,G

The SST Model T300 detectors are highly reliable thermal detection devices which have been a standard of the fire protection industry for over 30 years. They may be used as an alarm device, to sense overheat or fire and alert personnel via the Safety Systems NOVA-5000 Fire Detection and Control System, or they may be used to sense a fire and actuate the release of extinguishing agent. These units are designed with rate compensation. This provides a unique advantage over both fixed temperature and rate-of-rise types of detectors, allowing these detectors to accurately sense the surrounding air temperature regardless of the fire growth rate.

*Fixed temperature* detectors must be completely heated to alarm temperature before responding, and therefore, a disastrous time lag may occur with a fast rate fire. *Rate-of-rise* devices, on the other hand, are triggered by the rate of increase in ambient temperature and are subject to false alarms caused by harmless transient thermal gradients, such as the rush of warm air from a process oven. By contrast, the SST Model T300 *fixed temperature rate compensated* detectors have the inherent ability to operate whenever the surrounding air temperature reaches the selected protection level, even if this rise is so fast that the body of the detector is not completely heated. At the same time, the SST detectors will not respond to sudden temperature changes below the selected rating of the detector.

## APPLICATION INFORMATION

The Model T300 Fixed Temperature Rate Compensated Heat Detectors are designed for use in both “ordinary” and hazardous locations. For ordinary use, they may be mounted to any standard electrical junction box with a 7/8 inch opening using a standard electrician’s connector nut. For hazardous locations, where “explosion-proof” construction is required, the detectors must be installed in a 1/2 inch threaded opening in a suitable listed fitting in accordance with the National Electric Code and/or the local authority having jurisdiction.

To meet the spacing requirements of UL for these detectors, they should be spaced no more than 25 feet apart in the protected area. This rating is based on being located on a smooth ceiling, with the distance between the detector and any wall or partition no more than 12.5 feet. In open joist or beam construction, closer spacing is required. For applications in normal areas where ceiling temperatures do not normally exceed 100°F, the 140°F rated detector is recommended. For all other areas, the temperature rating of the selected detector should be 50 to 100 degrees greater than the highest expected ambient temperature. The end of the detector is color coded according to the rated temperature. This is to allow easy inspection after initial installation for proper temperature range.

**LIFE SAFETY:** Heat detectors protect property only. In most fires, hazardous levels of smoke, heat and toxic gasses can build up before a heat detector would initiate an alarm. In cases where life safety is a factor, smoke detectors are recommended.



## ARCHITECT'S AND ENGINEER'S SPECIFICATIONS

Thermal (Heat) fire detection capability shall be provided by fixed temperature rate compensated heat detectors for locations indicated on the plans. The detectors shall be self restoring, and designed to activate at the rated temperature regardless of the rate of fire propagation. Fixed temperature detectors without rate compensation or rate-of-rise detectors shall not be acceptable. Stainless steel hermetically sealed construction shall be used to insure corrosion resistance and reliability. The detector shall be UL listed approved for use in Class I, Groups B, C or D and Class II, Groups E, F or G hazardous locations. The specified detector shall meet the seismic requirements of IEEE standard 334. Safety Systems Technology Model T300 Fixed Temperature Rate Compensated Heat Detectors, or approved equivalents, shall be supplied.

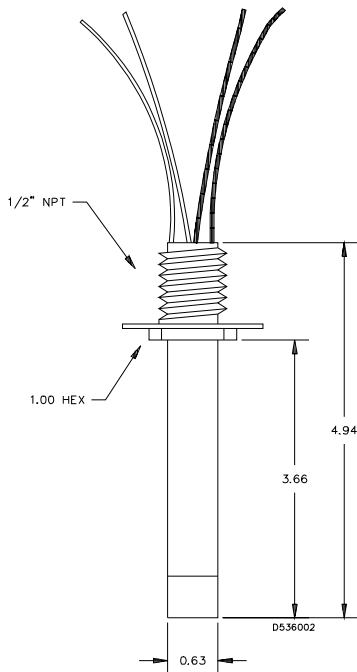

## TECHNICAL SPECIFICATIONS

Detection Method:	Fixed Temperature Rate compensated thermal (heat) detector Provides faster and more reliable fire detection than other types, with no tendency to false alarm.
Rated Alarm Temperature:	Factory preset See ordering information for available settings.
Contact Type:	Normally Open, self restoring Contact closes when air temperature is greater than the rated alarm temperature, and reopens when temperature falls below the rated temperature.
Contact rating:	2 amps @ 24 VDC, 1 amp @ 48 VDC, 0.5 amp @ 125 VDC, 5 amps @ 125 VAC When used with NOVA-5000 System, switched current is limited to 24 mA by 1000 ohm "in-line" resistor in series with contact.
Material:	Stainless Steel sensing shell Temperature setting is stamped on hex mounting flange.
Hazardous Locations:	Class I Groups B,C,D, and Class II Groups E,F,G. May also be used in non-hazardous locations.
Size/Weight:	0.63 inch diameter, 3.66 inches long, 5.4 ounces Extends 1.25 inches into junction box.

## ORDERING INFORMATION

The temperature rating of the selected detector should be 50 to 100 degrees F greater than the highest expected ambient temperature.

PART NUMBER	DESCRIPTION
300-140	Model T300 Fixed Temperature Rate Compensated Heat Detector, 140°F, 60°C.
300-190	Model T300 Fixed Temperature Rate Compensated Heat Detector, 190°F, 88°C.
300-225	Model T300 Fixed Temperature Rate Compensated Heat Detector, 225°F, 107°C.
300-325	Model T300 Fixed Temperature Rate Compensated Heat Detector, 325°F, 163°C.

## OPTIONAL ACCESSORIES

350-1	Junction Box with mounting ears and terminal block for sensor connections. Copper free Aluminum. Class I Groups C,D. Two ¾ inch NPT connections for conduit or cable glands.
-------	------------------------------------------------------------------------------------------------------------------------------------------------------------------------------

