

Strobe Light BLK

Robust optical signalling device for indoor and outdoor applications

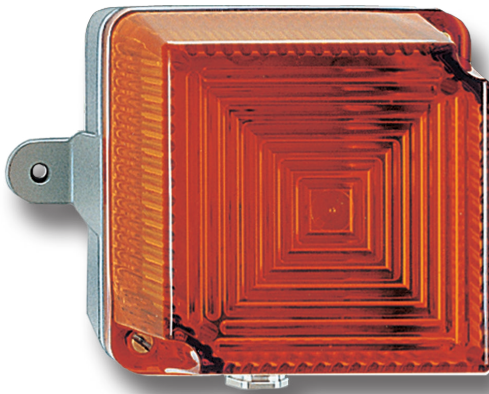

Übersicht

Optical signalling is often required for warning or notifying purposes in particularly noisy areas. The BLK Strobe Light provides clearly visible signals for that purpose. The sturdy housing of ingress protection IP 65 is suitable for both indoor and outdoor applications. The signalling light is available in 5 different colours.

The modern electronics are mounted on a printed circuit board of glass fibre reinforced epoxy resin. A powerful electronic flash tube converts the electrical energy stored in the flash capacitor into high-efficiency light flashes. The weatherproof coated aluminium die-cast housing is equipped with a ribbed cap made of impact-resistant plexi-glass. The strobe light is provided with a M20 cable gland for cable diameters of 8 to 12 mm.

Features

- Ingress protection IP 65
- Compensation valve to prevent condensation water
- Types BLK 32 and BLK 42 for extended temperature range of -50 °C to +50 °C
- Flash energy 5 Joule, 15 Joule

Specifications

Housing	Seawater-resistant aluminium, weatherproof varnish	
Colour	Light grey	
Cap	Plexiglass (Makrolon for BLK 32/42)	
Cap colour	Transparent, red, amber, green, blue	
Ingress protection	IP 65 according to EN 60529	
Protection class	I	
Cable gland	1 x M20 for cable diameters 8-12 mm	
Connection terminals	Terminal capacity: 2.5 mm ² single wire 1.5 mm ² fine-wire	
Flash energy	BLK 30/40, 32/42: 5 joule BLK 50/60: 15 joule	
Flash frequency	BLK 30/40, 32/42: 60/min BLK 50/60: 30/min	
Operating conditions	Indoors and outdoors	
Operating position	Any (preferably with cable gland facing downward)	
Operation mode	BLK 30/40, 32/42: continuous operation BLK 50/60: short term operation 5 minutes	
Temperature range	BLK 30, 40, 50, 60	BLK 32, 42
Operation	-30 °C to +50 °C	-50 °C to +50 °C
Storage	-30 °C to +70 °C	-50 °C to +70 °C
Weight	Approx. 0.7 kg	

General arrangement drawing (all dimensions in mm)

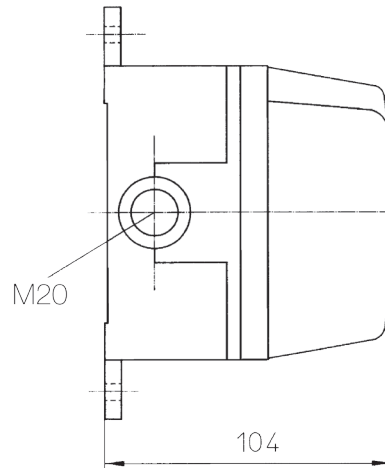
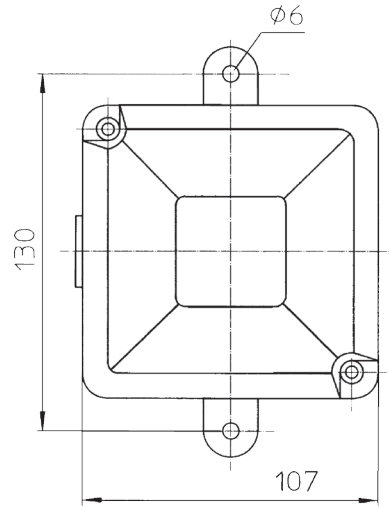

Ordering data

* The full article number is made up by appending the colour code to the article numbers given below.

Type	Designation	Input voltage	Tolerance	Current consumption	Si 5 x 20	Art. No.*
BLK 30	Strobe Light	24 VAC, 50-60 Hz	15-32 V	0.50 A	T 2.0/250 H	FHF 224 110 ..
BLK 30	Strobe Light	230 VAC, 50-60 Hz	-10/+6 %	0.07 A	T 2.0/250 H	FHF 224 112 ..
BLK 32	Strobe Light	230 VAC, 50-60 Hz	-10/+6 %	0.07 A	T 2.0/250 H	FHF 224 212 ..
BLK 40	Strobe Light	12 VDC	9-16 V	0.70 A	T 1.0/250 H	FHF 224 113 ..
BLK 42	Strobe Light	12 VDC	9-16 V	0.70 A	T 1.0/250 H	FHF 224 213 ..
BLK 40	Strobe Light	24 VDC	15-32 V	0.30 A	T 2.0/250 H	FHF 224 114 ..
BLK 42	Strobe Light	24 VDC	15-32 V	0.30 A	T 1.0/250 H	FHF 224 214 ..
BLK 40	Strobe Light	48 VDC	33-60 V	0.18 A	T 2.0/250 H	FHF 224 115 ..
BLK 50	Strobe Light	230 VAC, 50-60 Hz	-10/+6 %	0.25 A	T 2.0/250 H	FHF 224 122 ..
BLK 60	Strobe Light	24 VDC	16-30 V	0.90 A	T 2.0/250 H	FHF 224 124 ..

transparent	01
red	02
amber	03
green	04
blue	05