



RIFTEK
Sensors & Instruments



LASER WHEEL PROFILOMETER

IKP-5 Series, Model 2017 Year

User's manual

Contents

1.	Safety precautions and measurement conditions.....	5
2.	CE compliance.....	5
3.	Laser safety.....	5
4.	General information.....	5
5.	Basic technical data.....	6
6.	Example of designation when ordering.....	7
7.	Complete set to be supplied.....	7
8.	Device structure.....	8
8.1.	Basic components of the device and their functions.....	8
8.1.1.	Digital readout device.....	9
8.1.2.	Laser scanning module.....	10
8.1.3.	Calibration block.....	12
9.	Operation principle.....	12
10.	Geometric parameters of the wheel under control.....	12
10.1.	Flange height, sH.....	12
10.2.	Flange thickness, sD.....	13
10.3.	Flange slope, qR.....	14
10.4.	Wear parameters.....	14
10.5.	Angle parameters.....	15
10.6.	Rim parameters.....	16
10.7.	Wheel diameter.....	16
10.8.	Parameters of tram wheels.....	16
10.9.	Wheel defects.....	17
11.	Coordinate system.....	17
12.	First activation and measurement procedure.....	18
12.1.	Activation.....	18
12.2.	Measurement.....	19
13.	PDA program setting.....	21
13.1.	Measurement type.....	21
13.2.	Units of measurement.....	21
13.3.	Date/time setting.....	22
13.4.	Device selection.....	22
13.5.	Language setting.....	24
13.6.	Synchronization with PC.....	24
14.	Measurement parameters setting.....	25
14.1.	Calculation methods setting.....	26
14.2.	Selection of displayed parameters.....	26
14.3.	L-parameters setting.....	26
14.4.	Preset parameters values.....	27
15.	Setting the database parameters, tolerances and measurements schemes.....	28
15.1.	Selection of the current database.....	28
15.2.	Reference profile selection and installation.....	29
15.2.1.	Writing the reference profile to the database.....	30
15.3.	Selection and formation of the measurement scheme.....	30
15.3.1.	Selection or removal of the measurement scheme.....	30
15.3.2.	Formation of a new measurement scheme.....	31
15.3.3.	Loading of a new measurement scheme.....	31
15.4.	Setting of tolerances.....	31
15.5.	Wheel type selection and installation.....	32
16.	Updating of PDA software.....	33
17.	Shutdown.....	34
18.	Measurements with database maintenance.....	34

18.1.	Measurement.....	35
18.2.	Measurement of even/uneven wear.....	37
18.3.	Measurement of defects.....	38
19.	Measuring by IKP, IDK, IMR, and saving to database.....	39
20.	Browsing the database.....	39
20.1.	Data filtering.....	40
20.2.	Visualization of the wheel profile.....	40
21.	Installation of software on PC and startup.....	41
21.1.	Installation of database support software.....	41
21.2.	Synchronization of PDA and PC.....	41
21.3.	Program startup.....	42
22.	User settings of the program.....	43
22.1.	Parameters setting.....	43
22.1.1.	"Wheelset's parameters" tab.....	43
22.1.2.	"Calculated parameters" tab.....	44
22.1.3.	"L-parameters" tab.....	44
22.1.4.	"Measurement method" tab.....	44
22.1.4.1.	Selection of measurement units.....	45
22.2.	Database settings.....	45
22.2.1.	Setting the path to database.....	45
22.2.2.	Creation of empty database.....	46
22.2.3.	Import of database.....	46
22.2.4.	Selection of software language.....	46
22.2.4.1.	Preparation and installation of the language support file.....	47
22.3.	Registration data.....	47
22.3.1.	Selection of the organization.....	47
22.3.2.	Registration of operators.....	48
22.3.3.	Registration of series.....	48
22.3.4.	Registration of car/locomotive numbers.....	49
22.3.5.	Registration of tolerances.....	49
22.3.6.	Registration of reference profiles.....	49
22.3.6.1.	Request and registration of the profile file.....	50
23.	Data exchange between PDA and PC.....	51
23.1.	ActiveSync synchronization.....	51
23.1.1.	Transfer of database file to PC.....	51
23.1.2.	Transfer of language file from PC to PDA.....	52
23.1.3.	Transfer of language file from PDA to PC.....	53
23.1.4.	Transfer of reference profile files from PC to PDA.....	53
23.1.5.	Transfer of processing scheme file from PC to PDA.....	54
23.1.6.	Updating of PDA software.....	54
23.2.	Mass Storage synchronization.....	55
24.	Working with profilograms and wear calculations.....	56
24.1.	Browsing the graph and profile coordinates.....	56
24.2.	"Parameters" tab.....	57
24.2.1.	Selecting a profile to compare.....	57
24.2.2.	Selecting L-parameters values.....	57
24.2.3.	Geometric parameters of the profile.....	58
24.3.	Wear calculation.....	58
24.3.1.	Fast wear calculation.....	58
24.3.2.	Wear calculation at all points.....	59
24.3.3.	Export to Excel, DXF, REF.....	59
24.4.	Alignment of profiles.....	60
24.5.	Superposition of profiles.....	61
24.6.	Rescaling.....	61
25.	Implementation of minimum wheel truing function.....	61
26.	Scanning and editing of data.....	63
26.1.	Scanning and filtering of data.....	63

- 26.2. Editing data..... 64
- 26.3. Report preparation 65
 - 26.3.1. Excel-format report..... 66
 - 26.3.2. Report for printout..... 66
- 27. Taking measurements under PC control (without PDA).....67
 - 27.1. Calibration..... 68
 - 27.1.1. Bluetooth-connection..... 68
 - 27.1.2. Calibration of the profilometer..... 69
 - 27.2. Measurement by using PC..... 70
 - 27.2.1. Saving of data..... 70
- 28. Annex 1. Charging procedure.....71
- 29. Annex 2. Program for creating the measurement schemes.....71
- 30. Annex 3. Testing and calibration.....73
 - 30.1. Preparation for testing/calibration..... 73
 - 30.2. Testing..... 74
 - 30.3. Calibration..... 76
 - 30.4. Restoring the factory settings..... 77
- 31. Annex 4. Software application for working with the "A.U.R.A. Wheel" system78
 - 31.1. Installation..... 78
 - 31.2. Settings..... 78
 - 31.2.1. Language 79
 - 31.2.2. Gauge type selection..... 79
 - 31.2.3. Password..... 82
 - 31.2.4. Calculation methods..... 83
 - 31.2.5. Selection of displayed parameters..... 83
 - 31.2.6. L-parameters..... 84
 - 31.2.6.1. Preset values..... 84
 - 31.2.7. Reference profile selection and installation..... 85
 - 31.2.7.1. Writing the reference profile to the database..... 85
 - 31.2.8. Measurement scheme..... 85
 - 31.2.8.1. Selection or removal of the measurement scheme..... 86
 - 31.2.8.2. Formation of a new measurement scheme..... 86
 - 31.2.9. Tolerances..... 87
 - 31.2.10. Vehicles 88
 - 31.3. Measurements..... 88
 - 31.3.1. Single measurement..... 89
 - 31.3.2. Simple measurement..... 90
 - 31.3.2.1. Measurement..... 92
 - 31.3.2.2. Measuring by IDK, IMR..... 95
 - 31.3.3. Automated measurement..... 96
- 32. Warranty policy.....98
- 33. List of changes98

1. Safety precautions and measurement conditions

- Prior to mounting the profilometer onto the wheel, areas of contact of the side supports with the wheel surface should be thoroughly cleaned from dirt.
- When mounting the module on the wheel, do not allow heavy shocks of its support against the wheel.
- The output window of the profilometer and profilometer supports must be carefully inspected and cleaned.
- Do not use laser module in locations close to powerful light sources.

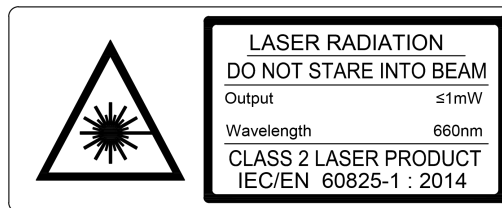
2. CE compliance

The profilometers have been developed for use in industry and meet the requirements of the following Directives:

- EU directive 2014/30/EU. Electromagnetic compatibility (EMC).
- EU directive 2011/65/EU, “RoHS” category 9.

3. Laser safety

The profilometer makes use of an c.w. 660 (or 405) nm wavelength semiconductor laser. The maximum output power is 1 mW. The device belongs to the 2 laser safety class according IEC/EN 60825-1:2014. The following warning label is placed on the profilometer body:



The following safety measures should be taken while operating the profilometer:

- Do not target the laser beam to humans.
- Do not disassemble the sensor.
- Avoid staring into the laser beam.

4. General information

A laser profilometer IKP5 Series is designed for measuring of

- wheel flange height
- wheel flange thickness
- wheel flange slope
- rim thickness
- full profile scanning and analyze of wheel rolling surface
- maintaining of electronic wear data base
- control of tolerances and sorting in the course of checkup, examination, repair and formation of railway wheel sets.

Measurements are made directly on rolling stock without wheel set roll-out.

Profilometers are implemented in three configurations: with the standard handle, with the shorten handle (Short version) and very short handle (Super short version) . The version with the shorten handle is intended to measure the wheels with the limited space for installing the profilometer. The version with very short handle is specially designed to measure wheels of **Ansaldo Breda low floor trams** with very limited space for profilometer installing. This super short profilometer version has separate battery block, connected by cable with laser module.

5. Basic technical data

Name of parameter	Value
<i>Measurement range</i>	
Flange height, mm	20...45
Flange thickness, mm	20...50
Flange slope, mm	1...15
Rim thickness, mm	36...100 (30...90)
Diameter (calculation method), mm	400...1400
<i>Measurement error</i>	
Flange height, mm	± 0.03
Flange thickness, mm	± 0.03
Flange slope, mm	± 0.1
Rim thickness, mm	± 0.1
Diameter, mm	± 0.1
<i>Discreteness of indication</i>	
All parameters, mm	0.01
Profile measurement range, mm	145
Discreteness of the profile formation, not worse than, mm	0.025 (5800 points for profile)
Digital readout device (PDA) dimensions, mm	see Fig. 3
Dimensions of laser scanning module, mm	see Fig. 5
Measurement time, s	adaptive, depending on surface quality, 4 average
Power supply (laser scanning module)	3.7V Li-ion rechargeable battery 5400mAh for standard IKP and 2400mAh for Short and Super-short
The number of measurements that can be taken before battery recharge is not less than	5000 for standard IKP and 2200 for Short and Super-short
Laser module battery life time	5 million measurement cycles
Power supply (PDA)	3.7V Li-polymer battery 3300mAh
PDA memory capacity	100 000 measurements
Interface between laser scanning module and PDA	Bluetooth
Working temperature range, °C	-20...+50
Enclosure rating	IP42 or IP64

6. Example of designation when ordering

IKP-V-M-S-T-R

Symbol	Description
V	Profilometer version: without symbol - Standard version Short - Short handle SShort - Super short handle SShort-EB - Super short handle and external battery
M	Options of the set of magnets for mounting on the internal/external rim face: S – standard. Standard magnets (specified by default). F – forced. Reinforced magnets.
S	Options of the support plates embodiment: D – direct. Standard plates, profilometer is mounted on the internal rim face (specified by default). I – invert. Custom plates, profilometer is mounted on the external rim face.
T	Presence of the rim measurement rod.
R	Enclosure rating: without symbol - IP42 64 - IP64

Example:

IKP-T – standard magnets; standard support plates; presence of the rim measurement rod.

IKP-F-I – reinforced magnets; custom support plates.

IKP-Short-T - the shorten handle; presence of the rim measurement rod.

7. Complete set to be supplied

Designation	Name	Quantity	Weight, kg
RF303M	Digital readout device (PDA)	1	0.3
RF505	Laser scanning module	1	0.8
RF505.40	Charging device 5V 1.0A for PDA and laser module	2	0.2
RF505.42	Data cable	1	
RF505.43	Bluetooth adapter	1	
RF505.30	Packing case	1	1.2
IKP5_DB	Database management system (CD)	1	
RF505UM	User's manual	1	
	Calibration tools (option):		
RF505.11	Calibration block		4
RF505Calibr	Calibration software		

The profilometer comes in the special case that protects the device against any possible damage during transportation.

**8**

8. Device structure

8.1. Basic components of the device and their functions

Fig. 1 shows basic components of the device:



Figure 1

- (1) Digital readout device (personal digital assistant, PDA)
- (2) Laser scanning module
- (3) Calibration block
- (4) Charging device
- (5) Data cable

8.1.1. Digital readout device

Digital readout device (PDA) is designed for control of the laser scanning module, data reception from the scanning module, indication of measurement results, parameter input, and data storage.



Figure 2

Fig. 2 indicates:

- (1) Turn-on button
- (2) Charging indication, red/blue LED
- (3) Connector to PC USB-port or charging device
- (4) Flash memory card connector
- (5) Stylus
- (6) Bluetooth antenna

Overall dimensions of PDA are shown in Figure 3:

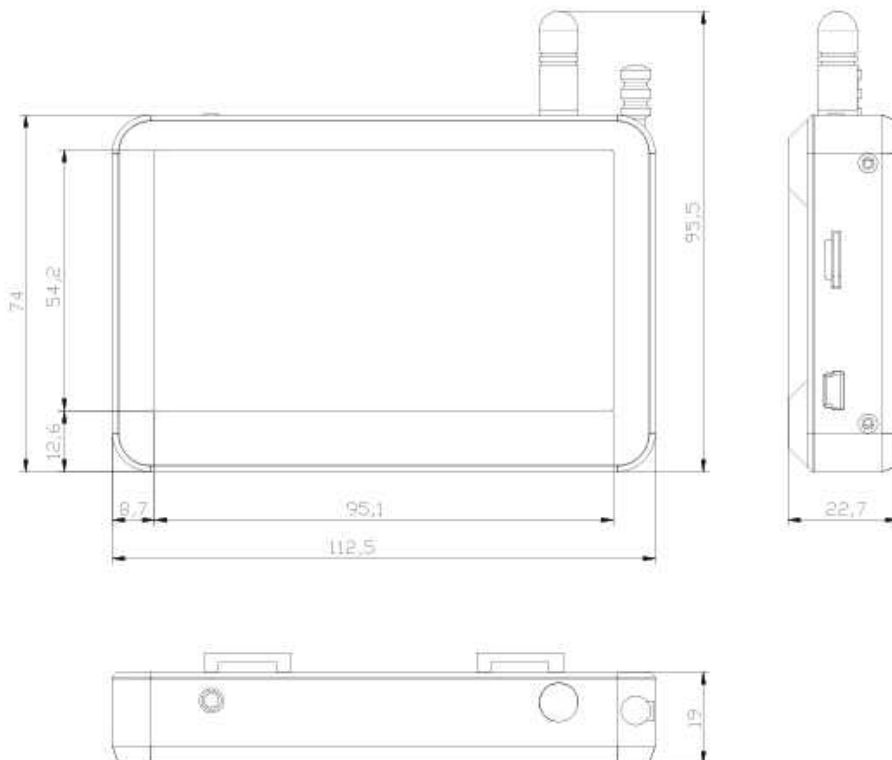


Figure 3

8.1.2. Laser scanning module

The module is intended for laser scanning of the wheel surface.

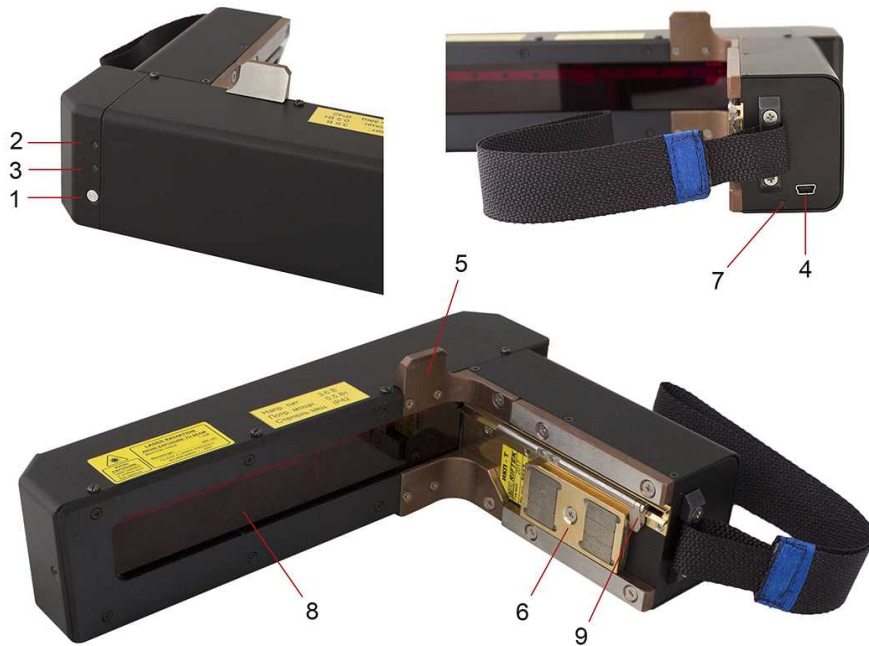


Figure 4

Fig. 4 indicates:

- (1) Turn ON button
- (2) Indicator of turn ON (red LED)
- (3) Indicator of Bluetooth connection (blue LED)
- (4) Charging device connector
- (5) Support for mounting of the device on the wheel flange
- (6) Magnetic support for mounting on the wheel side surface
- (7) Charging indication, red/green LED
- (8) Output window
- (9) Rim measurement rod

• **IKP-T**

Overall dimensions of the standard scanning module are shown in Figure 5.

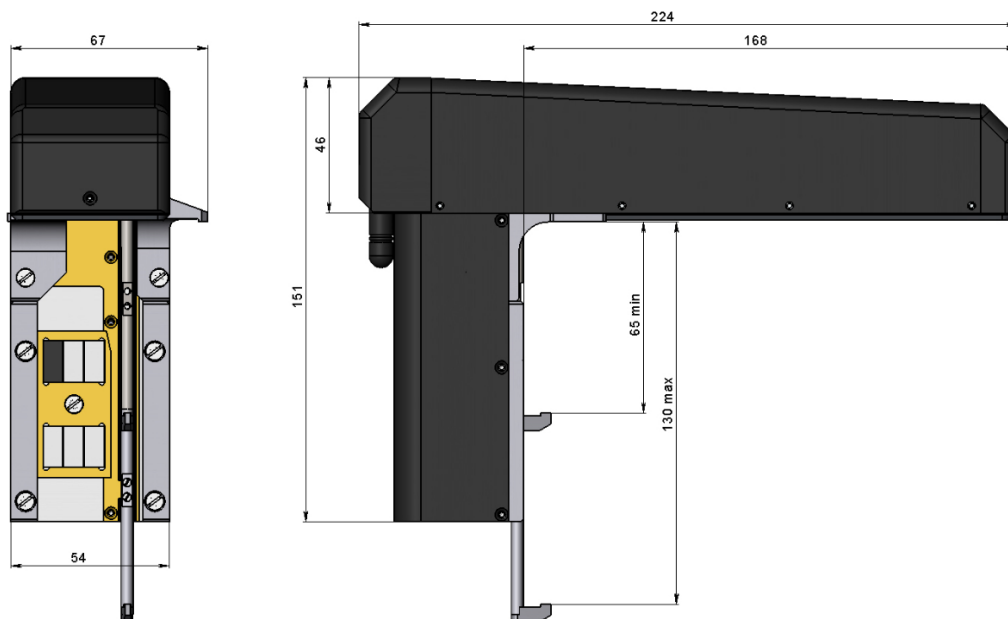


Figure 5

• **IKP-Short-T**

Overall dimensions of the scanning module with a short handle are shown in Figure

6.

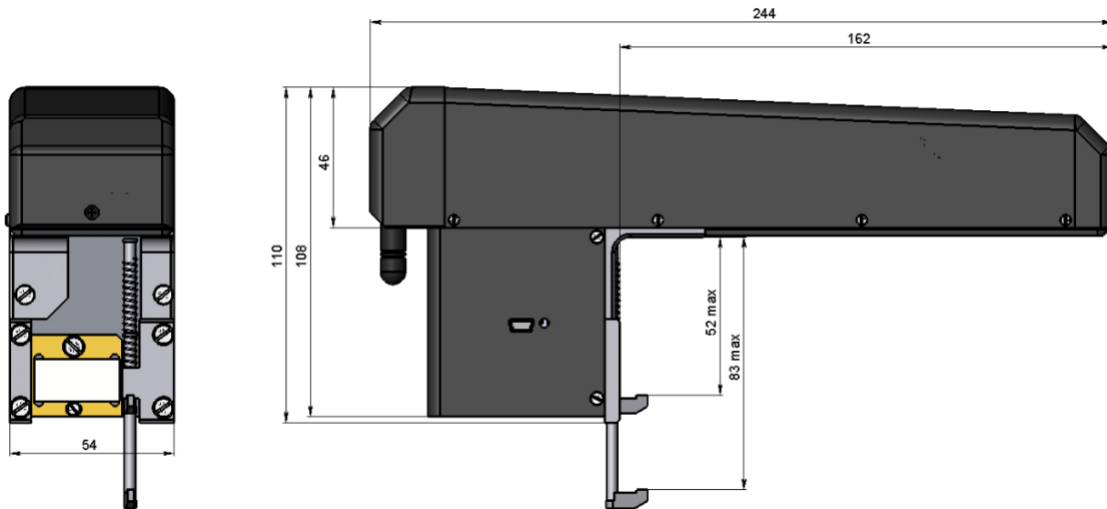


Figure 6

• **IKP-SShort**

Overall dimensions of the scanning module with a very short handle (Super Short version) are shown in Figure 6.1.

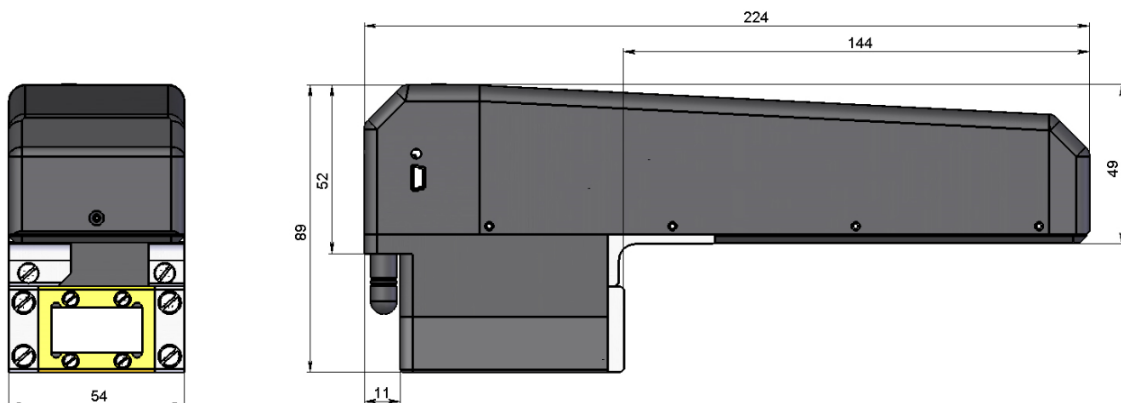
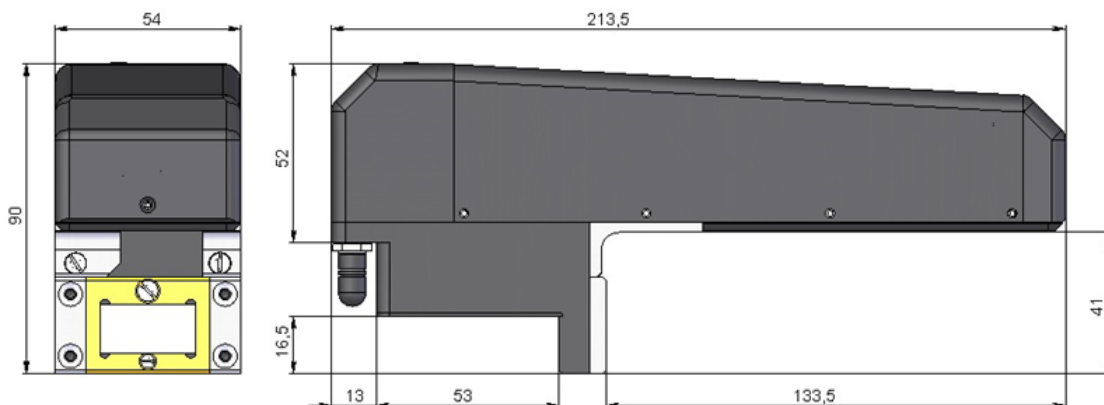


Figure 6.1

• **IKP-SShort-EB**

Overall dimensions of the scanning module with a very short handle and an external battery are shown in Figure 6.2.



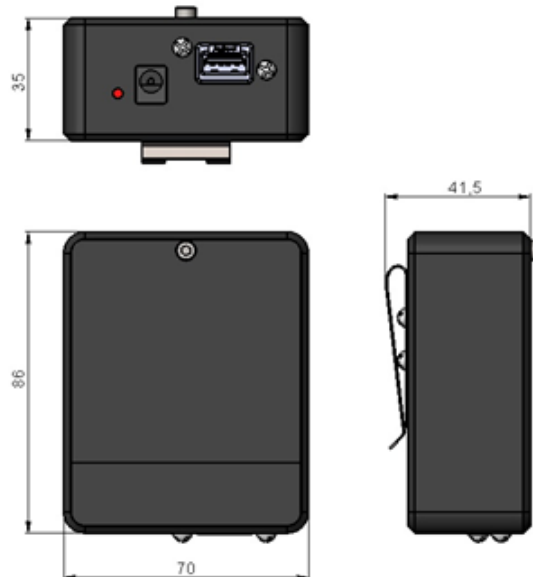


Figure 6.2

8.1.3. Calibration block

Calibration block is intended for calibration and tests of the profilometer. Calibration block is a metal imitator of the part of wheel with a definite profile.

Overall dimensions of calibration block are shown in Figure 1A of paragraph [30.3](#). Also possible is supply of a unit with a profile made to the customer's drawings.

9. Operation principle

Operator mounts the laser scanning module onto the wheel to be measured. Having received a command from PDA or PC, the laser module performs non-contact scanning of the wheel surface. Measurement results (geometric parameters and profile of the surface) are displayed on PDA, can be saved in the PDA memory, and transferred to the PC database. Simultaneously, additional parameters can be saved: operator number, side identifier (left or right wheel), axis number, locomotive (carriage) number, wheel pair number, etc.

Video demonstration: <https://riftek.com/eng/products/~show/instruments/railway-devices/railway-wheel-profile-gauge-ikp>

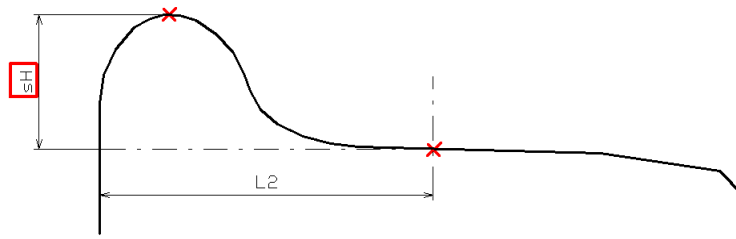
10. Geometric parameters of the wheel under control

Geometric parameters of the wheel are calculated automatically after laser scanning of the wheel is completed. To calculate geometric parameters, use is made of reference points on the wheel profile. Location of the reference points is defined by L- and P-parameters. Values of L- and P-parameters preset in PDA are given in paragraph [14.4](#). and can be changed by the user.

10.1. Flange height, sH

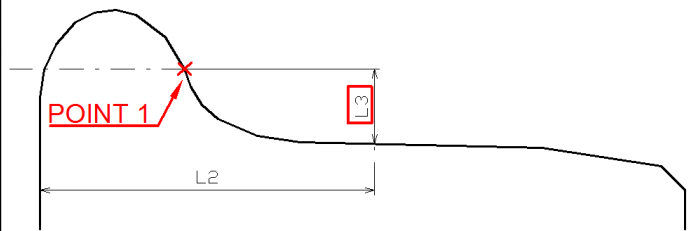
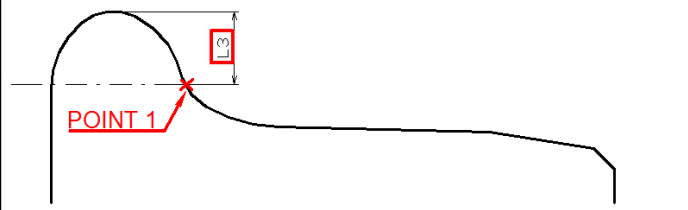
Calculation of the flange height is determined by parameter L2.

The flange height is calculated as a distance measured vertically between the flange top and the point of wheel rolling surface at any preselected distance (L2) away from the inner face of the wheel tire.



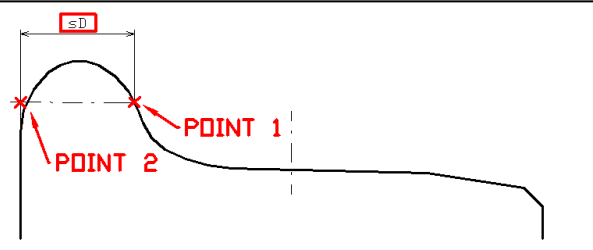
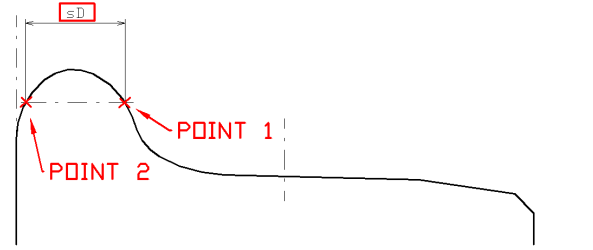
10.2. Flange thickness, sD

Calculation of the flange thickness is determined by parameter L3 that specifies Point 1 on the flange surface. There are two ways to specify the parameter:

Method 1	
Height L3 is measured vertically upward from a point of the wheel rolling surface, the position of which is defined by parameter L2.	
Method 2	
Height L3 is measured vertically downward from the flange top.	

The flange thickness is calculated as a distance measured horizontally at any preselected height (L3) between two points (Point 1 and Point 2) lying on the opposite sides of the flange top.

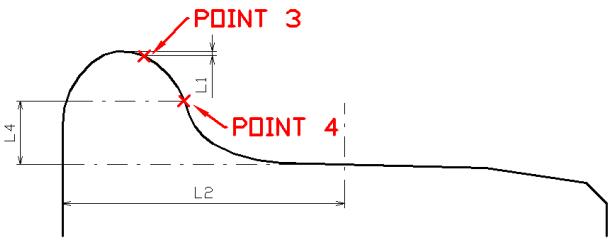
There are two ways to calculate the flange thickness:

Method 1	
Point 1 is defined by parameter L3. Point 2 is the intersection point of a horizontal line and a line lying on the internal face of the wheel.	
Method 2	
Point 1 is defined by parameter L3. Point 2 is the intersection point of a horizontal line and the flange surface.	

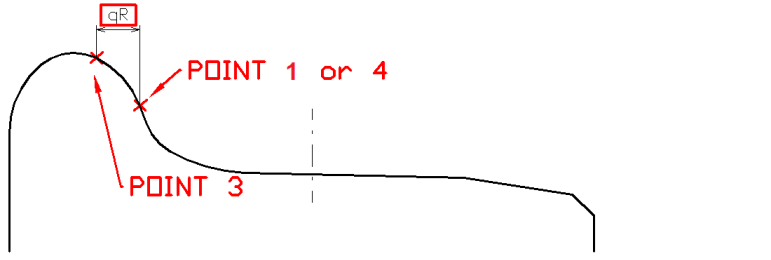
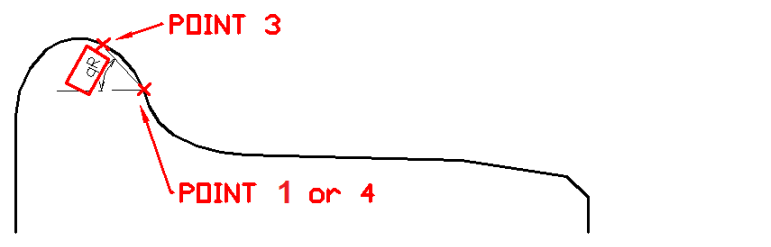
Note: Both calculation methods can be performed simultaneously.

10.3. Flange slope, qR

Calculation of the flange slope is determined by parameters L1 and L3 (or L4).

<p>Height L1 is measured vertically downward from the flange top and determines Point 3 on the flange surface.</p> <p>Height L4 is measured vertically upward from a point of the wheel rolling surface, the position of which is defined by parameter L2 (wheel rolling circle), and determines Point 4 on the flange surface.</p> <p>Height L3 is described in paragraph 10.2.</p>	
--	--

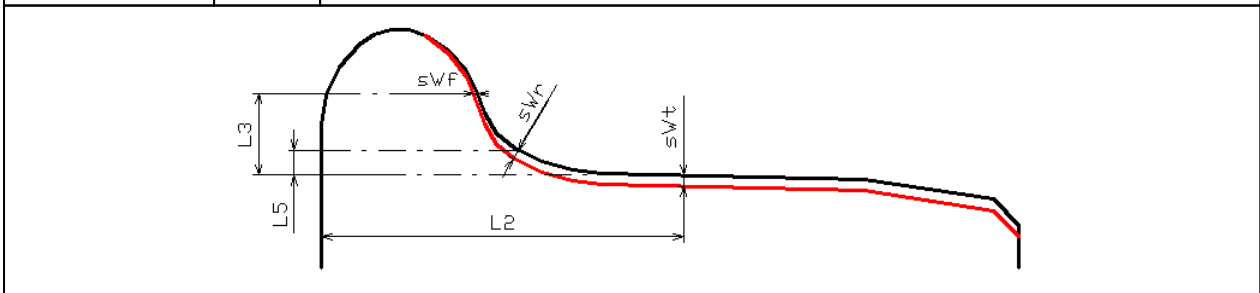
There are three ways to calculate the flange slope:

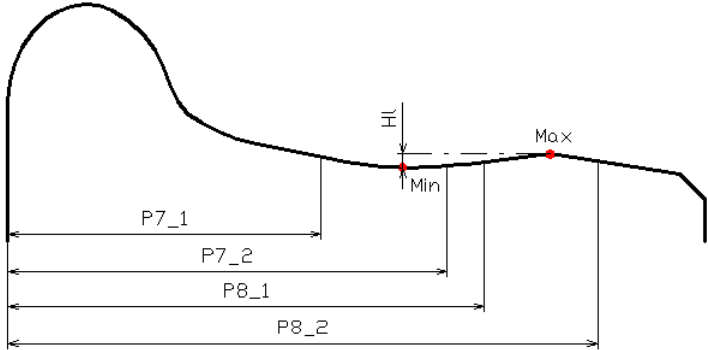
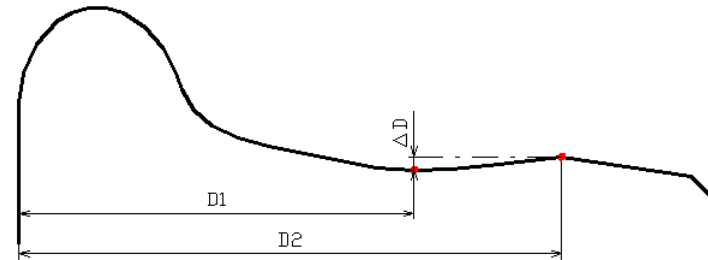
<p>Method 1 Calculation in millimeters</p> <p>The flange slope is calculated as a distance measured horizontally between Point 3 and Point 1 (or 4). The PDA screen displays information in millimeters.</p>	
<p>Method 2 Calculation in degrees</p> <p>The slope is calculated as the inclination angle of a straight line passing through Point 1 or 4. The PDA screen displays information in degrees.</p>	
<p>Method 3 Pass/Fail</p> <p>The calculation is performed according to Method 1. The PDA screen displays information only about whether the measured slope meets the tolerance conditions or not.</p>	

10.4. Wear parameters

The following wear parameters are calculated automatically:

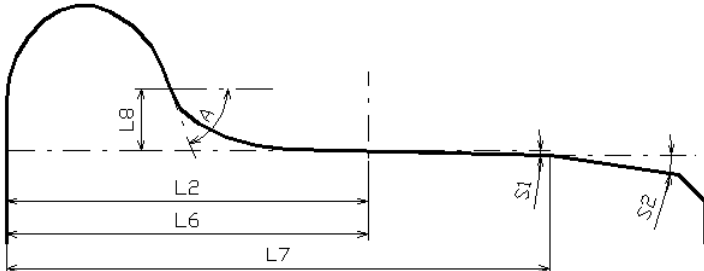
Vertical wear	Wt	is calculated as the difference between the measured flange height and the flange height of the selected reference.
Horizontal wear	Wf	is calculated as the difference between the measured flange thickness and the flange thickness of the selected reference at height L3.
Corner wear	Wr	is calculated as the distance along the normal to the tangent at the point at height L5 from the wheel rolling circle of the measured profile, and the selected reference.



* Red color indicates the worn profile		
Hollow	HI	is calculated as the difference between the maximum and minimum values within the specified limits. The search limits: - parameters of the minimum value [P7_1..P7_2] - parameters of the maximum value [P8_1..P8_2]
		
Difference of diameters	dD	is calculated as the difference between diameter at point D1 and diameter at point D2.
		
Even wear	W1	is the maximum vertical wheel wear selected from several measurements.
Uneven wear	W2	is the difference between the maximum wheel wear and the minimum wheel wear (selected from several measurements).

10.5. Angle parameters

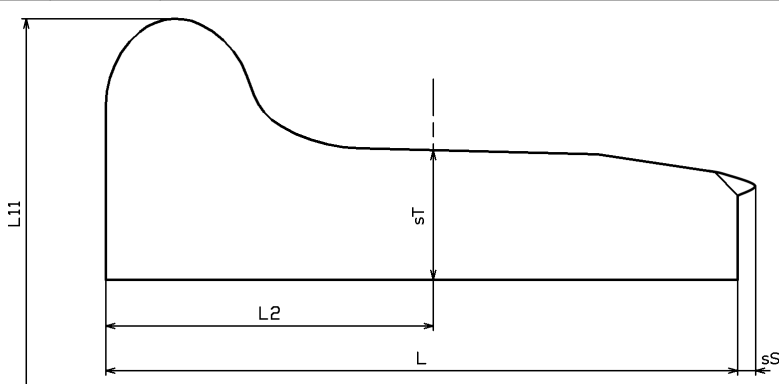
The following profile parameters are calculated automatically:

Inclination	A	is calculated as the profile inclination angle (in degrees) at a point with coordinate L8.
Angle 1	S1	is calculated as the inclination angle of the straight line (in percents) passing through points on the wheel surface located at preset distance L6 from the wheel face and the distance L6+10mm from the wheel face.
Angle 2	S2	is calculated as the inclination angle of the straight line (in percents) passing through points on the wheel surface located at preset distance L7 from the wheel face and the distance L7+10mm from the wheel face.
		

10.6. Rim parameters

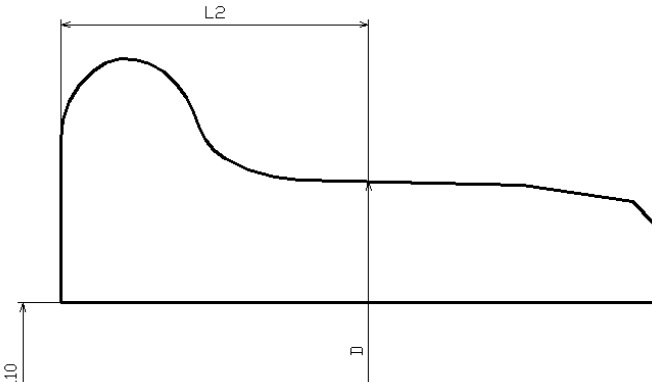
The following rim parameters are calculated automatically:

Rim width	L	is calculated as a distance measured horizontally between the internal and the external basic wheel surface.
Metal flow	sS	calculated as a distance measured horizontally between the external basic wheel surface and external maximum wheel width
Rim thickness	sT	is calculated as a distance measured vertically between the internal rim diameter and a point on the wheel rolling circle located on any preset distance L2 away from the wheel face. L11 is an external wheel diameter.



10.7. Wheel diameter

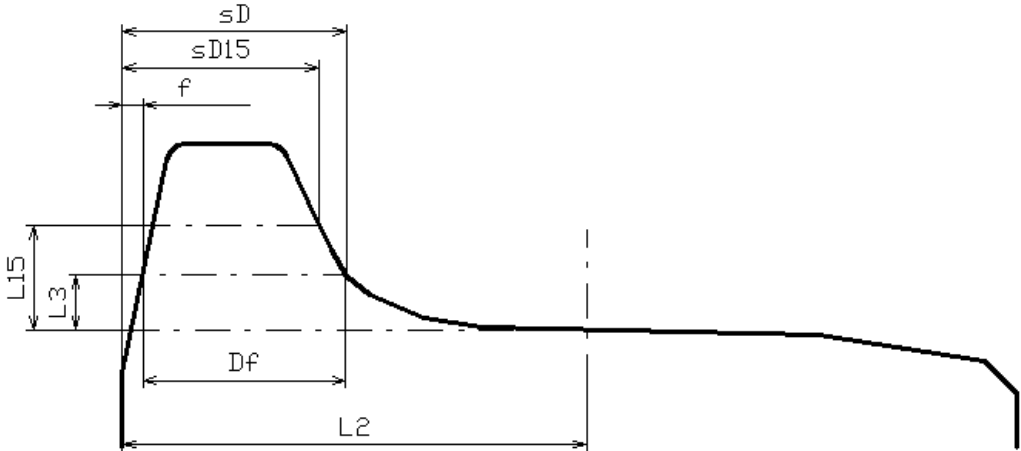
Diameter	D	is calculated by the formula: $D = 2 \cdot T + L10$, T – rim thickness L10 – diameter of the wheel center
----------	---	---



10.8. Parameters of tram wheels

The following parameters of the tram wheels profile are calculated automatically:

Flange thickness	sD15	is calculated as a distance measured horizontally at the set height (L15) between two points: 1st point is at the internal flange surface, 2nd point is at the line lying on the internal face of the wheel surface.
Flange thickness	Df	is calculated as a distance measured horizontally at the set height (L3) from the surface of the wheel rolling circle between two points lying on opposite sides from the flange top.

Reverse slope	f	is calculated as a distance measured horizontally from the point on the internal flange side at the set height (L3) to the point on the line lying on the internal face of the wheel.
		


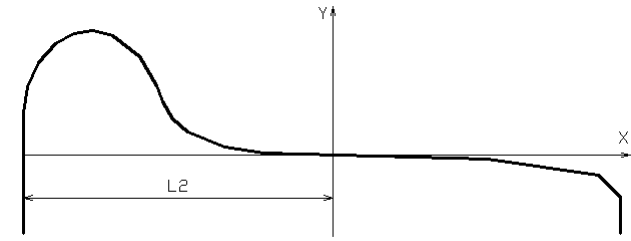
10.9. Wheel defects

The following parameters of defects of the wheel surface are calculated:

Slide	sP	is calculated as a difference of the wear measurements in two places of the wheel: on the slide and close to it (in the place without defects) at the point on the wheel rolling circle at any preset distance (L2) from the wheel face.
Cavity size	hR	is calculated as a difference of the wear measurements in two places of the wheel: on the cavity and close to it (in the place without defects) at any profile point.
Cavity area	sR	is calculated in the place of the maximum deviation.

11. Coordinate system

When comparing the profiles, two variants of location of the coordinate system of the wheel is possible to use.

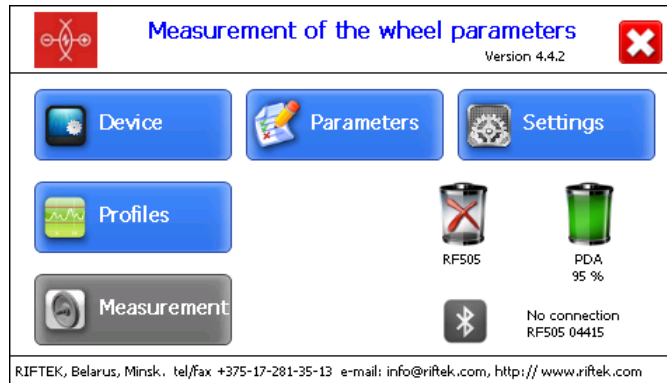
Coordinate system origin	
<p>Top</p> <p>When comparing and displaying profiles, the coordinate system origin is located at the intersection point of lines passing through the profile top and the internal wheel surface.</p>	
<p>Wheel rolling circle</p> <p>When comparing and displaying profiles, the coordinate system origin is located at the intersection point of lines passing through the wheel rolling circle.</p>	

12. First activation and measurement procedure

Charge accumulators of the laser module and indication device by connecting them to charging devices (see par. 28).

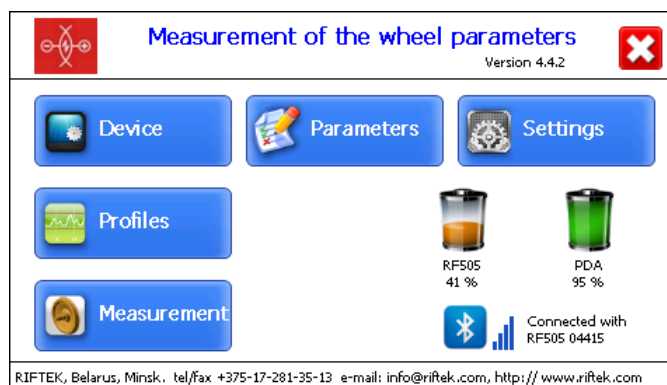
12.1. Activation

- Turn the PDA on by pressing the button (1), Fig. 2. The PDA screen will show the main program window containing: main menu; indicators of PDA and laser module charging degree; indicator of Bluetooth connection.



Button	Assignment
Device	Setting the PDA basic parameters (p.13)
Parameters	Setting the measurement parameters (p.14)
Settings	Setting parameters of database, tolerances, and others (p.15)
Profiles	View the wheelset profile (p.20.2.)
Measurement	Run the measurement process (p.12.2.)

- Switch the laser module on by pressing and holding button 1 (Fig. 4) for several seconds. When connecting the laser module, a red LED blinks (2).
- After the laser module is switched on, some time will pass until automatic wireless communication is set between the profilometer and the PDA, which is accompanied by blinking of a blue LED (3) on the laser module. The LED goes out when the link is established.
- The main program window will be updated.



The **Measurement** button, indicator of Bluetooth connection, serial number of the laser scanning module, and indicators of the charging degree will be active.

12.2. Measurement

There are two types of measurements:

1. Rapid measurements without saving the results.
2. Measurements by using the selected scheme with saving results to database.

The measurement procedure by using type 2 is described in par. [18](#). How to select the measurement type see in par. [13.1](#).

Measurement by using the scheme (type 2) is used for full-featured work with the profilometer with maintaining the database of measurements.

Attention!



Before installing the scanning module onto the wheel, you need to remove the dirt from the areas, where the laser scanning module will be in contact with the wheel surface. When installing the laser scanning module onto the wheel, avoid of strong impacts of its supports, because it can lead to incorrect operation of the profilometer.



You need to inspect periodically the output window and basic supports of the laser scanning module and to clean them of dirt. Do not clean the glass by using abrasive and aggressive cleaning agents.

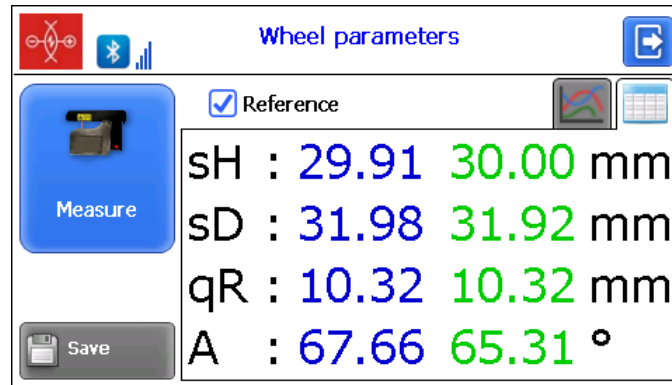
To perform the measurement, it is necessary to:

- Fix the laser module on the calibration unit or wheel by mounting the module support (5) onto the wheel flange and pressing magnetic support (6) to the internal face of the wheel.
- For the rim measurement, extract the rim measurement rod and hitch it up to the rim.

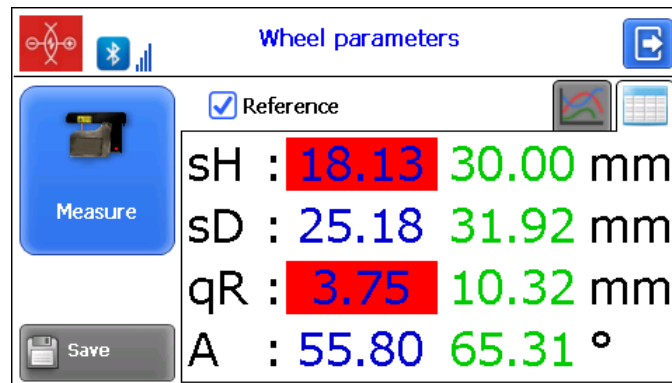


Figure 6

- Make sure that the module is mounted correctly without any misalignment and gaps.
- Press the **Measurement** button on the PDA display.
- With the **Measurement** button pressed, the laser module will scan the wheel surface. During scanning time of about 1-2 seconds a red LED (2) is lit.
- When scanning is completed, the PDA will show values of measured parameters selected for presentation (see par. [14.2](#)).

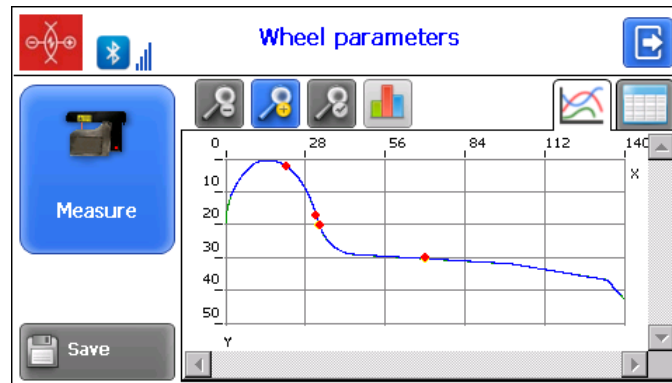


When the parameter goes beyond set limits its value is highlighted with red color:




The **Reference** option enables/disables the display of the reference profile parameters on the screen (highlighted in green).

- To view the wheel profile click the **Profile** button, and the PDA display will show the scanned wheel profile, the measured parameters, and parameters of calibration unit (or a wheel, chosen as a reference):



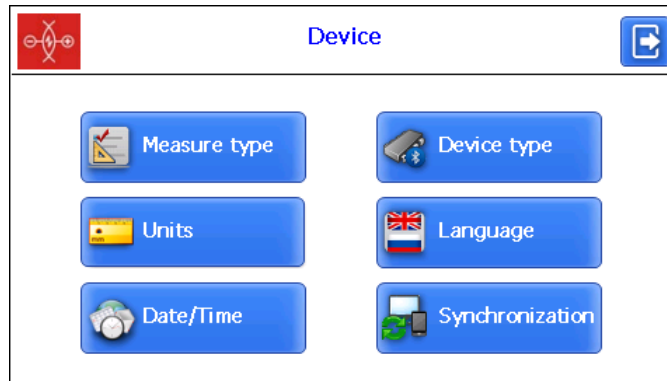
- If you scan the calibration block or the reference wheel and scanning results differ from the reference values by no more than 0.1 mm, the device is ready to work, otherwise it must be calibrated in accordance with par. [27.1](#) or [30](#).

 The **Save** button is not active in the **Rapid measurements** mode.

13. PDA program setting

Prior to starting work with the profilometer, PDA program setting must be performed.

The window of basic parameters setting is called by pressing the **Device** button in the main program window (par. 12.1.):



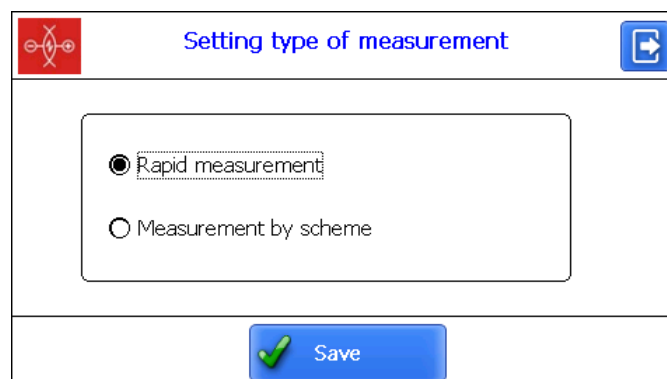
Button	Assignment
Measure type	Rapid measurements/measurements with saving results to database
Units of measurement	Millimeters/inches
Date/time	Date/time setting
Device type	Device selection (IKP, IDK, IMR)
Language	Language selection
Synchronization	Synchronization with PC

13.1. Measurement type

Two measurement types are available:

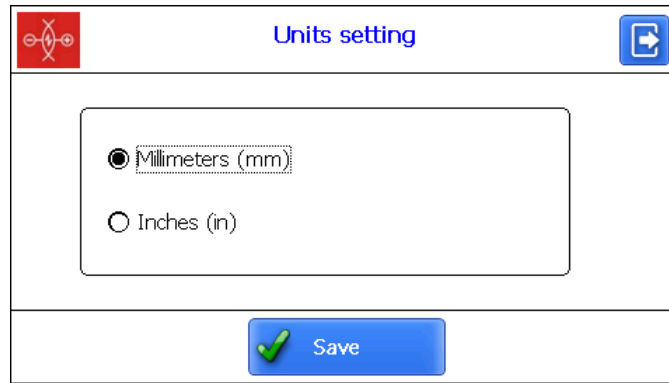
1. Rapid measurements without saving the results.
2. Measurements by using the selected scheme with saving results to database.

To set the measure type, press the **Measure type** button. Then select the measure type: **Rapid measurement** or **Measurement by scheme**. Press the **Save** button.





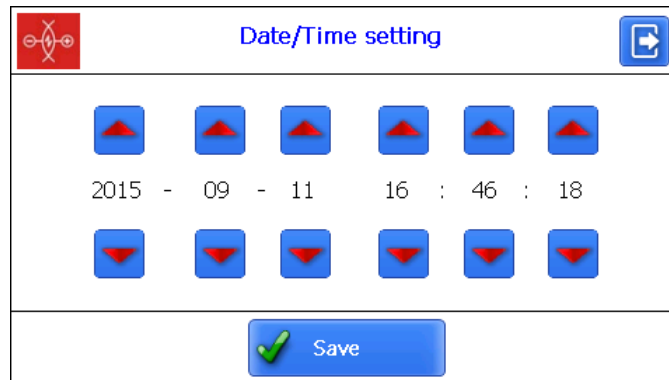
13.2. Units of measurement

All parameters as well as measurement results can be presented in the Metric system (millimeters), or in the English system of units (inches). To set the units of measurement, press the **Units** button. Next, select **Millimeters (mm)** or **Inches (in)**, and press **Save**.



13.3. Date/time setting

Press the **Date/Time** button and set the date and time by using the buttons  . Press the **Save** button.

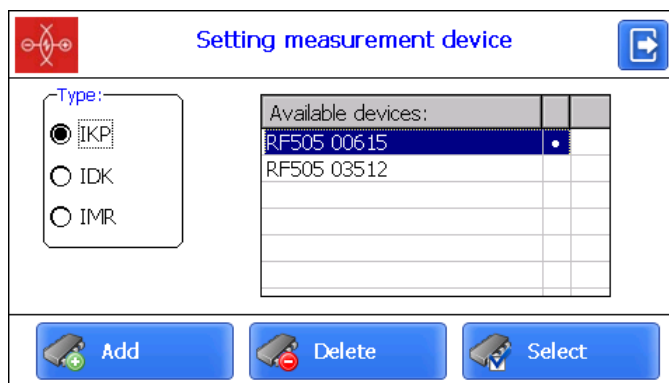


13.4. Device selection

The PDA Bluetooth-connection is automatically configured to work with the laser scanning module supplied with the PDA. Moreover, the PDA provides operation with other IKP scanning modules and measurement instruments for railway transport manufactured by RIFTEK (Wheel Diameter Measuring Gauge, IDK; Back-to-Back Distance Measuring Gauge, IMR).

To connect other devices, press the **Device type** button. The device selection window contains 3 types of devices available for connecting to PDA: IKP, IDK, IMR.

Each type of devices has a list of available devices (with which the connection has been established earlier, and which have been saved in the IKP memory).

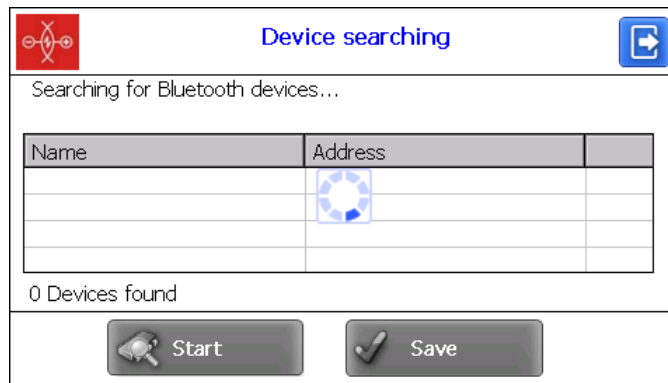


If the needed device is in the list, you can select it and press the **Select** button. The PDA will try to connect to the selected device.

To add a new device, press the **Add** button. The **Device searching** window will appear:



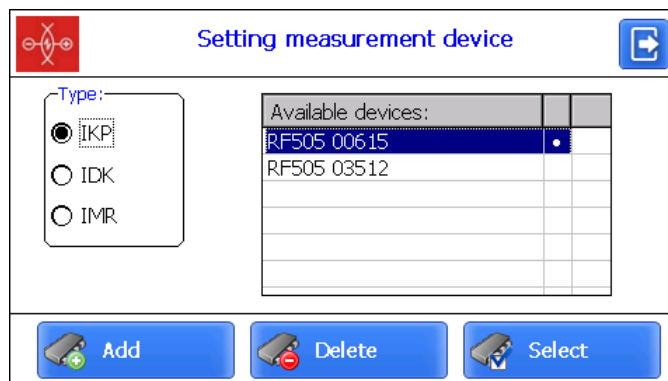
To search for devices, press **Start** and wait for the search to complete:



Detected devices (with their serial numbers) will appear on the screen:



Next, select the device and press the **Save** button to save the address of a new device.



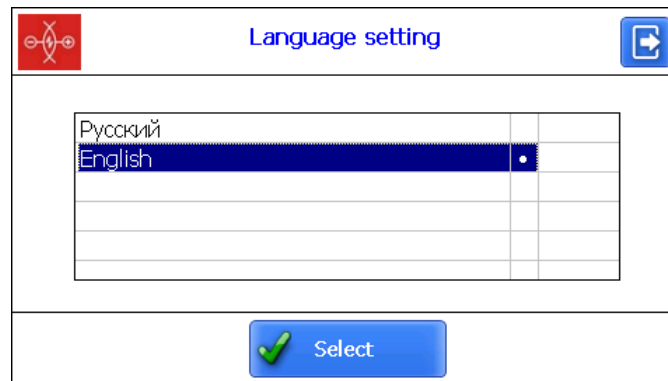
You can delete the device that you do not use anymore by pressing the **Delete** button.



13.5. Language setting

It is possible for the user to change the program language, form his own language support files as well as change/edit the terminology used.

To select the language, press the **Language** button. Next, select the required language support file and press the **Select** button.



If no such file is available, it is necessary to use the new files preparation procedure, which is described in par. [22.2.4.1.](#), and then load a new language file from PC to PDA as it is shown in par. [23.1.3.](#)

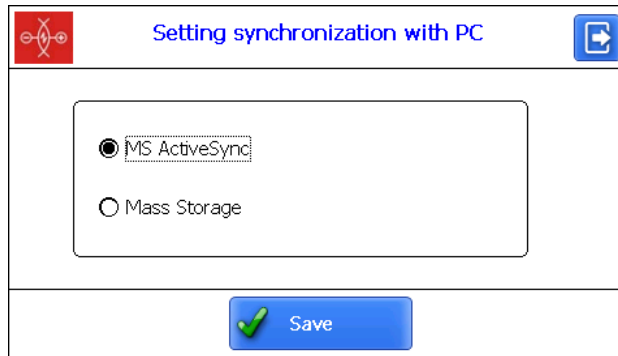
13.6. Synchronization with PC

To transfer data between PDA and PC, it is necessary to synchronize them. There are two ways of synchronization via USB cable.

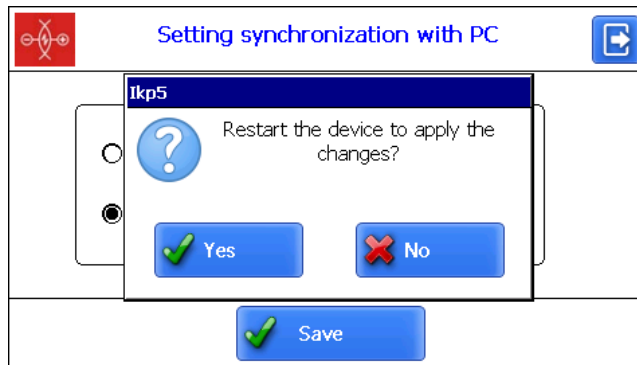
When you select **MS ActiveSync**, synchronization with PC is performed via the **ActiveSync** software (Windows XP), or via **Windows Mobile Device Center** (Windows 7).

When you select **Mass Storage**, the device is detected in Windows as an external storage device.

To select the type of synchronization, press the **Synchronization** button in the **Device** window. Next, select the required type and press **Save**.

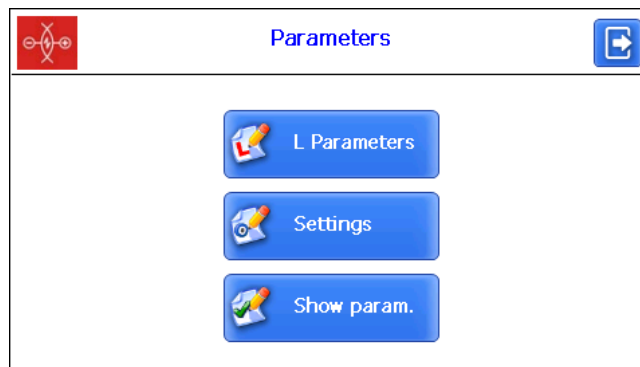


To apply the changes, PDA will prompt you to restart. If you do not need to sync the PDA with PC currently, you can restart the PDA later.



14. Measurement parameters setting

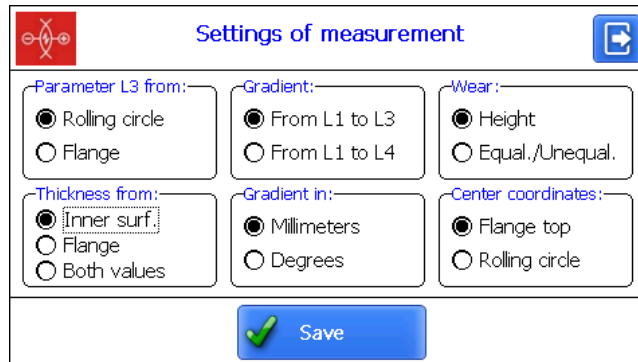
The **Parameters** window, which is called from the main program window, is intended for calculation settings of controlled parameters.



Button	Assignment
Settings	Calculation methods setting
Show param.	Selection of displayed parameters
L Parameters	L Parameters setting

14.1. Calculation methods setting

To select the calculation method, press the **Settings** button. The following window will appear:



Settings of measurement

Parameter L3 from:
 Rolling circle
 Flange


Gradient:
 From L1 to L3
 From L1 to L4

Wear:
 Height
 Equal./Unequal.

Thickness from:
 Inner surf.
 Flange
 Both values

Gradient in:
 Millimeters
 Degrees

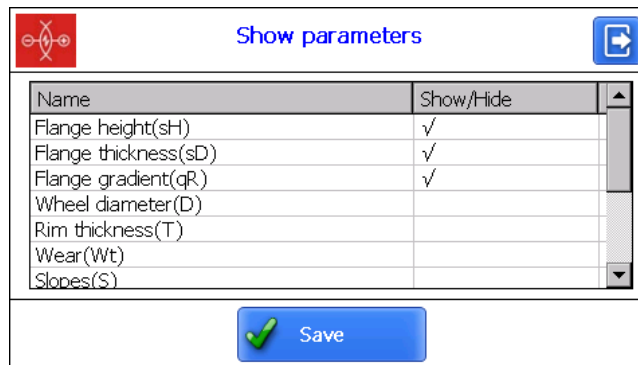
Center coordinates:
 Flange top
 Rolling circle



After selecting the required parameters, press the **Save** button to save changes.


14.2. Selection of displayed parameters

To enter the mode, press the **Show param.** button.



Show parameters

Name	Show/Hide
Flange height(sH)	√
Flange thickness(sD)	√
Flange gradient(qR)	√
Wheel diameter(D)	
Rim thickness(T)	
Wear(Wt)	
Slopes(S)	



To select/deselect the parameter to display, double-click in the **Show/Hide** column opposite to the required parameter. After selecting, you need to press **Save**.

14.3. L-parameters setting

To set L-parameters, press the **L Parameters** button.


In the table will be displayed only those parameters, which are necessary to calculate the selected geometrical parameters of the wheel.

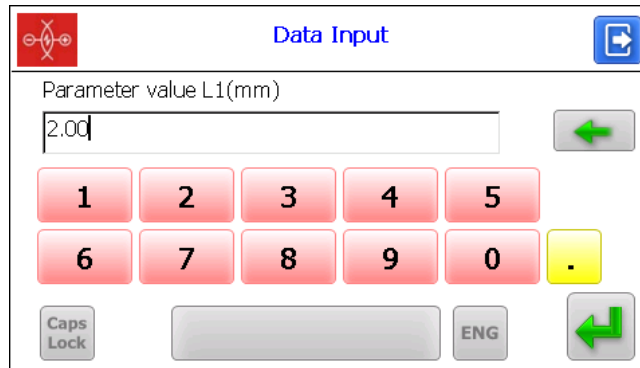


L-parameters

Code	Value		
L1	2.00	mm	
L2	70.00	mm	
L3	13.00	mm	
L15	15.00	mm	



To edit the parameters, double-click in the **Value** column opposite to the required parameter, and enter a new value in the **Data Input** window. Press the **Enter** button - .



When you have set all parameters, press the **Save** button to save them.

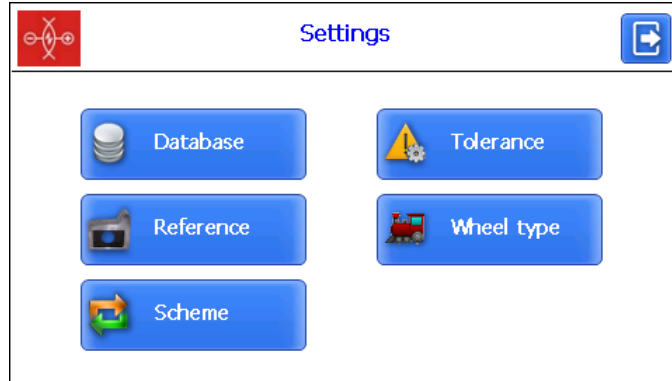
14.4. Preset parameters values

Values of L-parameters preset in the PDA are given in the Table:

L-parameter	Default value	Assignment
L1	2 mm	Used for calculation of the flange slope (qR)
L2	70 mm	Defines position of the wheel rolling circle, and used for calculation: - flange height (sH) - flange thickness (sD) - flange slope (qR) - inclination angle (A) - wheel diameter (D) - rim thickness (T) - wear (Wt, Wf, Wr)
L3	13 mm	Used for calculation: - flange thickness (sD) - flange slope (qR) - wear (Wf)
L4	13 mm	An additional point for calculation of the flange slope (qR)
L5	10 mm	Used for calculation of an angular wear (Wr)
L6	70 mm	Used for calculation of slope of the rolling surface section (S1)
L7	105 mm	Used for calculation of slope of the rolling surface section (S2)
L8	10 mm	Used for measurement of the profile inclination angle at the required point (A)
L9	140 mm	Used for inverting the measurement direction (L9 – profile width)
L10	599,35 mm	Used for calculation of the profile diameter (D)
L11	767 mm	Used for calculation of the reference profile rim thickness (T)
L12	140 mm	Used for calculation of the wheel width(L) and metall flow (sS)
L15	13 mm	Used for calculation of the flange thickness of tram wheels (sD15)
P7_1 P7_2 P8_1 P8_2	50 mm 105 mm 110 mm 130 mm	Used for calculation of the hollow (HI)
D1 D2	70 mm 107,5 mm	Used for calculation of the hollow (HI)

15. Setting the database parameters, tolerances and measurements schemes

The **Settings** window is intended to set the database parameters, tolerances, measurements schemes, etc.

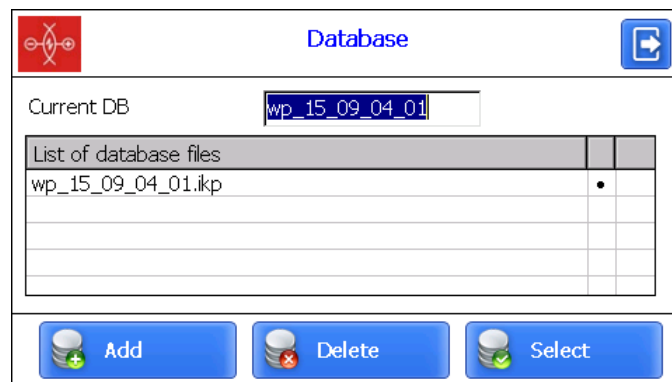


Button	Assignment
Database	Database selection
Reference	Reference profile selection
Scheme	Setting of measurement scheme
Tolerance	Setting of tolerances
Wheel type	Wheel type selection

15.1. Selection of the current database

You can save the measurement results to the PDA database when it is necessary. The program makes it possible to create and store several database files related to the date of measurement.

To select the database file, press the **Database** button.



To create a new database, press the **Add** button. The window for entering a name of a new database will appear.

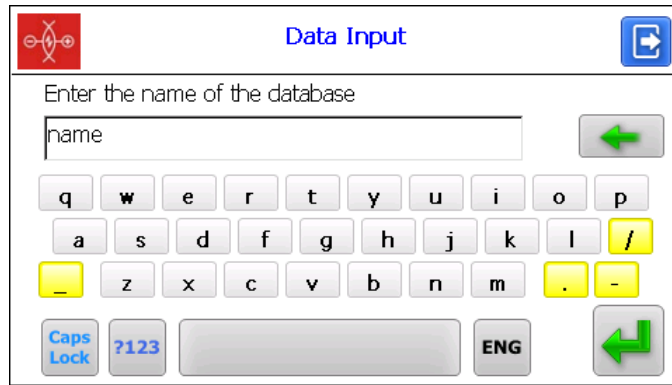
By default, it will be prompted to form the database file with the name **wp_yy_mm_dd.ikp**, where yy_mm_dd is the current date:

yy – the last two digits of the year;

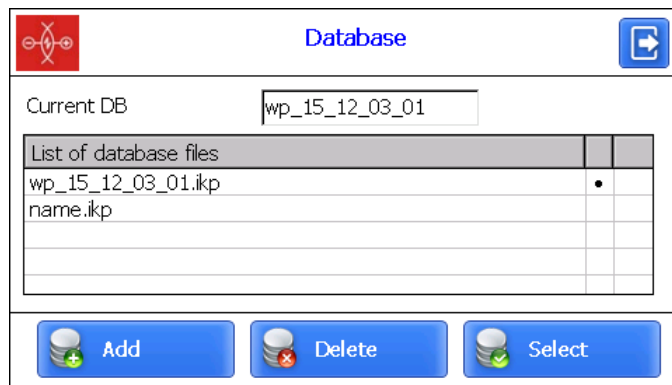
mm – month;

dd – day.

You can agree with this name, or enter another:



Press the **Enter** button -

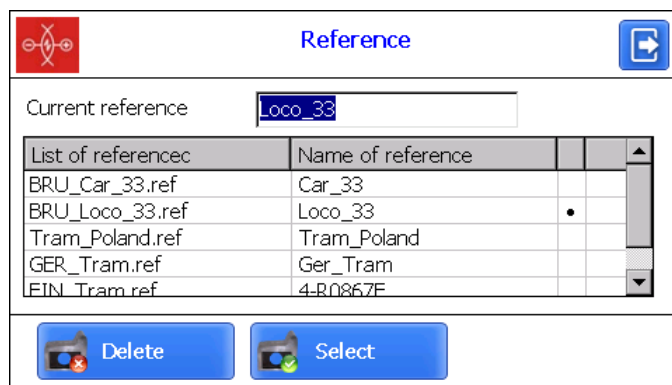


To select a database from a list, activate the line and press **Select**. The selected file will be marked with a "dot" symbol.

To delete the database file, activate the line and press **Delete**. If you delete the current database, the error message will appear.

15.2. Reference profile selection and installation

The program allows to compare the scanned profile of the wheel with the reference profile. To select the reference profile, press the **Reference** button.



To select the reference file, activate the line and press **Select**. The selected file will be marked with a "dot" symbol.

To delete the reference file, activate the line and press **Delete**. If you delete the current reference, the error message will appear.

15.2.1. Writing the reference profile to the database

Reference profiles are stored in the PDA database as profile description files with .ref extension. The PDA is supplied with several pre-installed profiles.

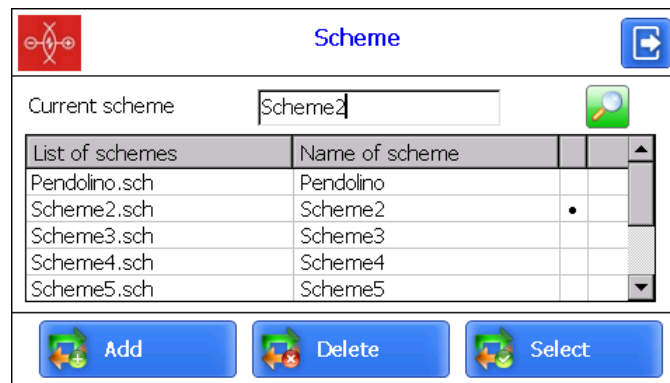
If there is no required reference profile in the database, the user can request the missing profile from **RIFTEK** (free service), and then transfer the received profile to the PDA as shown in Par. [23.1.4.](#)

15.3. Selection and formation of the measurement scheme

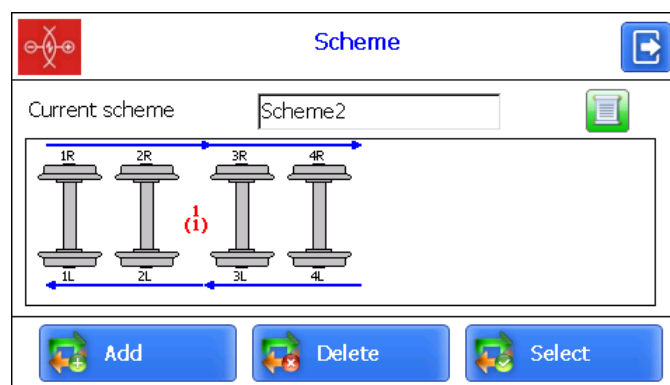
The measurement scheme is meant as a sequence of making measurements/processing of wheels in the rolling stock with specified parameters of each wheelset (wheelset numbers, car numbers, series, etc.). The program automatically offers the operator to perform measurement of the wheel in accordance with selected scheme of wheel processing. The program contains several preset schemes. Besides, the user can form his own measurement scheme.

15.3.1. Selection or removal of the measurement scheme

To select the measurement scheme file, press the **Scheme** button.



To view the scheme, you need to activate the line containing the scheme file name and to press the **View** button.




Arrows in the figure show direction of processing of wheel pairs as well as the names assigned to wheels (1L-first axis, left side; 2L-second axis, left side; 1R-first axis, right side, etc.).

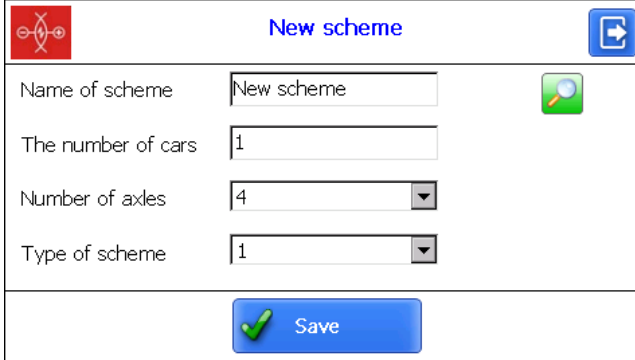
To select the scheme file, activate the respective line and press **Select**. The selected file will be marked with the symbol "•".

To delete the scheme file, activate the respective line and press **Delete**. If you delete the current scheme, the error message will appear.

15.3.2. Formation of a new measurement scheme

To form a new measurement scheme, press **Add**. The window for entering the measurement scheme name will appear.

Type the scheme name by using the on-screen keyboard. Then press the **Enter** button - .



Next:

- select the number of cars;
- select the number of axes;
- select the wheel processing scheme out of the options suggested;
- press **Save**.

You can look at the formed scheme by pressing the **View** button - .

This method of the measurement scheme formation allows to create only simple schemes without specifying the wheelset numbers, car numbers, series, etc. To form a complete scheme, see par. [29](#).

15.3.3. Loading of a new measurement scheme

If you can not create a new scheme as described in the previous paragraph, you can use the special program for PC (see par. [29](#)), and then upload that scheme to the PDA as described in par. [23.1.5](#).

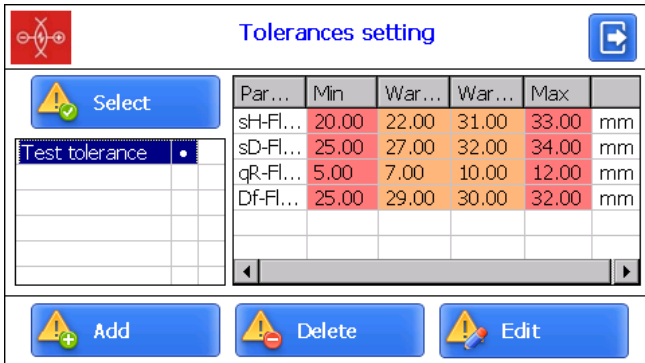
15.4. Setting of tolerances

The program automatically controls measured geometric parameters for going out beyond the tolerances set. It is possible for the user to create groups of tolerances. Control of parameters will be performed for a selected group.

To select the current group of tolerances, press the **Tolerance** button.

The table will show tolerances only for the selected geometric parameters of the wheel.

The red color indicates the maximum/minimum critical values of parameters. The orange color indicates the maximum/minimum values, which are close to critical values.



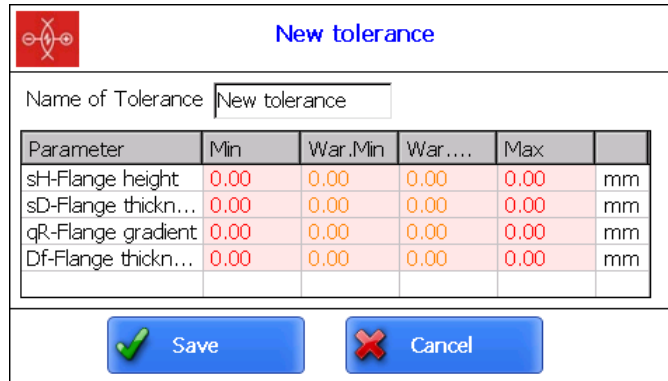
Par...	Min	War...	War...	Max	
sH-Fl...	20.00	22.00	31.00	33.00	mm
sD-Fl...	25.00	27.00	32.00	34.00	mm
qR-Fl...	5.00	7.00	10.00	12.00	mm
Df-Fl...	25.00	29.00	30.00	32.00	mm

To select the group of tolerances, activate the line and press **Select**. The selected file will be marked with a "dot" symbol.


To delete the tolerance, activate the line and press **Delete**. If you delete the current tolerance, the error message will appear.

To edit the tolerance, activate the line and press **Edit**.

To add a new tolerance, activate the line with the type name and press **Add**. You will see on the screen:



Parameter	Min	War.Min	War....	Max	
sH-Flange height	0.00	0.00	0.00	0.00	mm
sD-Flange thickn...	0.00	0.00	0.00	0.00	mm
qR-Flange gradient	0.00	0.00	0.00	0.00	mm
Df-Flange thickn...	0.00	0.00	0.00	0.00	mm

To change the type name, it is necessary to set cursor in the **Name of Tolerance** field, and to enter a new value in the appeared window. Then press the **Enter** button - .

To edit the value, it is necessary to double-click on the **Min/Max/War.Min/War.Max** column opposite to the specific parameter, and to enter a new value in the emerged window. Then press the **Enter** button. If any parameter has a zero value, the tolerance will not be used.

To save changes, press **Save**.

15.5. Wheel type selection and installation

If several wheels types are used, it is possible to set definite measurement scheme, reference profile and L-parameters for every wheel type

For example, we have three types of wheels: WheelType1, WheelType2, WheelType3. Every time for a new wheel type we can measure L-parameters, scheme, reference and tolerances, or we can define these values for every wheel type, and select only the required type.

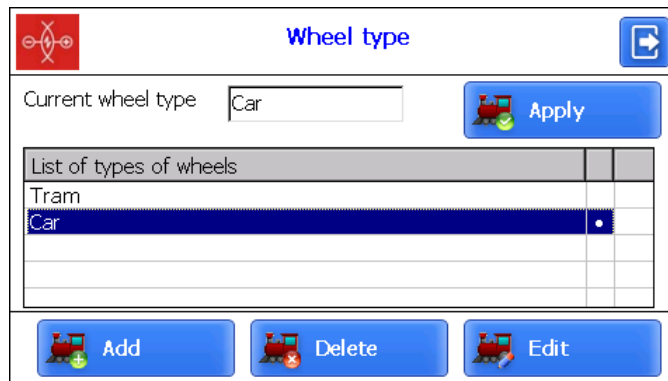
Example

WheelType 1: Reference 1, Scheme 1, Tolerance 1, L-Parameters 1;

WheelType 2: Reference 2, Scheme 2, Tolerance 2, L-Parameters 2;

WheelType 3: Reference 3, Scheme 3, Tolerance 3, L-Parameters 3;

To select the wheel type, press the **Wheel type** button.



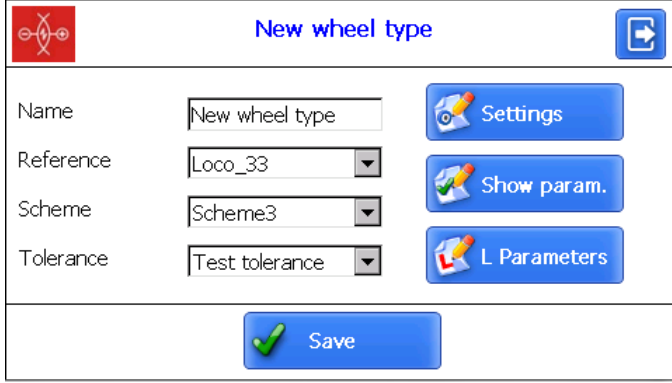
List of types of wheels	
Tram	
Car	•


To select the wheel type, activate the respective line and press **Apply**. The selected file will be marked with the symbol "•".

To delete the wheel type, activate the respective line and press **Delete**. If you delete the current type, the error message will appear.

To edit the wheel type, activate the respective line and press **Edit**.

To add a new wheel type, activate the line with the type name and press **Add**. View on the screen:



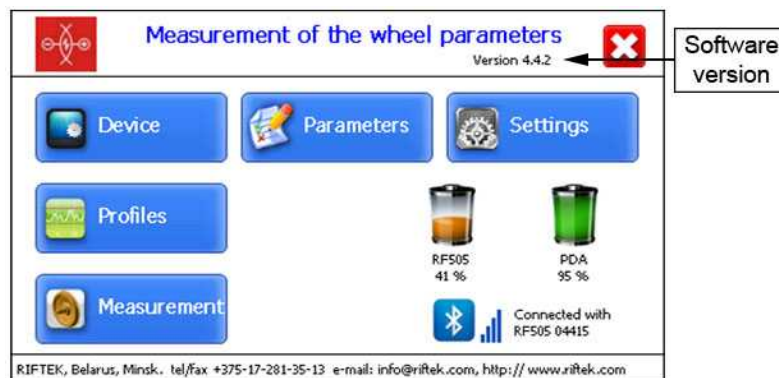
To change the type name, it is necessary to set cursor in the **Name** field, and to enter a new value in the appeared window. Then press the **Enter** button - .

Next:

- select the reference profile (**Reference**);
- select the scheme (**Scheme**);
- select the tolerance (**Tolerance**);
- set Settings (**Settings** button, see par. [14.1.](#));
- set the displayed parameters (**Show param.** button, see par. [14.2.](#));
- set L-parameters (**L Parameters** button, see par. [14.3.](#));
- press **Save**.

16. Updating of PDA software

You can view the software version in the main program window:




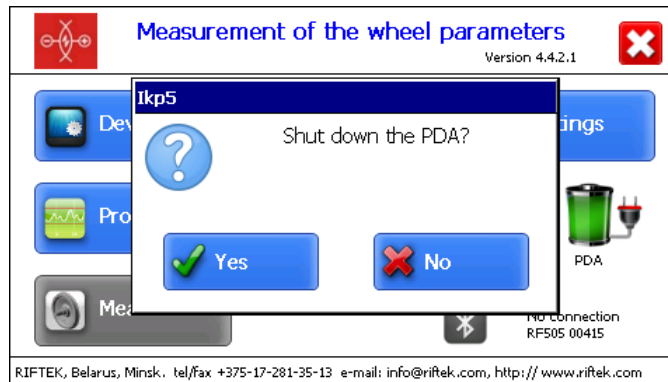
The latest software version can be downloaded from the website:

www.riftek.com/media/documents/ikp/lkp5_PDA_Software.zip

Procedure of PDA software updating is described in par. [23.1.6.](#) of this manual.

17. Shutdown

To shutdown the PDA, press the **Shutdown** button - .



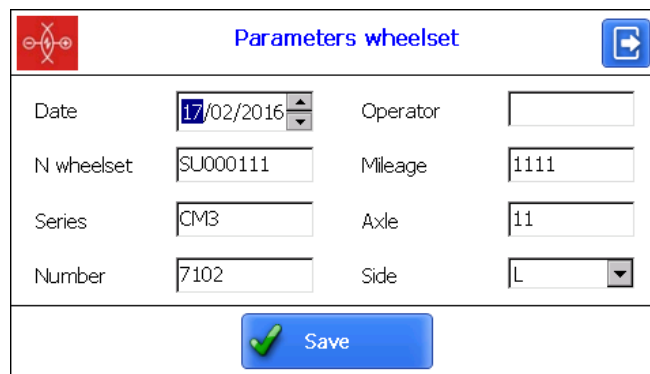
18. Measurements with database maintenance

There are two types of measurements:

1. Rapid measurements without saving the results.
 2. Measurements by using the selected scheme with saving results to the database.
- Procedure of rapid measurements is described in par. [12](#). How to select the measurement type, see par. [12.2](#).

The second type is used for a fully functional work with the profilometer with maintenance of the measurements database.

When Bluetooth-connection is established, you can start to measure by pressing the **Measurement** button in the main program window. The window of wheelset parameters will appear on the screen:

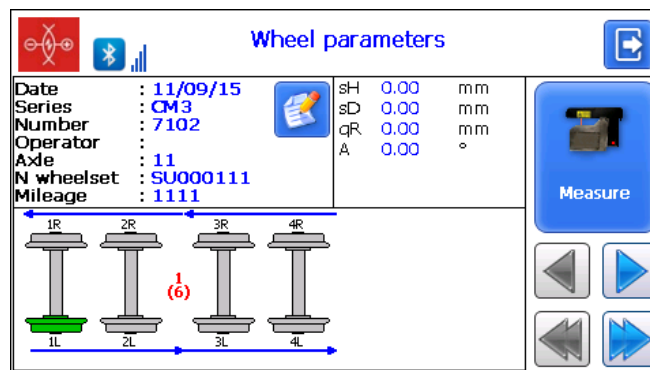


The screenshot shows a form titled "Parameters wheelset". It contains several input fields arranged in two columns:

- Date: 17/02/2016
- Operator: (empty)
- N wheelset: SU000111
- Mileage: 1111
- Series: CM3
- Axle: 11
- Number: 7102
- Side: L

At the bottom of the form is a blue "Save" button with a green checkmark icon.

Parameters fields will be filled in accordance with the selected measurement scheme. If needed, you can fill/edit the required fields, and press the **Save** button to save changes. The selected scheme will be displayed on the screen:

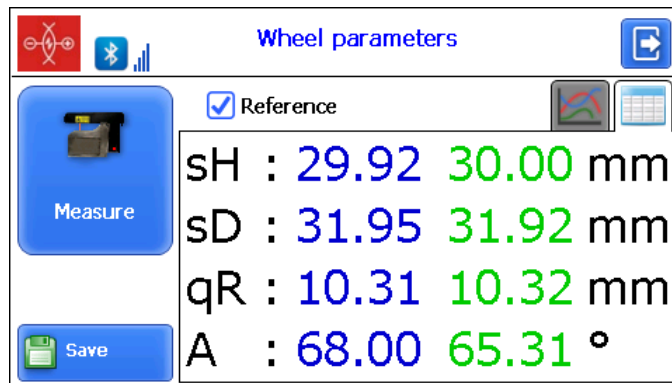


Designations and buttons:

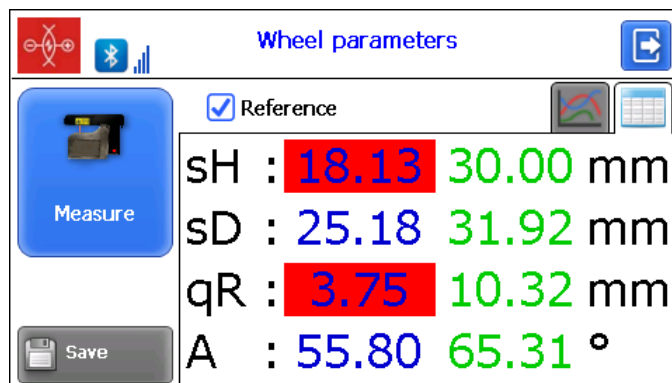
	an ordinal number of the car to be measured (number of cars in the rolling stock)
	edit the wheelset parameters
	pass to the previous/next wheel
	pass to the previous/next car
	a measured wheel
	a wheel to be measured the next time
	a non-measured wheel
	a measured wheel to be measured again
	measurement

18.1. Measurement

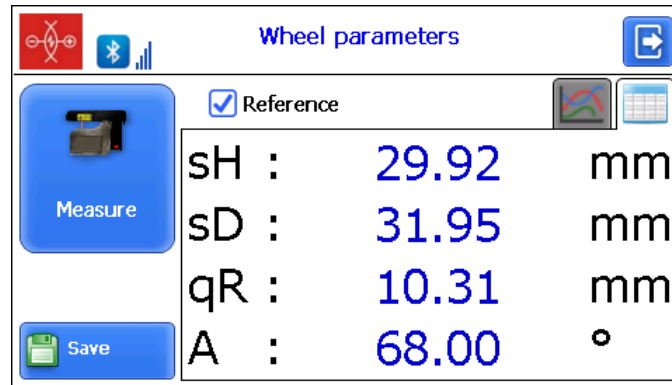
- Press the **Measure** button in order to measure the wheel offered by the program (highlighted in green). The laser module will scan the wheel surface.
- Upon completion of the scanning process, the PDA will show the values of selected geometrical parameters.




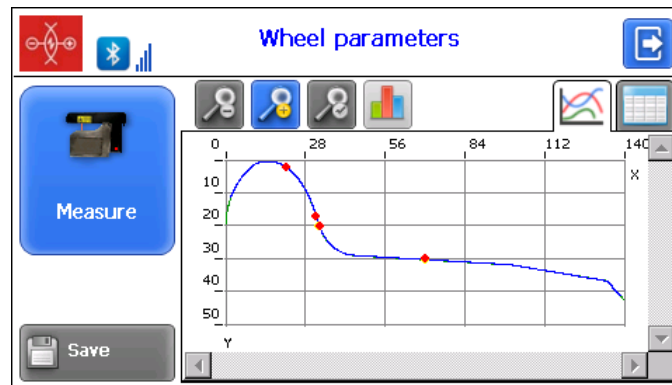
When the value is beyond the tolerances, it will be highlighted in red:



The program allows to display only parameters of the measured profile. To hide the reference values, you need to untick the **Reference** box.

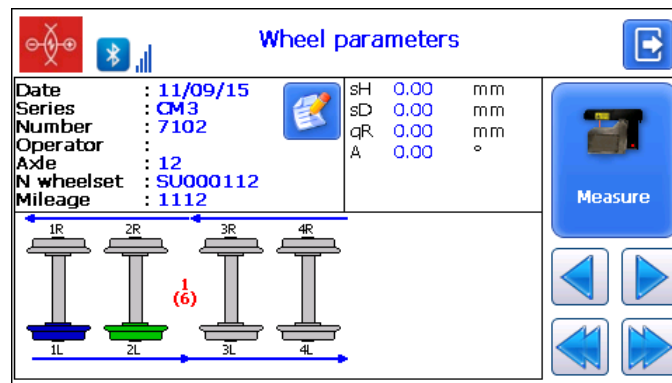


- To view the wheel profile, press the **View** button - . The scanned wheel profile and the selected reference profile will be displayed on the PDA screen.

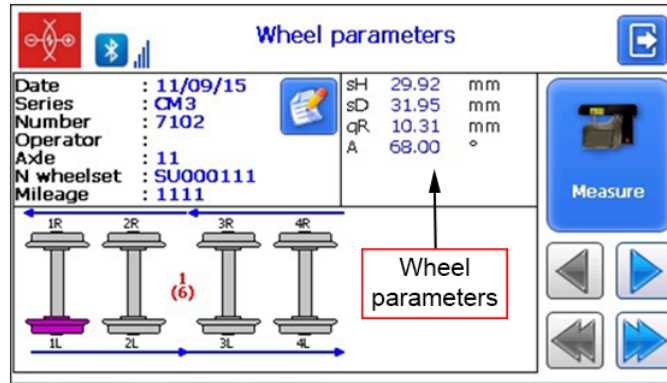


For more information, see par. [20.2](#).

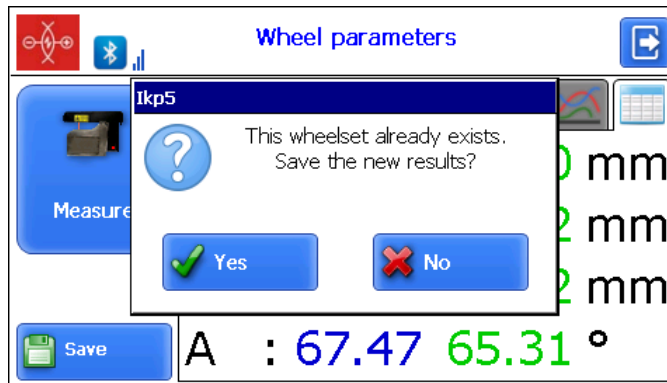
- To repeat the measurement, press the **Measure** button.
- When a satisfactory result is obtained, press the **Save** button to save it.
- The program will offer to pass to the measurement of the next wheel in accordance with the selected scheme of measurement.



- To view the results of previous measurements, you can use the arrows. If you select the measured wheel, the saved wheel parameters will be displayed on the PDA screen.

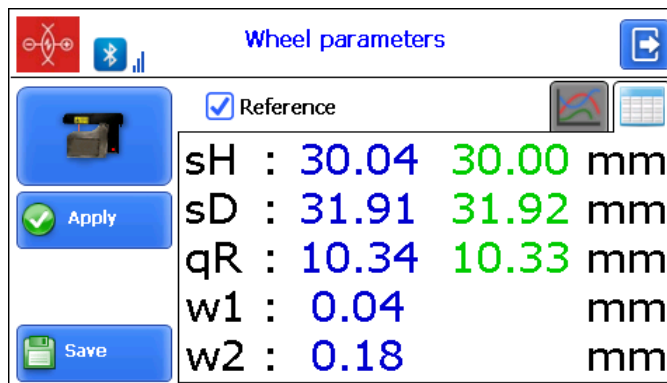


- When you measure the wheel that was already measured, the program prompts you to replace the existing database file with the new one.

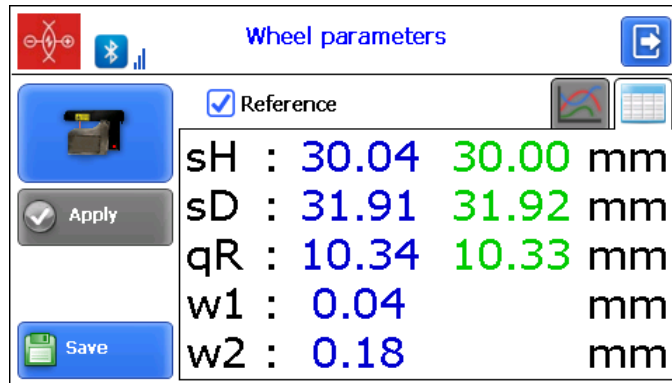


18.2. Measurement of even/uneven wear

Measurement of an even/uneven wear is slightly different from a standard measurement. To obtain the result of the wear, it is necessary to perform several measurements at different points of the wheel. When passing to the measurement window, an additional button **Accept** will appear on the screen.



After each performed measurement, you need to press **Accept** to save current values of the wear. At subsequent measurements the program will automatically find the maximum and minimum wear of the wheel and calculate an even/uneven wear.



When a satisfactory result is obtained, press the **Save** button to save it.

18.3. Measurement of defects

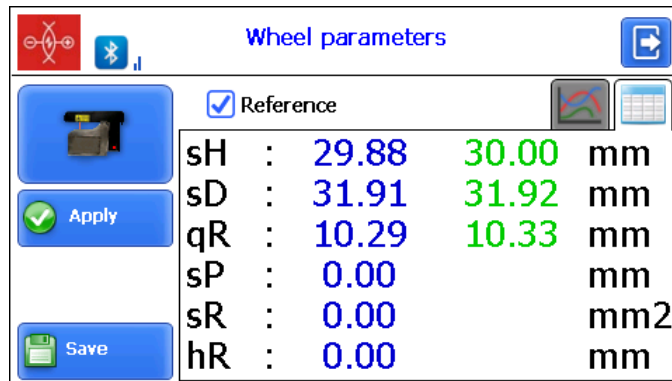
IKP allows to measure defects of wheelsets.

- Slide size (sP)
- Cavity size (hR)
- Cavity area (sR)

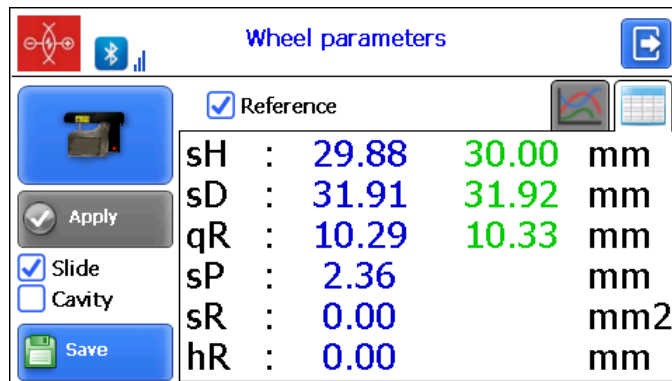
Measurement of defects differs from the standard measurement.

The procedure of measuring the slide (cavity) is described below:

- Perform the measurement at the profile point that do not have any defects (slides, cavities), which can be detected visually.



- If you obtained a satisfactory result, press the **Apply** button. The checkboxes **Slide** and **Cavity** will appear on the screen.



- Select the defect that you need to measure (tick the required checkbox).
- Place the profilometer properly (a laser beam must pass through the measured defect).
- Press the **Measure** button to start the measurement.

Upon completion of the measurement, the program calculates the value of selected parameter.

When a satisfactory result is obtained, press **Save** to save data to database.

19. Measuring by IKP, IDK, IMR, and saving to database

How to use the PDA with other devices is described in the corresponding User's Manuals.

It is often needed that the measurement results obtained from different devices were stored in one database. In this case, all entered parameters of the specific wheelset must be the same in all devices.

These parameters are:

- Date
- N wheelset
- Series
- Number
- Axle
- Side (besides IMR)




20. Browsing the database

To browse the saved data, press the **Profiles** button in the main window. The PDA screen will display information about the current database, quantity of saved profiles, table with saved profiles, and measured values of selected parameters.

Date	Series	Number	Axle	R/L	N wheels	Measured	Reference	
06/01/16	CM3	7102	11	L	SU0001	sH 29.87	30.00	mm
06/01/16	CM3	7102	12	L	SU0001	sD 31.89	31.92	mm
06/01/16	CM3	7102	13	L	SU0001	qR 10.33	10.33	mm
06/01/16	CM3	7102	14	L	SU0001			
06/01/16	CM3	7102	14	R	SU0001			
06/01/16	CM3	7102	13	R	SU0001			
06/01/16	CM3	7102	12	R	SU0001			

Buttons:

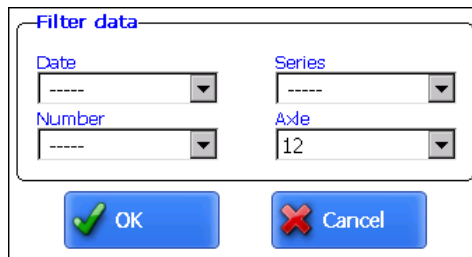
	Browse the profile of selected wheel
	Delete the selected wheel

	Add a filter
	Delete a filter
	Save the reference file

20.1. Data filtering

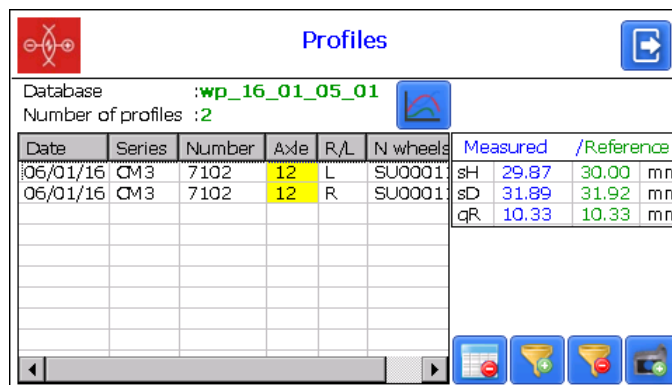
To add a filter, you need to press the **Filter** button, and to set filter parameters in the appeared window.

An example of filtering by the **Axle** parameter:



The dialog box titled "Filter data" contains four dropdown menus: Date, Series, Number, and Axle. The "Axle" dropdown is set to "12". At the bottom are "OK" and "Cancel" buttons.

The filtered field will be highlighted in yellow:




The "Profiles" window shows a table with the following data:

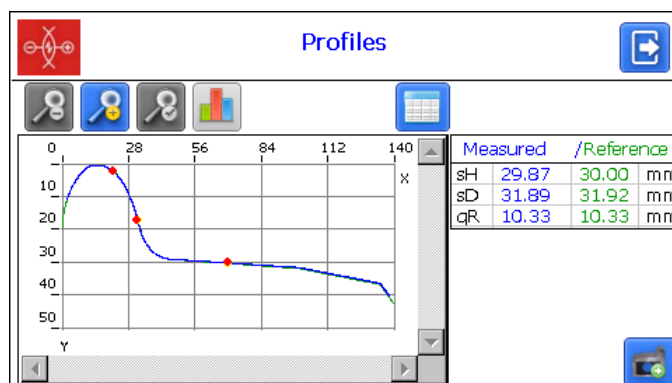
Date	Series	Number	Axle	R/L	N wheels	Measured	/Reference
06/01/16	CM3	7102	12	L	SU0001	sH 29.87	30.00 mm
06/01/16	CM3	7102	12	R	SU0001	sD 31.89	31.92 mm
						qR 10.33	10.33 mm

The "Axle" column is highlighted in yellow.

To delete the current filter, you need to press .

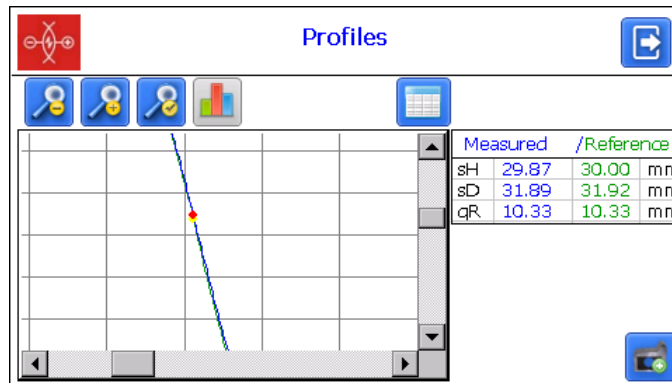
20.2. Visualization of the wheel profile

To browse the wheel profile, you need to press the **Profile** button - . The scanned wheel profile and the profile of selected reference will be displayed on the PDA screen.



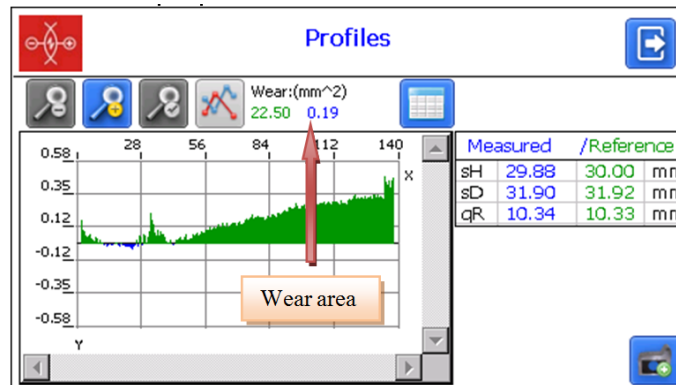
	Zoom in
	Zoom out
	Standard image scale
	Browse the profile wear

An example of a zoomed image:



An example of visualizing the profile wear.

Information about the wear area is displayed on the screen. A positive wear area is highlighted in green, a negative one - in blue.



21. Installation of software on PC and startup

21.1. Installation of database support software

The **ikp5_DB** software is intended for maintaining wheel sets wear database on a personal computer (the updated version of the program can be downloaded from www.riftek.com/media/documents/ikp/ikp5_PC_Software.zip).

To install the software, insert a compact disk to the PC CD drive, select and start the **Install_ikp5.exe** file in the **Software** folder. Follow guidelines of the installation wizard. By default, the software will be installed in the following directory **C:\Program Files (x86) \Riftek, LLC\ikp5_db**.

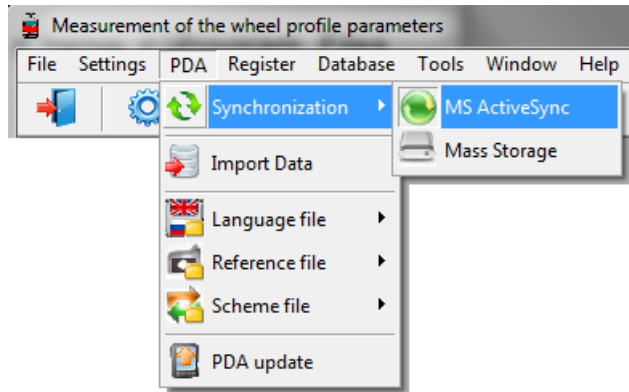
21.2. Synchronization of PDA and PC

There are two ways of synchronization via USB cable to transfer data between PDA and PC:

- MS ActiveSync
- Mass Storage

When you select **MS ActiveSync**, synchronization with PC is performed via the **ActiveSync** software (Windows XP), or via **Windows Mobile Device Center** (Windows 7), which must be installed on PC.

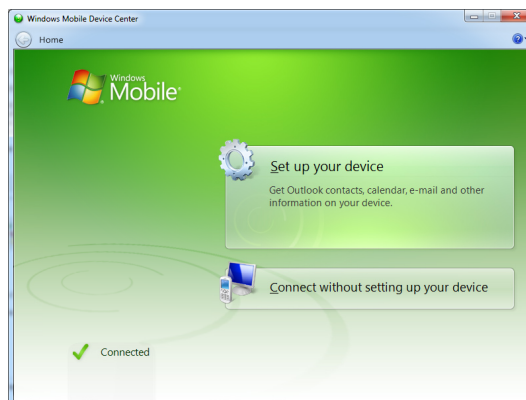
It is necessary to select **MS ActiveSync** as the synchronization type (see par. [13.6.](#)).



When you select **Mass Storage**, the device will be detected in Windows as an external storage device.

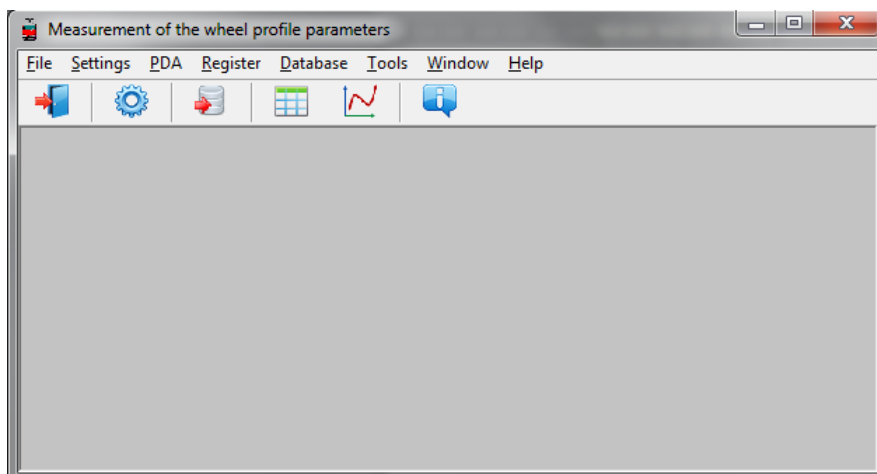
It is necessary to select **Mass Storage** as the synchronization type (see par. [13.6.](#)).

To check if the **MS ActiveSync** synchronization is correct, switch on the PDA and connect it to the USB port of the PC by the supplied cable. If the connection is successful, a message about it will appear on the screen:




21.3. Program startup

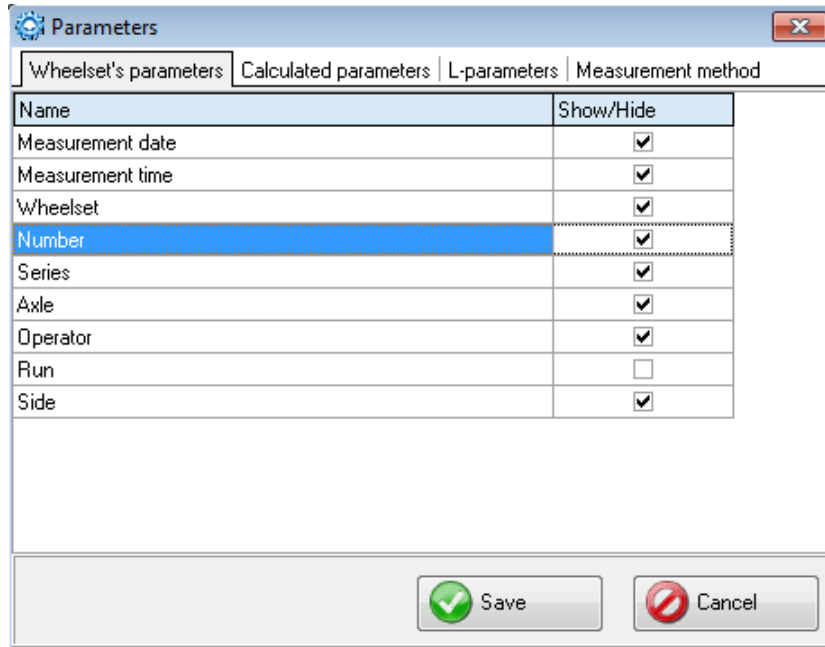
To start the program, click **Start > All programs > Riftek, LLC > IKP5_DB > Ikp5_DB.exe**. View of the main program window is shown below.



22. User settings of the program

22.1. Parameters setting

To go to the window of parameters setting, click **Settings > Parameters** in the main window, or click .

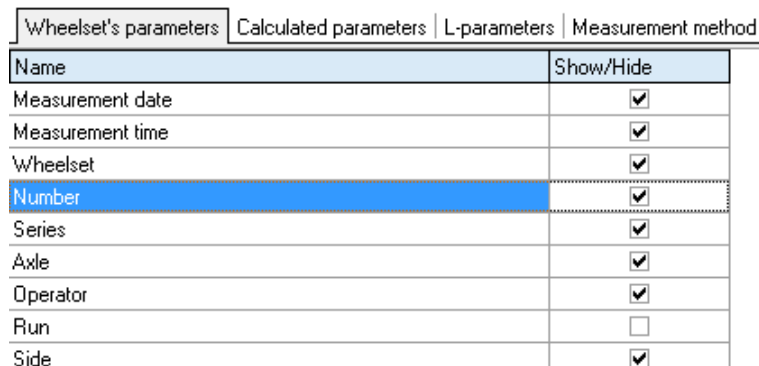


The window of parameters contains 4 tabs:

- Wheelset's parameters
- Calculated parameters
- L parameters
- Measurement method

22.1.1. "Wheelset's parameters" tab

This tab is intended to select parameters, which will be displayed on the screen when viewing the database.



Name	Show/Hide
Measurement date	<input checked="" type="checkbox"/>
Measurement time	<input checked="" type="checkbox"/>
Wheelset	<input checked="" type="checkbox"/>
Number	<input checked="" type="checkbox"/>
Series	<input checked="" type="checkbox"/>
Axle	<input checked="" type="checkbox"/>
Operator	<input checked="" type="checkbox"/>
Run	<input type="checkbox"/>
Side	<input checked="" type="checkbox"/>

If the parameter is ticked, its value will be shown in the table of results and in the table of profiles.

22.1.2. "Calculated parameters" tab

This tab is intended to select the wheelset geometrical parameters, which will be calculated and displayed on the screen when viewing the database.

Wheelset's parameters Calculated parameters L-parameters Measurement method	
Name	Show/Hide
Height (sH)	<input checked="" type="checkbox"/>
Thickness (sD)	<input checked="" type="checkbox"/>
Thickness (sD1)	<input checked="" type="checkbox"/>
Parameter (sF)	<input checked="" type="checkbox"/>
Gradient (qR)	<input checked="" type="checkbox"/>
Diameter (D)	<input checked="" type="checkbox"/>
Tire (T)	<input type="checkbox"/>
Slope (SI)	<input type="checkbox"/>
Angle (A)	<input type="checkbox"/>
Hollow (HI)	<input type="checkbox"/>
Rim width (L)	<input type="checkbox"/>
Wear (Wt)	<input type="checkbox"/>
Back-to-Back distance (M)	<input type="checkbox"/>
Multiple measurements (M)	<input type="checkbox"/>

Description and functions of parameters are the same as in the PDA software (see par. [10.](#)).

22.1.3. "L-parameters" tab

This tab is intended to set the values of reference points for calculated geometrical parameters of the wheelset.

Wheelset's parameters Calculated parameters L-parameters Measurement method		
Code	Value	
Parameter L1	2,00	mm
Parameter L2	70,00	mm
Parameter L3	13,00	mm
Parameter L10	14975,00	mm
Parameter L15	15,00	mm

Description and functions of the reference points are the same as in the PDA software (see par. [10.](#)).

22.1.4. "Measurement method" tab

This tab is intended to select the calculation method.

Wheelset's parameters Calculated parameters L-parameters Measurement method	
Parameter L3 from: <input checked="" type="radio"/> Rolling circle <input type="radio"/> Flange	Thickness from: <input checked="" type="radio"/> Inner surf. <input type="radio"/> Flange <input type="radio"/> Both values
Gradient: <input checked="" type="radio"/> From L1 to L3 <input type="radio"/> From L1 to L4	Wear: <input checked="" type="radio"/> Height <input type="radio"/> Equal./Unequal
Gradient in: <input checked="" type="radio"/> Millimeters <input type="radio"/> Degrees <input type="radio"/> Accept./Unaccept.	Coordinates center: <input checked="" type="radio"/> Flange top <input type="radio"/> Rolling circle
Units measure <input checked="" type="radio"/> mm <input type="radio"/> inch	Inverted profile <input checked="" type="radio"/> No <input type="radio"/> Yes

Description and functions of the measurement methods are the same as in the PDA software (see par. [10.](#)).

22.1.4.1. Selection of measurement units

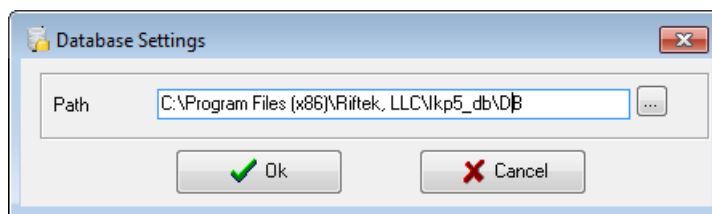
All parameters and measurement results can be in the Metric system (millimeters), or in the English system (inches).

To set the units of measurement, you need to select **mm** or **inches** in the **Units of measurement** field. After saving the changes, all information will be displayed in the selected units of measurement.

22.2. Database settings

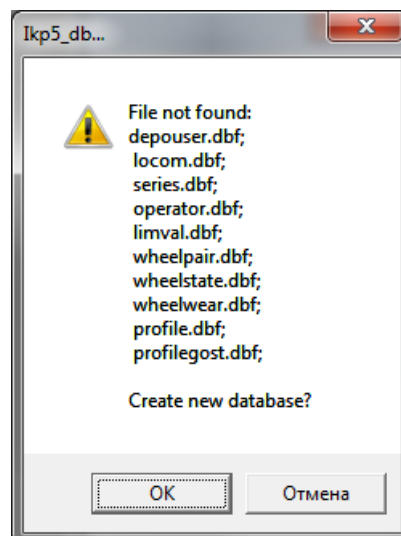
22.2.1. Setting the path to database

It is possible for the user to change the drive and the directory of the profiles database storage. In the main window, select **File > Path to DB...**

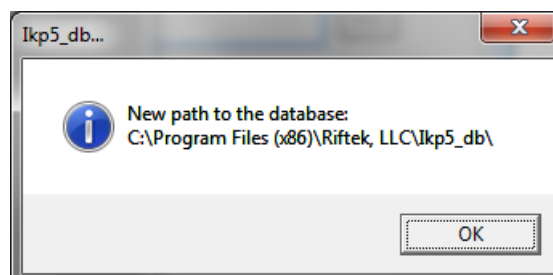


Next:

- click **Ok**
- specify a new path to the database
- confirm the creation of a new database

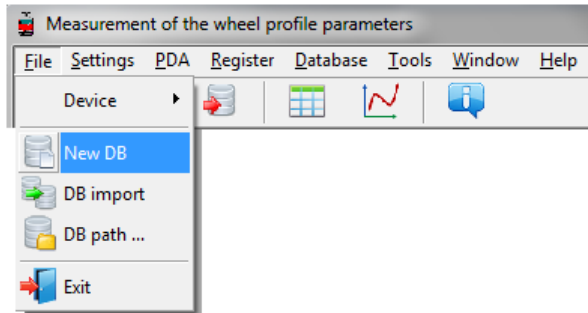


All database files will be copied to the specified path.



22.2.2. Creation of empty database

To create an empty database, select **File > New DB**.

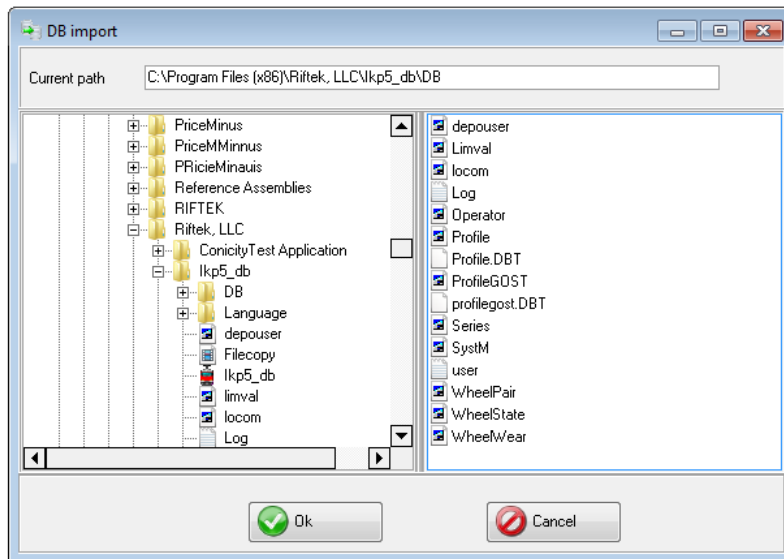


All data except the reference files will be deleted from the database. At the same time, the **DB(dd.mm.yy)** directory will be created in the installation directory where to all the deleted data will be copied (**dd.mm.yy** – current date). If necessary, these data can be restored (see par. [22.2.3](#)).

22.2.3. Import of database

To import data to the database from the other database, you need to:

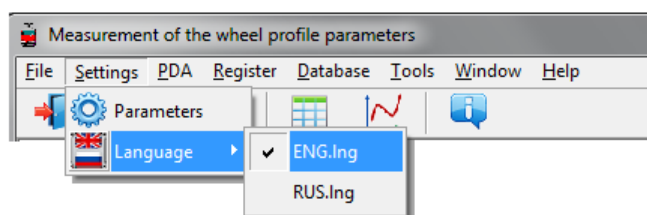
- Select **File > Import Data**.
- Select the directory with DB files in the left window. All files will appear in the right window:



- Click **OK** to import data.

22.2.4. Selection of software language

To change the software language, select **Settings > Language** and select the required language support file.



22.2.4.1. Preparation and installation of the language support file

The user can change the language, form his own language support files as well as change/edit the terminology used. Language support files are located in the directory used in the process of installation. By default, the following directory is used: **C:\Program Files (x86)\Riftek, LLC\lcp5_db\Language**.

The directory contains two files, **RUS.Ing** and **ENG.Ing**, to support Russian and English languages respectively.

To create the support file for any other language, it is necessary to:

- copy one of the existing files, for example - **ENG.Ing**, under the other name, for example - **DEU.Ing**;
- edit the renamed file by using any text processor, namely, change all terms and phrases to analogous ones from the required language;
- save the edited ***.Ing** file in the **Language** directory.

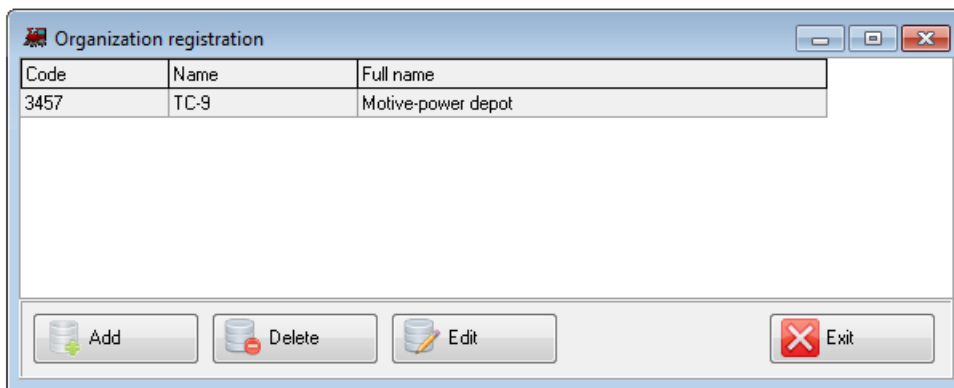
To change and edit terminology, it is necessary to:

- edit the corresponding language file by using any text processor;
- save the edited ***.Ing** file in the **Language** directory.





22.3. Registration data

22.3.1. Selection of the organization

To add/chose the user organization, select **Registration > Organization**. Subsequently, this information will be used in automatic generation of reports.



Buttons:

	Add a new organization
	Delete the selected organization
	Edit the selected organization
	Exit the mode

To select a current organization:

- Click **Edit**
- Tick the depot
- Click **Save**

Organization

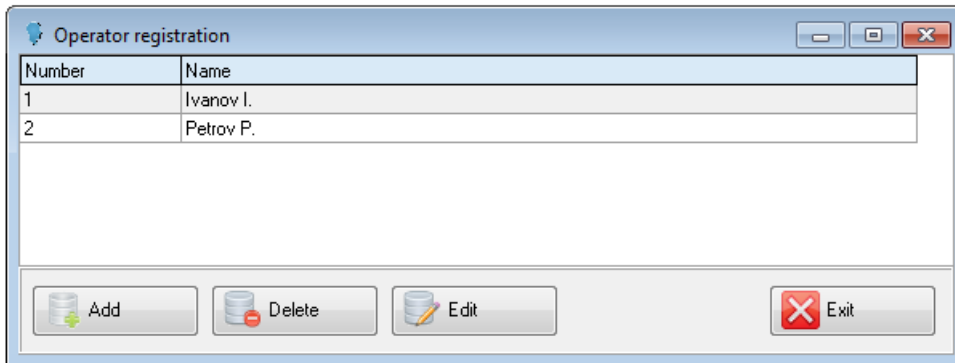
Code

Name

Full name

22.3.2. Registration of operators

Steps to follow: **Registration > Operator**. Operators data are used for identifying operators by **Number**.



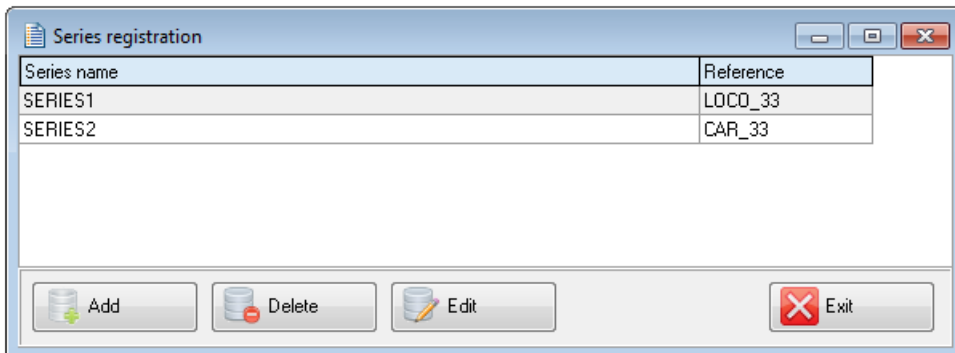
Operator registration

Number	Name
1	Ivanov I.
2	Petrov P.

Functions of buttons are similar to those in par. [22.3.1.](#)

22.3.3. Registration of series

Steps to follow: menu **Registration > Series**. Registered series of cars or locomotives are displayed in the emerged window.



Series registration

Series name	Reference
SERIES1	LOCO_33
SERIES2	CAR_33

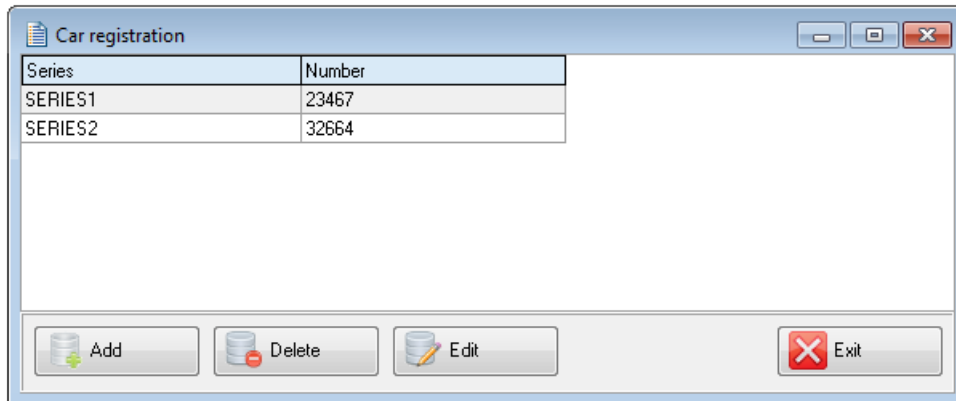
When registering a new series, a new entry for this series will be added in the table of tolerances automatically (see par. [22.3.5.](#)).

Functions of buttons are similar to those in par. [22.3.1.](#)

When adding a new series, it is necessary to enter the name of the series and to select the reference profile for it. Flange parameters of the selected profile will be calculated and added to the table of tolerances automatically after saving the series (see par. [22.3.6.](#)).

22.3.4. Registration of car/locomotive numbers

Steps to follow: menu **Registration** > **Number**. Registered numbers of cars/locomotives are displayed in the emerged window.



Functions of buttons are similar to those in par. [22.3.1.](#)

22.3.5. Registration of tolerances

Steps to follow: menu **Registration** > **Tolerance**. Registered series of cars/locomotives with boundary values of calculated geometric parameters of the wheelset are displayed in the emerged window.



Series	Parameter	Norm	Min	Alert min	Alert max	Max	
SERIES1	Height sH	23,67	26,00	27,00	31,00	32,00	mm
SERIES2	Thickness sD	24,31	23,00	26,00	32,00	34,00	mm
	Gradient qR	2,94	5,00	6,00	11,00	12,00	mm
	Diameter D	0,00	0,00	0,00	0,00	0,00	mm
	Thickness sDF	19,61	25,00	27,00	32,00	33,00	mm

Only parameters, which were selected in the list of parameters, are available for editing (see par. [22.1.2.](#)).

Maximum/minimum critical values of parameters are indicated with a red color. An orange color indicates maximum/minimum values of parameters, which are close to critical.

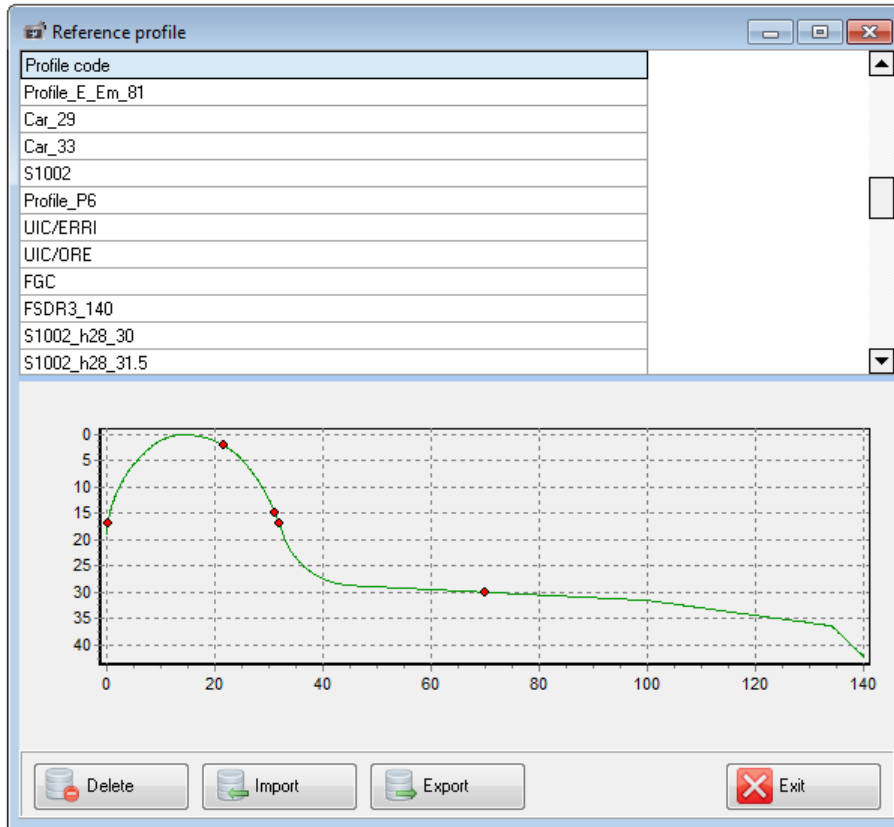
The **Norm** value is calculated and added to the table automatically when adding/editing the series of the selected reference (see par. [22.3.3.](#)).

22.3.6. Registration of reference profiles

The program comes with several preset profiles. In addition, the supplied disc with software contains the base of reference profiles. Profiles are in the **Reference Profiles** directory and divided into separate directories for each country.




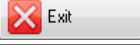
In addition, the user can form a description of the required profile himself or request it from **RIFTEK** (free service).

To browse available profiles, select **Registration** > **Reference**:



The window of profiles displays the table with the list of reference profiles, saved to database, and a graphical view of the selected profile.

Buttons:

	Delete the reference profile
	Import the reference profile from *.ref file
	Export the reference profile to *.ref file
	Exit the mode

22.3.6.1. Request and registration of the profile file

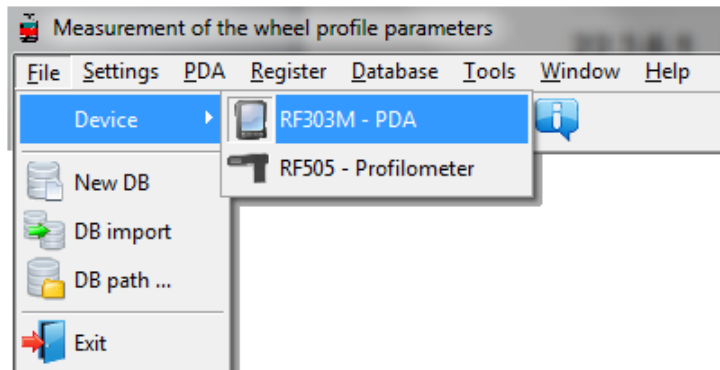
To get .ref file of reference profile send the drawing of profile to **RIFTEK** (info@riftek.com). Register the received .ref file as follows:

- click **Import**
- in the window appeared indicate the way to the .ref-file
- click **Open**

The profile will be added to the base of reference profiles.

23. Data exchange between PDA and PC

To exchange data between PC and PDA, you need to select the device: **File > Device > RF303M-PDA**.



Data exchange between PC and PDA is performed by means of direct cable connection of PDA to PC USB-port (special **RF505.42** cable is supplied).

There are two ways of synchronization via USB cable:

- ActiveSync
- Mass Storage

For more details see par. [21.2](#).

23.1. ActiveSync synchronization

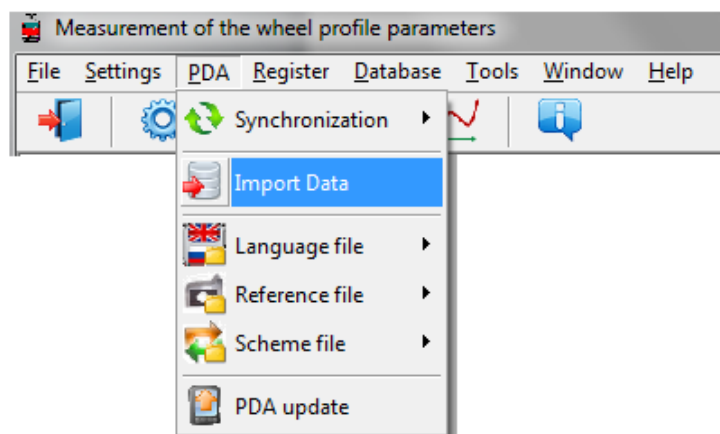
When you select this type of synchronization, additional features of data exchange with PDA will be available:

- Transfer of database files to PC
- Transfer of language files
- Transfer of reference profile files
- Transfer of processing scheme files
- PDA software update

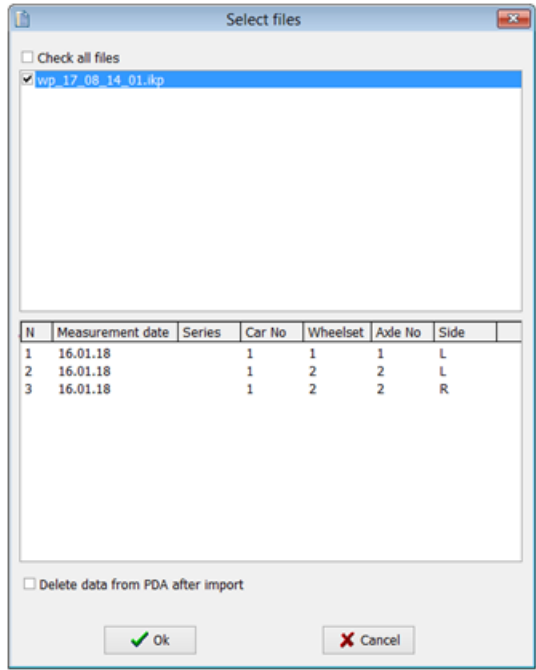
23.1.1. Transfer of database file to PC


To transfer the database file from PDA to PC, it is necessary to:

- select **PDA > Import Data**



- mark the required files in the emerged window and click **OK**

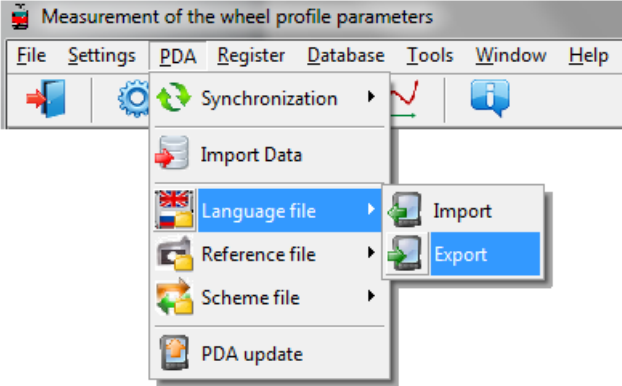


 Double-click on the selected file in order to see information about saved data.

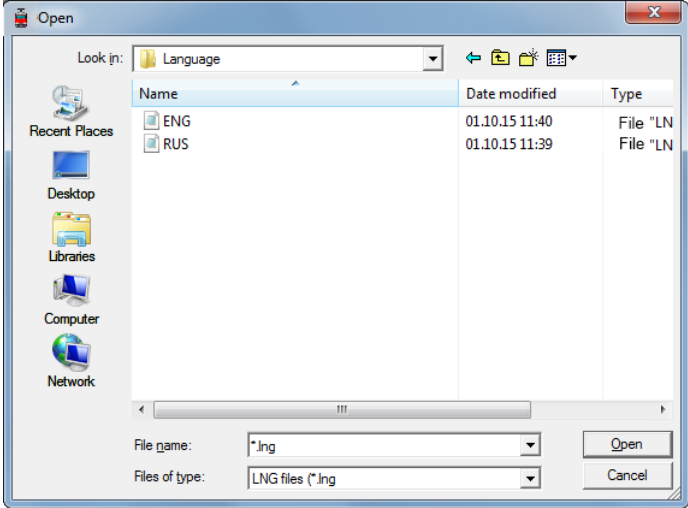
23.1.2. Transfer of language file from PC to PDA

To transfer the language file from PC to PDA, it is necessary to:

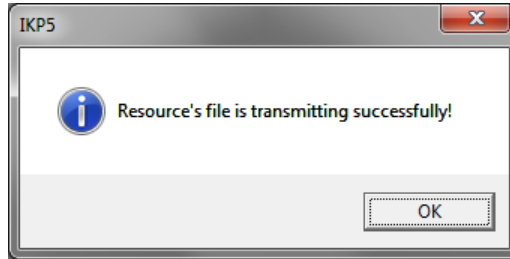
- select **PDA > Language file > Export**



- select the required file



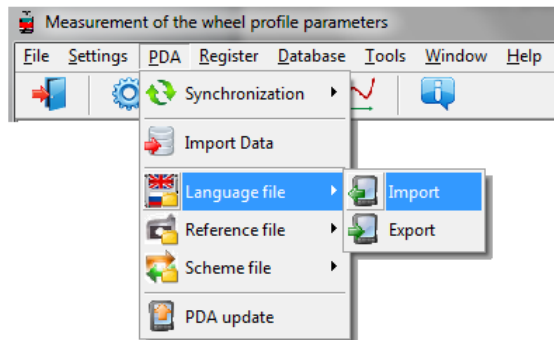
If transfer is successful, the screen will show:



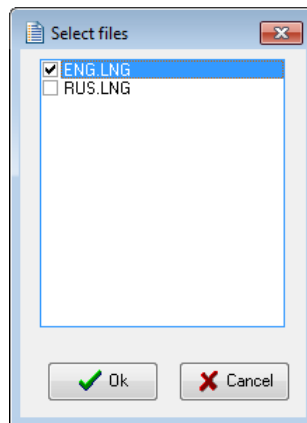
23.1.3. Transfer of language file from PDA to PC

To transfer the language file from PDA to PC, it is necessary to:

- select **PDA > Language file > Import**



- select the required file

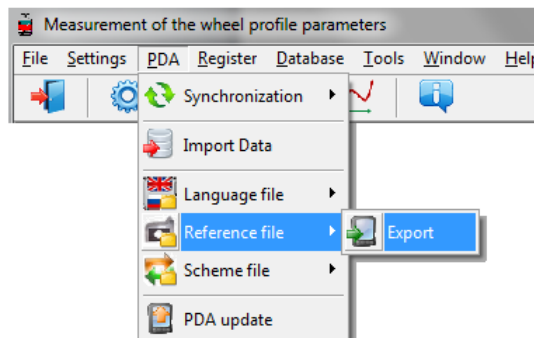


If transfer is successful, the selected files will be saved to the specified path.

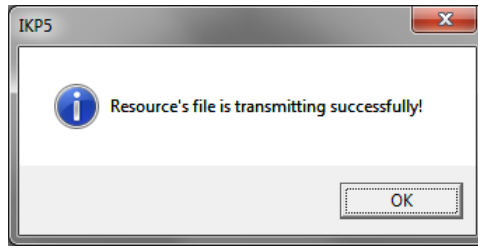
23.1.4. Transfer of reference profile files from PC to PDA

To transfer the reference profile file from PC to PDA, it is necessary to:

- select **PDA > Reference file > Export**



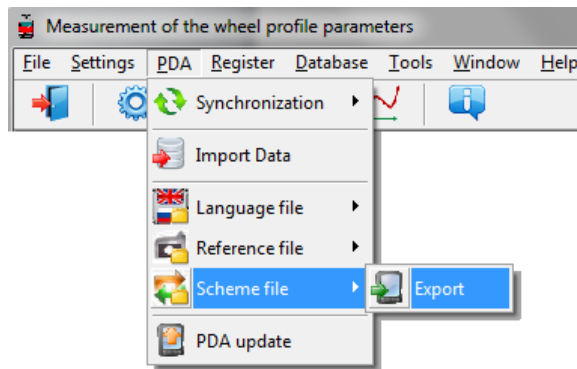
- select the required **.ref** file
- If transfer is successful, the screen will show:



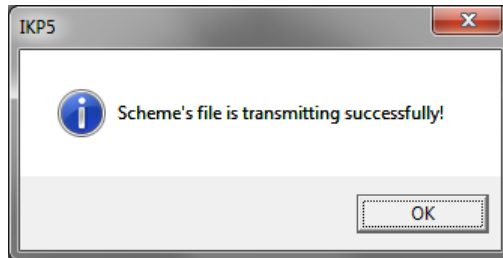
23.1.5. Transfer of processing scheme file from PC to PDA

To transfer the processing scheme file from PC to PDA, it is necessary to:

- select **PDA > Scheme file > Export**



- select the required **.sch** file
- If transfer is successful, the screen will show:



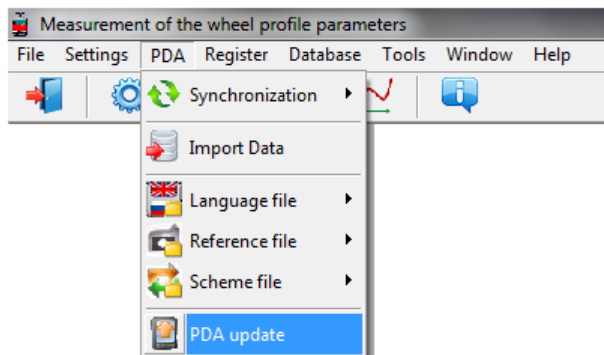
23.1.6. Updating of PDA software

The latest software version can be downloaded from the website:

www.riftek.com/media/documents/ikp/lkp5_PDA_Software.zip.

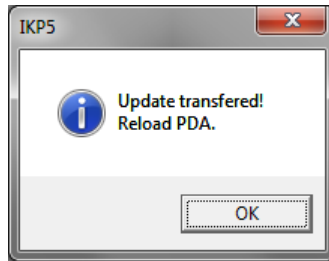
To transfer the update file to PDA, it is necessary to:

- select **PDA > PDA update**



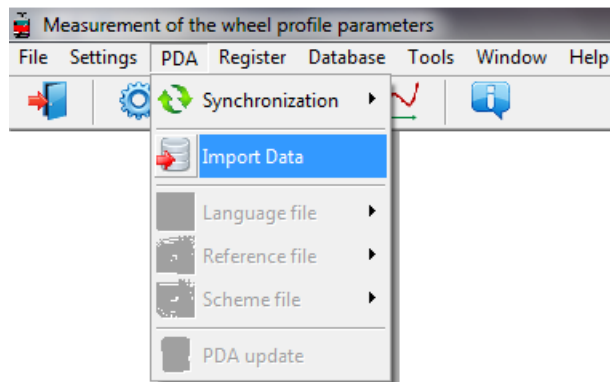
- select file for transfer

If transfer is successful, the window will appear:



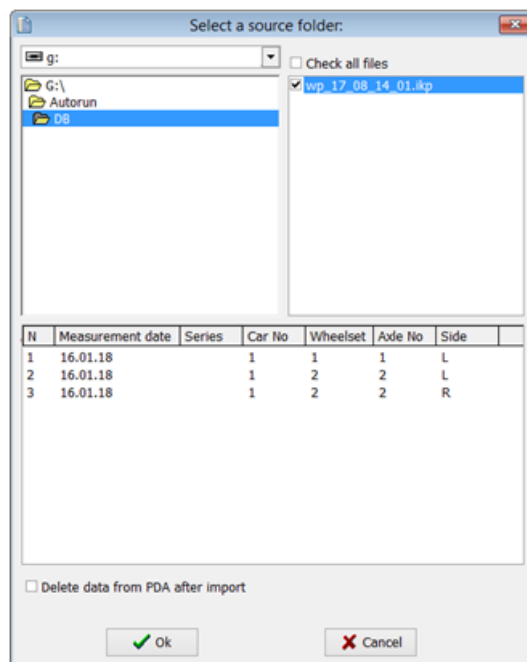
23.2. Mass Storage synchronization

When you select this type of synchronization, PDA is detected as an external storage device. Therefore, the only **Import Data** item is active. Transfer of language/scheme/reference files from PDA to PC and back can be performed by simple copying.



To transfer database files from PDA to PC, it is necessary to:

- select **PDA > Import Data**
- specify the path to the database on PDA (by default, **SDMMC\Autorun\DB**)




- mark the required files in the emerged window and click **OK**

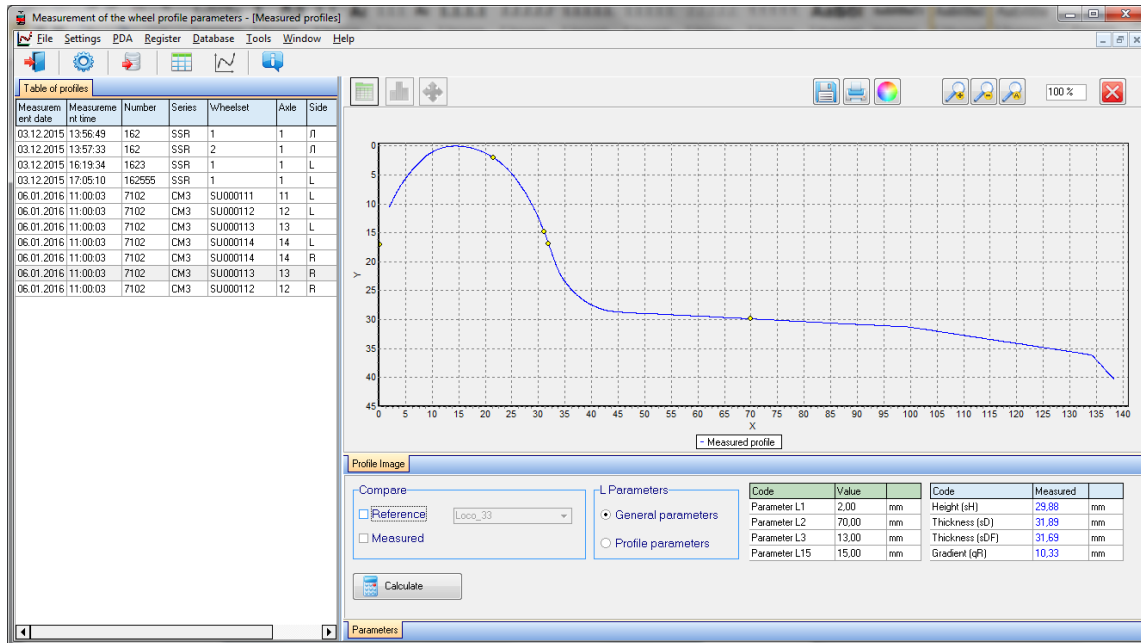


Double-click on the selected file in order to see information about saved data.

24. Working with profilograms and wear calculations

24.1. Browsing the graph and profile coordinates







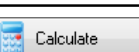

To browse the saved profiles of the rolling surface, select **Database > Profiles**, or click the **Profiles** button - .



At the left side of the window you can see the **Table of profiles** tab, which contains a list of saved profiles. The table displays only those identification parameters of the wheel, which were selected in the parameters window (see par. 22.1.).

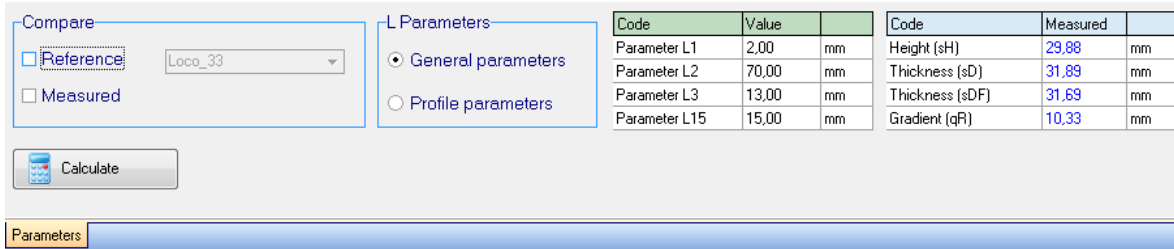
When selecting a profile, it is possible to browse a graphical image and geometric parameters of the measured wheel. To browse the coordinates of the selected profile, you need to click the **Profile Values** button. After that, an additional tab with the measured coordinates will appear.

Buttons:

	Show/hide the Wear graph
	Show/hide the Profile Values tab
	Show/hide the Profile alignment tab
	Save the profile image to file (.bmp file)
	Print the profile image
	Change the background color of the graph
	Zoom in/out the profile graph
	Calculate geometric parameters of the wheel

24.2. "Parameters" tab

Calculated geometric parameters of the profile as well as L-parameters values are displayed on the **Parameters** tab, which is at the bottom of the window.



If needed it is possible to change settings of the calculated parameters or support points (see par. [22.1](#)).

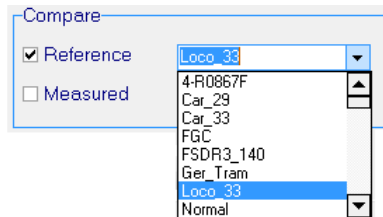
24.2.1. Selecting a profile to compare

There are two ways to compare:

- with the reference profile,
- with the measured profile.

To compare the measured profile with the reference one, it is necessary to tick the **Reference** box.

When comparing with the reference profile, select the required reference profile in the drop-down list.



To compare two measured profiles (for example, profiles of left and right wheels), it is necessary to tick the **Measured** box. The **Table of profiles** tab will show an additional table for selecting a profile to compare.

24.2.2. Selecting L-parameters values

When calculating the geometric parameters of wheelsets, the specified support points are used (see par. [22.1.3](#)). There are two variants of L-parameters:

- General parameters
- Profile parameters

When selecting **General parameters**, values of L-parameters will be taken from the default parameters file (see par. [22.1.3](#)).

When selecting **Profile parameters**, values of L-parameters will be taken from the profile file, i.e. the values, which were set in PDA when measuring the wheelset (see par. [14.3](#)).

Values of L-parameters are displayed on the screen in the table of parameters.

Code	Value	
Parameter L1	2,00	mm
Parameter L2	70,00	mm
Parameter L3	13,00	mm
Parameter L15	15,00	mm

If necessary, it is possible to edit any value and to recalculate values of geometric parameters of the flange. To do it, click **Calculate**. Parameters of the measured profile and selected reference will be recalculated.

24.2.3. Geometric parameters of the profile

The table of calculated geometric parameters displays only those parameters, which were selected in the parameters window (see par. [22.1.2](#)).

Code	Measured	Reference	
Height (sH)	29,87	28,00	mm
Thickness (sD)	31,89	32,32	mm
Gradient (qR)	10,33	9,10	mm

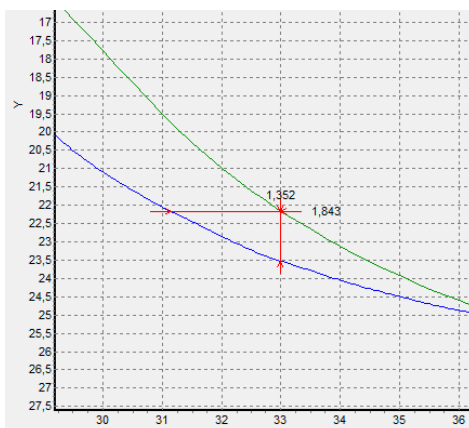
Parameters, which are beyond the set tolerances, are highlighted in red/orange (see par. [22.3.5](#)).

58

24.3. Wear calculation

24.3.1. Fast wear calculation

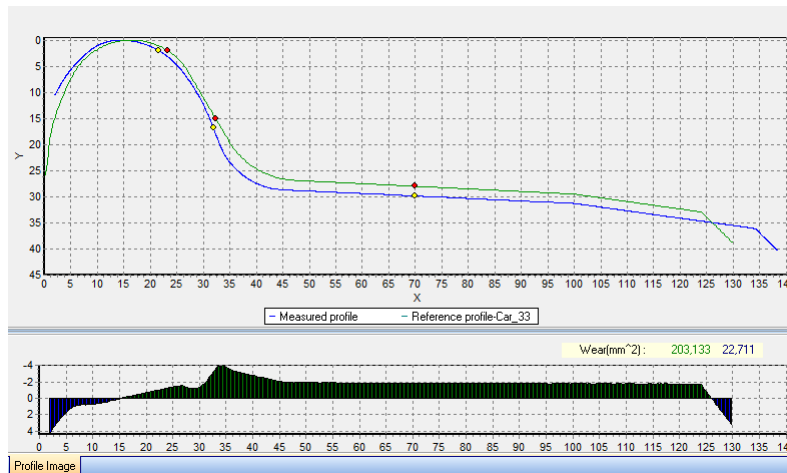
To obtain fast calculation of the profile wear at a certain point relative to the reference, put cursor bar to any of the profiles, and when a cross-like (+) mouse cursor appears press the left mouse key. The resulting screen will show the value of the coordinate difference between profiles taken along X- and Y-axes, as shown by arrows:



To remove size indication from the screen, it is necessary to put cursor to any of the profiles and press the right mouse key.

24.3.2. Wear calculation at all points

To calculate the wear at all points of the measured profile, it is necessary to click the **Wear** button. Calculated wear will be displayed on the screen in a graphic form:



The graph displays positive and negative values of the wear area. Value of the wear area is calculated in square millimeters with respect to the selected reference profile:

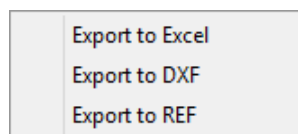
Wear(mm²): 203,133 22,711

To view the table of wear values, it is necessary to select **Profile Values > Wear**. The table will show deviations of the selected profile from the reference profile in two directions (X and Y).

N	Values on axis X	Values on axis Y	N	Values on axis X	Measured on axis Y	Reference on axis Y	Wear on axis Y
1	1,56	11,35	1	1,61	11,31	11,57	0,26
2	1,61	11,31	2	1,86	10,90	10,96	0,06
3	1,66	11,26	3	2,11	10,31	10,40	0,09
4	1,71	11,21	4	2,36	9,74	9,87	0,13
5	1,76	11,11	5	2,61	9,22	9,36	0,13
6	1,81	11,02	6	2,86	8,81	8,90	0,10
7	1,86	10,91	7	3,11	8,40	8,45	0,06
8	1,91	10,79	8	3,36	7,95	8,01	0,06
9	1,96	10,67	9	3,61	7,50	7,59	0,10
10	2,01	10,56	10	3,86	7,10	7,22	0,13
11	2,06	10,44	11	4,11	6,72	6,85	0,13
12	2,11	10,32	12	4,36	6,37	6,50	0,13
13	2,16	10,21	13	4,61	6,06	6,16	0,09
14	2,21	10,09	14	4,86	5,75	5,82	0,07
15	2,26	9,98	15	5,11	5,41	5,50	0,09
16	2,31	9,86	16	5,36	5,08	5,20	0,12
17	2,36	9,75	17	5,61	4,80	4,89	0,09
18	2,41	9,64	18	5,86	4,56	4,62	0,06
19	2,46	9,54	19	6,11	4,29	4,33	0,04
20	2,50	9,44	20	6,36	4,01	4,06	0,05
21	2,56	9,34	21	6,61	3,74	3,81	0,07
22	2,60	9,24	22	6,86	3,47	3,56	0,09
23	2,65	9,15	23	7,11	3,23	3,32	0,08
24	2,70	9,07	24	7,36	3,02	3,08	0,06
25	2,75	8,99	25	7,61	2,81	2,85	0,04
26	2,80	8,91	26	7,86	2,60	2,63	0,03

24.3.3. Export to Excel, DXF, REF

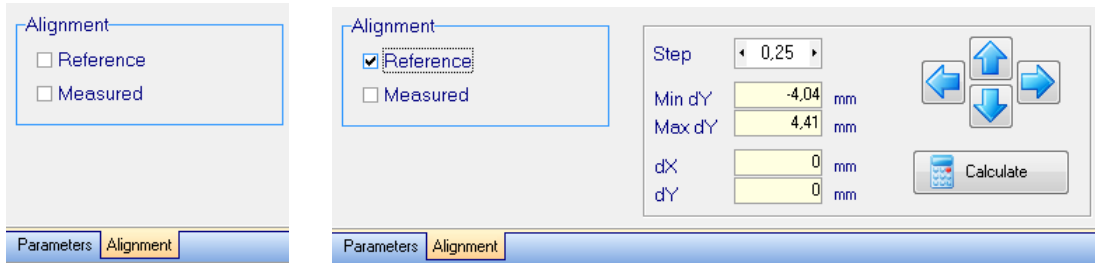
To export the table to the Excel or DXF format or to create the reference file (REF), it is necessary to right-click on the table. The pop-up menu will appear:



Select the needed menu item.

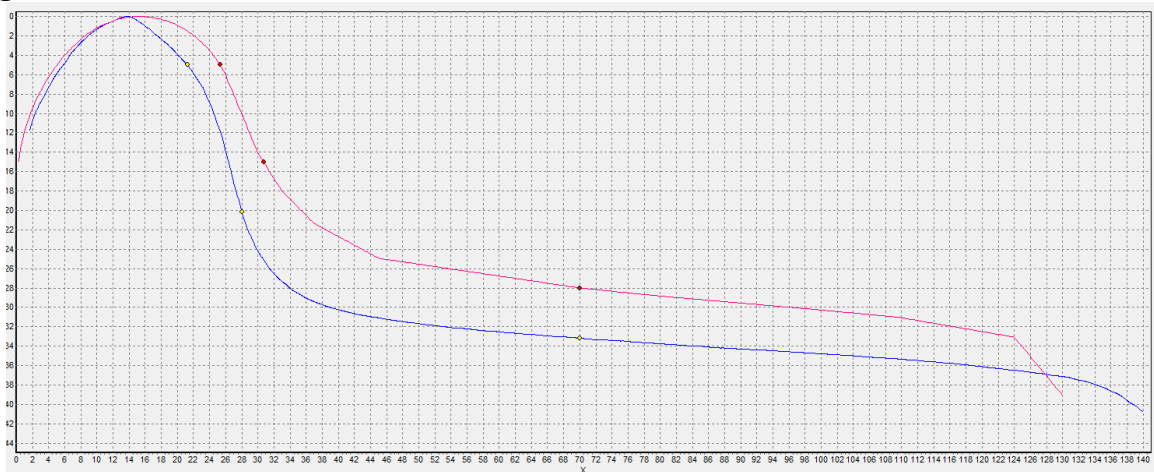
24.4. Alignment of profiles

For alignment (vertical translation) of profiles, you need to click the **Alignment** button. The program will display an additional tab, where you can select a profile: **Reference** or **Measured**. The selected profile will be marked with red.



After selecting the profile, the screen will display the maximum and minimum deviations of the selected profile from the reference profile [**Min dY..Max dY**].

Next, specify the translation step and move the profile by using the **Up/Down, Left/Right** buttons.



To save the changed profile, go to the tab of identification parameters of the profile and click **Save**.

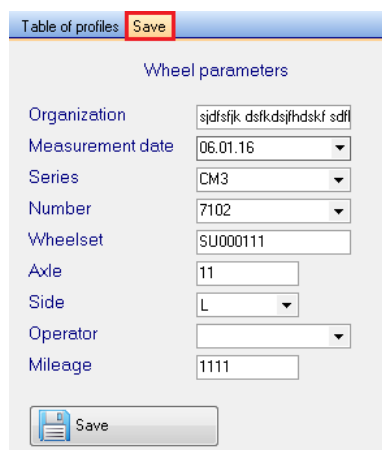


Table of profiles **Save**

Wheel parameters

Organization:

Measurement date:

Series:

Number:

Wheelset:

Axle:

Side:

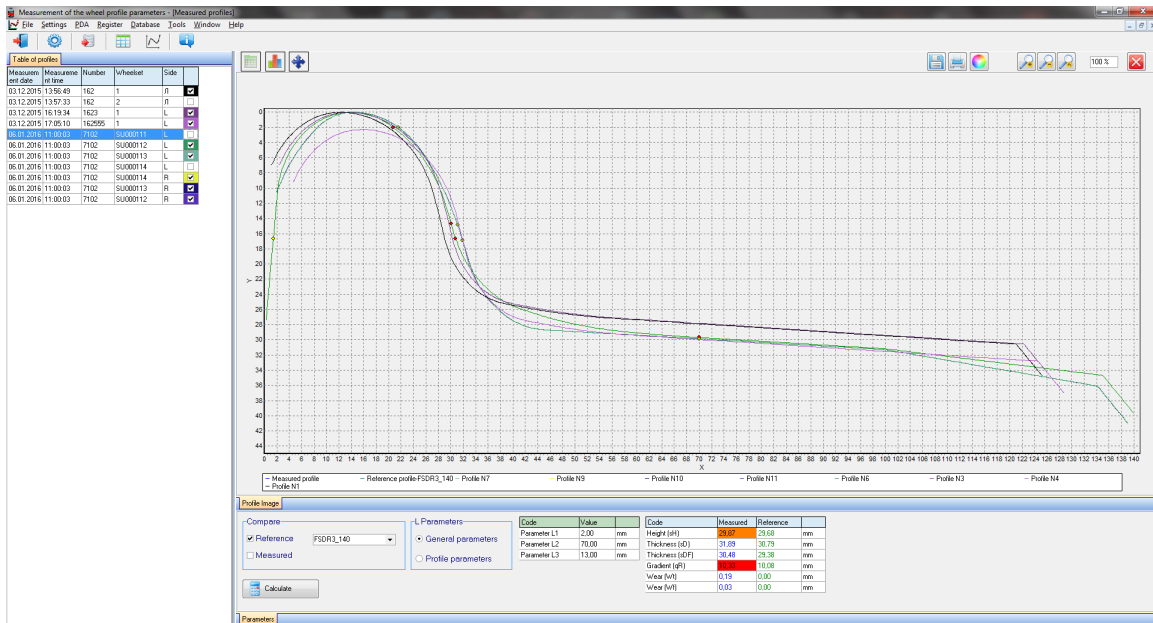
Operator:

Mileage:

To create a new profile, it is necessary to change the identification parameters of the profile.




24.5. Superposition of profiles

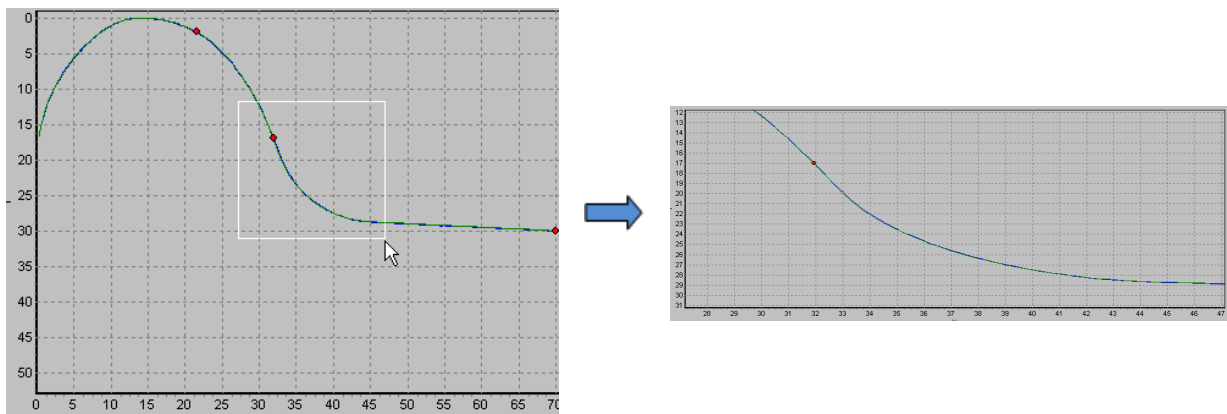
To superimpose several changed profiles, you need to tick the required profiles in the left table. Selected profiles will be displayed in different colors.



61

24.6. Rescaling

To change the image scale, mark a part of the image with the left mouse key, move the image by holding it with the right mouse key pressed, or with buttons **Increase** - , **Decrease** -  and **Show all** - .



25. Implementation of minimum wheel truing function

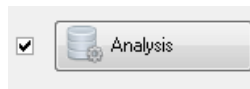
Select **Tools > Analysis of profiles**. The analysis of wheel profiles allows to choose such a type of the profile from the reference profiles, for which the total truing depth of two wheels would be minimal.

In the first table of profiles, select the first required profile of the wheelset (left wheel); in the second table of profiles, select the second required profile of the wheelset (right wheel).

The program allows to perform the automatic analysis by all the reference profiles, which stored in the database, or by the selected profile only.

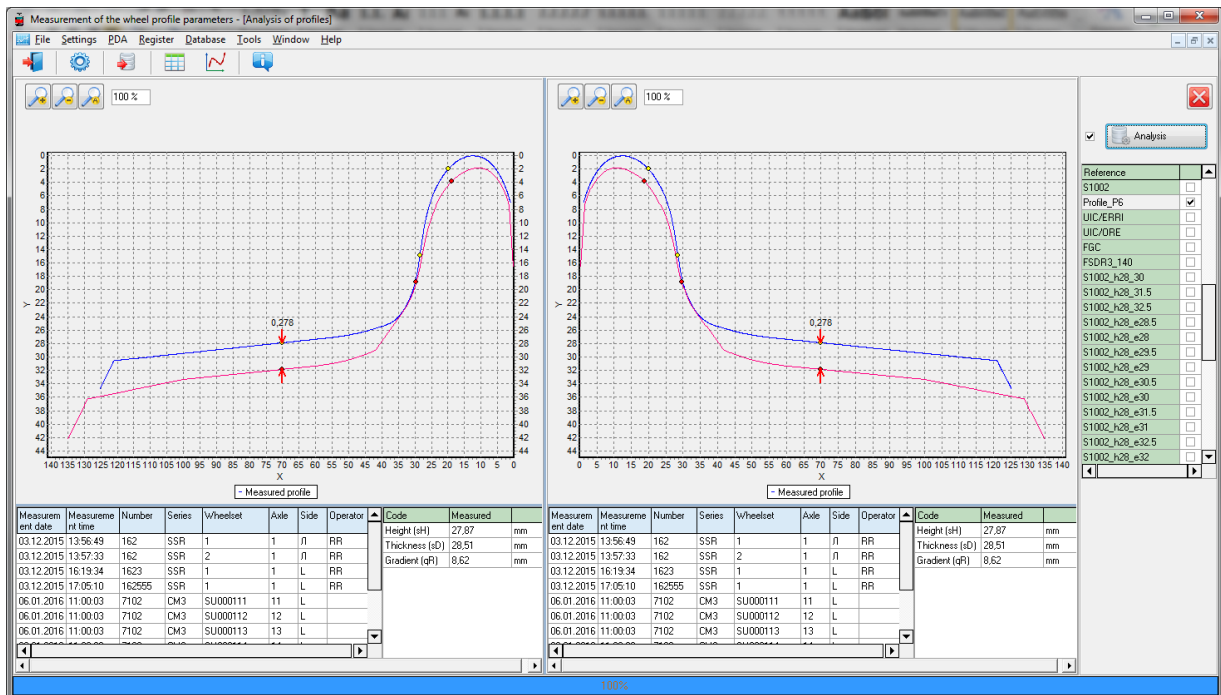
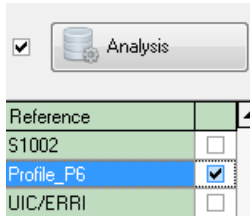
- Automatic analysis

Tick the box and click the **Analysis** button. Profiles in the table of references must not be marked.



- Analysis by the selected profile

Select the reference profile for analysis and click the **Analysis** button.

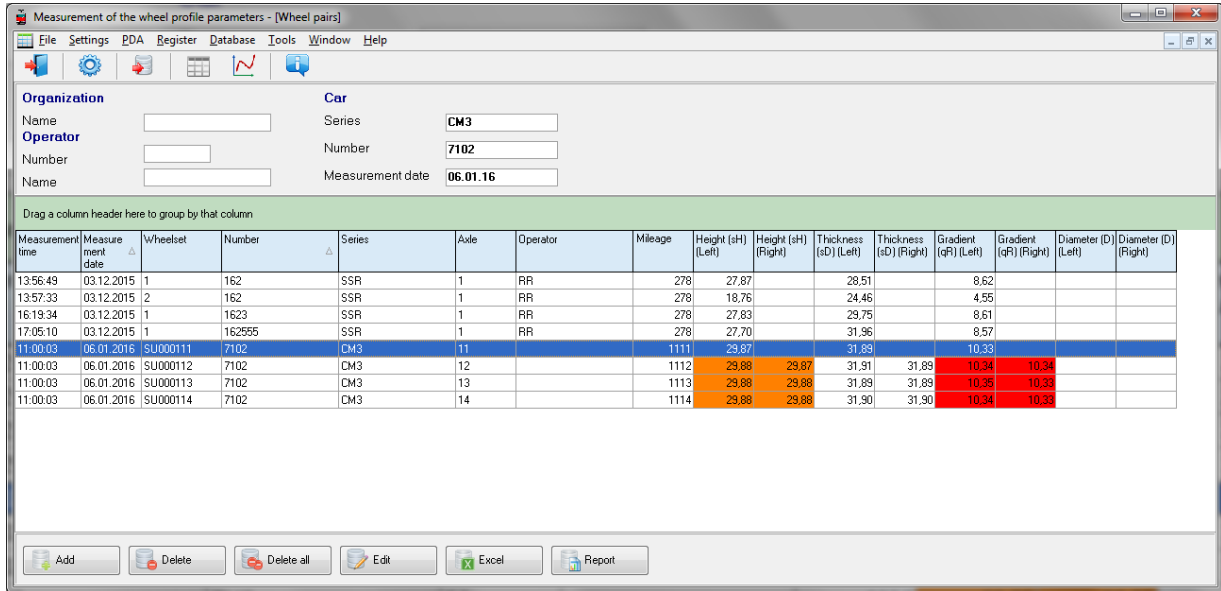


To know the wheel cutting depth in a certain point, put the cursor to any profile, and when a cross-like (+) mouse cursor appears press the left mouse key. The resulting screen will show the value of difference between profiles along X- and Y-axes, as shown by arrows. To remove size indication from the screen, put cursor to any of the profiles and press the right mouse key.

26. Scanning and editing of data

26.1. Scanning and filtering of data

Select **Database > Table** in the menu or click the **Table** button - . The form with results will be as follows:



- **Hide/show the field**

The table displays the identification and geometric parameters of the wheelset, which are selected for displaying in the parameters settings (see par. [22.1.1](#) and [22.1.2](#)).

- **Sorting of data**

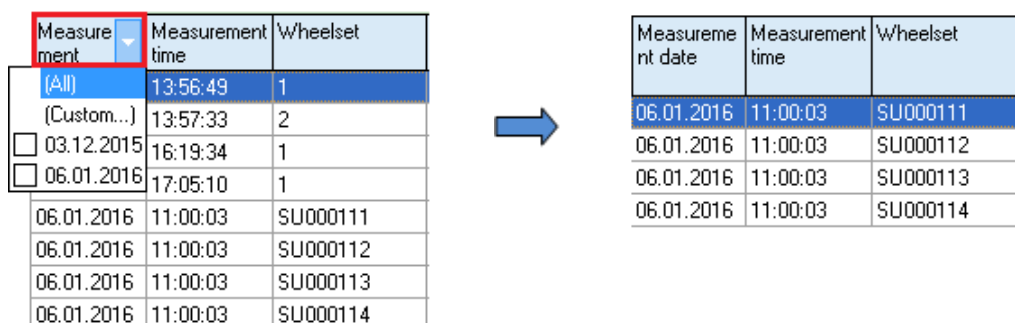
To sort data for any of the fields, click the left mouse key on the header of the field column:



To cancel data sorting, press the **Ctrl** key and click the left mouse key on the header of the field column.

- **Filtering of data**

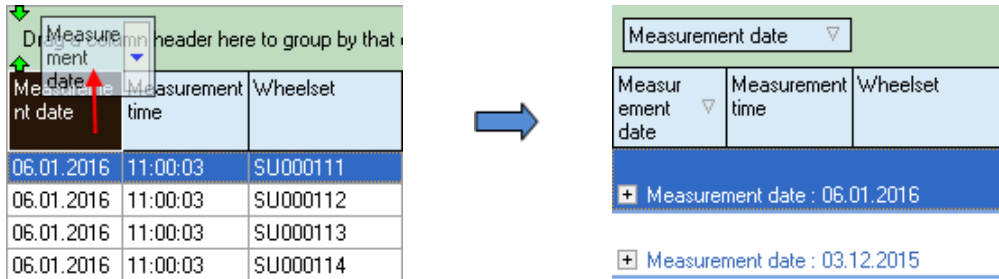
In order to filter data in any of the fields, click the left mouse key on the header of the field grouping, and select the required value in the emerged drop-down list:



To cancel filtering, all steps should be taken in the reverse order.

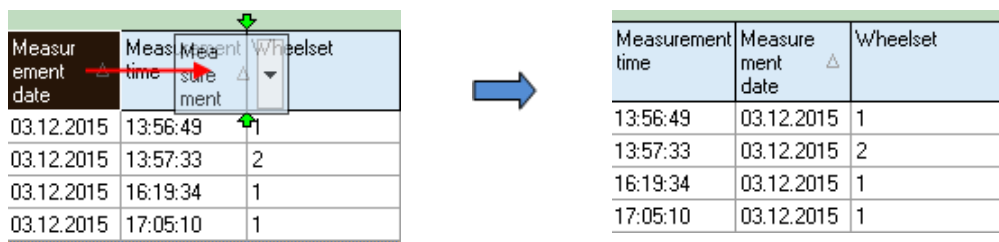
• **Data grouping**

To group data for any of the fields, click the left mouse key on the header of the field column, and, with the mouse key pressed, drag it onto the table header:









• **Changing of the field position order**

To change the field position, click the left mouse key on the header of the field column and, with the mouse key pressed, drag it to the required position:



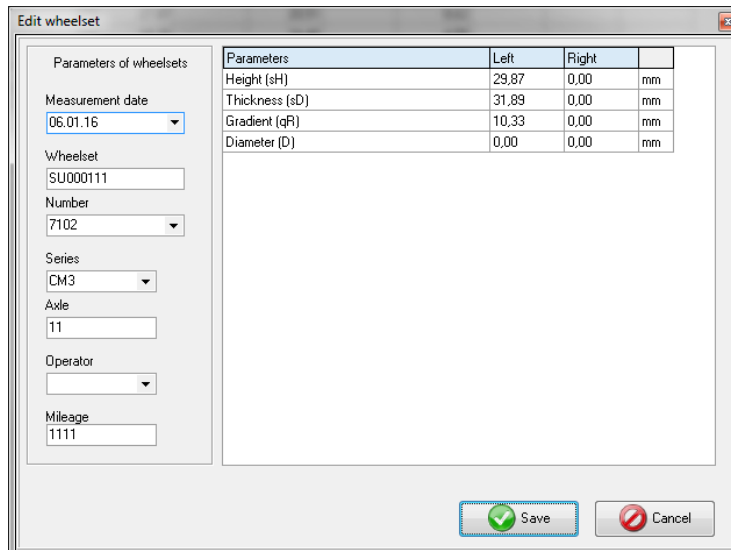
Buttons:

	Add the wheel pair
	Delete the selected wheel pair
	Delete all wheel pairs
	Edit the selected wheel pair
	Export the coordinates of wheel pairs to the Excel format
	Report preparation

26.2. Editing data

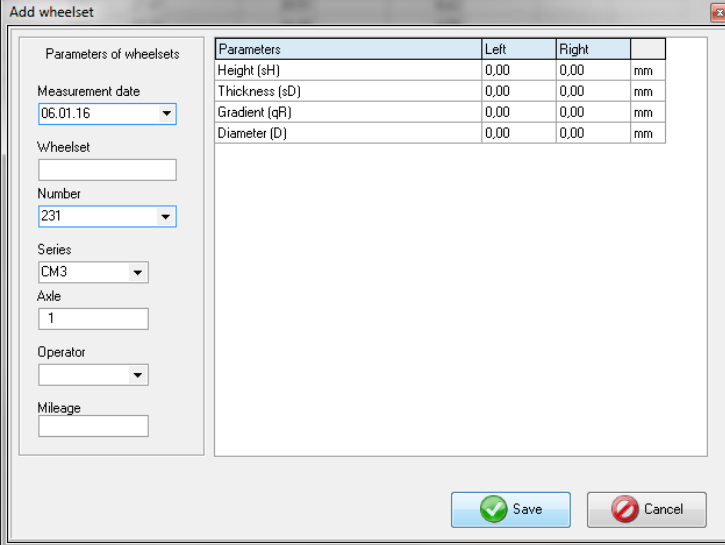
You can edit, add and remove data in/from the database.

• **Editing data**



To edit the current entry, click the **Edit** button and input/change required values of parameters. After the editing is complete, click the **Save** button.

- **Adding data**



Parameters	Left	Right	
Height (sH)	0,00	0,00	mm
Thickness (sD)	0,00	0,00	mm
Gradient (qR)	0,00	0,00	mm
Diameter (D)	0,00	0,00	mm

Parameters of wheelsets

Measurement date: 06.01.16

Wheelset:

Number: 231

Series: CM3

Axle: 1

Operator:

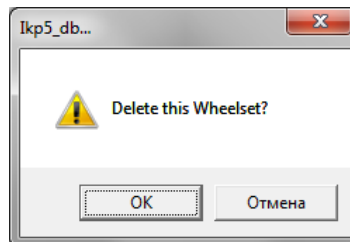
Mileage:

Buttons: Save, Cancel

To add a new data entry, click the **Add** button and type required parameter values. After the editing is complete, click the **Save** button.

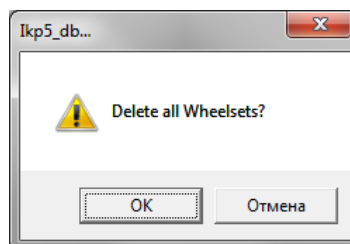
- **Deleting data**

To delete the current entry, click the **Delete** button and confirm the deletion.



- **Deleting all selected data**

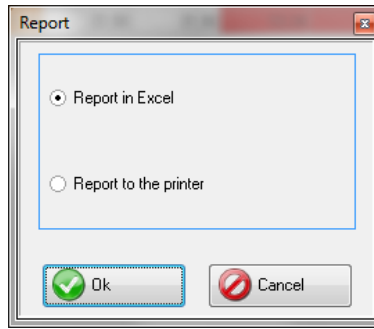
If it is necessary to delete not only one entry but several entries combined by some condition, filter the data according to the corresponding attribute (see par. [26.1.](#)), click the **Delete all** button and confirm the deletion.



26.3. Report preparation

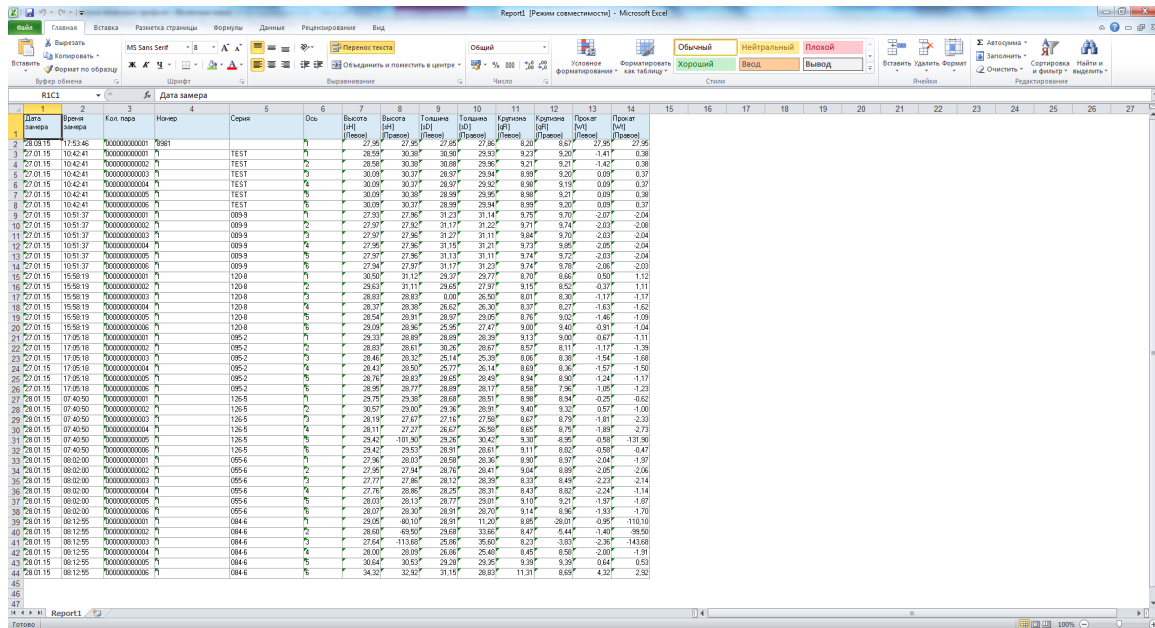
When staying in the mode of scanning and editing data, the user can prepare reports in **Excel**, **RTF**, **PDF** formats, or print out reports. When preparing the report, the sorting used at the moment is taken into account.

To generate a report, press the **Report** button. The program will offer to select the following options:



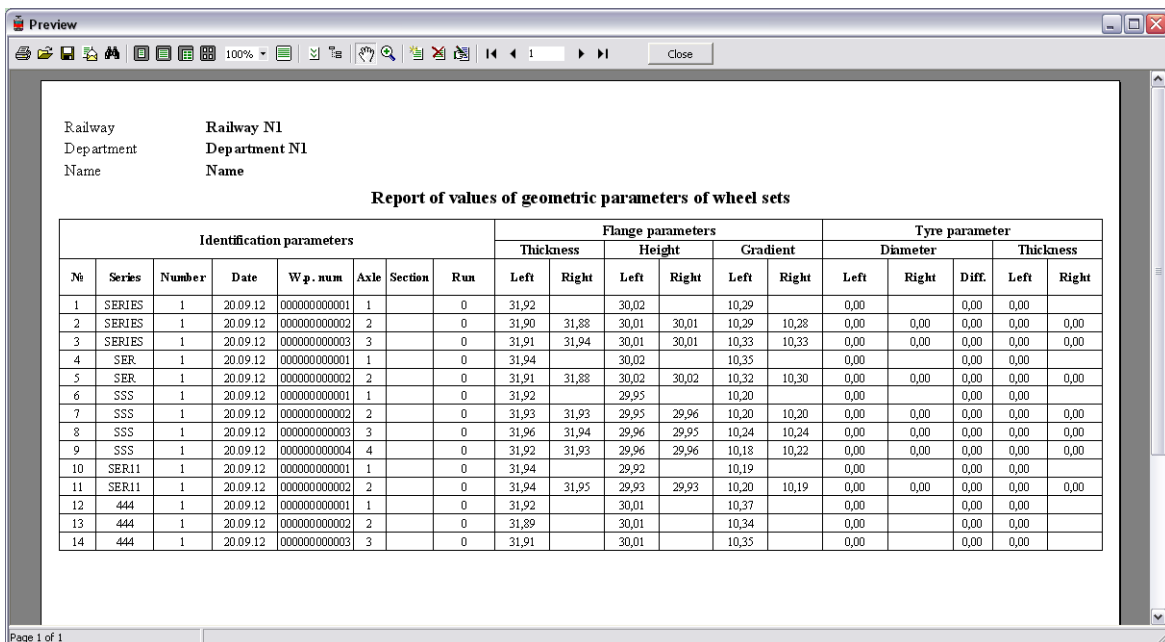
26.3.1. Excel-format report

To prepare a report in Excel format, select **Report in Excel** and click **OK**.




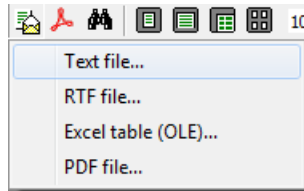
26.3.2. Report for printout

To prepare the report for printout, select **Report for printout** and click **OK**. Data will be presented in the form of report ready for printout.



The top toolbar contains the following buttons for operating with reports:

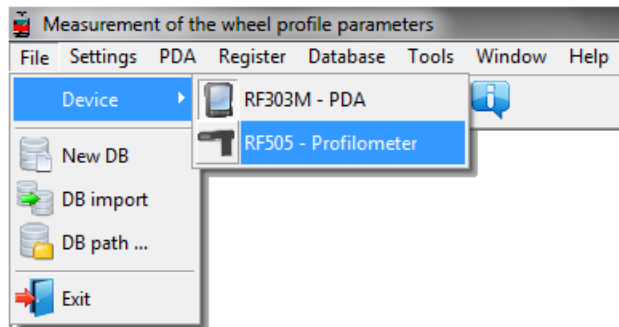
- To printout the report, click .
- To save in PDF format, click .
- To save in Excel, RTF or PDF, click  and select the format you need:



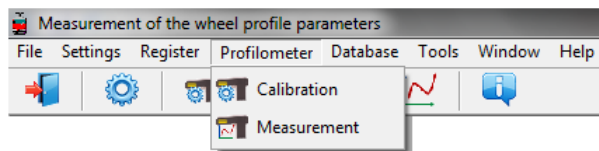
67

27. Taking measurements under PC control (without PDA)

The laser scanning module (RF505) can work under direct control of PC without PDA. To work under direct control of PC, it is necessary to select **File > Device > RF505-Profilometer** in the main menu.



In the main menu of the program, the **PDA** tab will be replaced with the **Profilometer** tab.



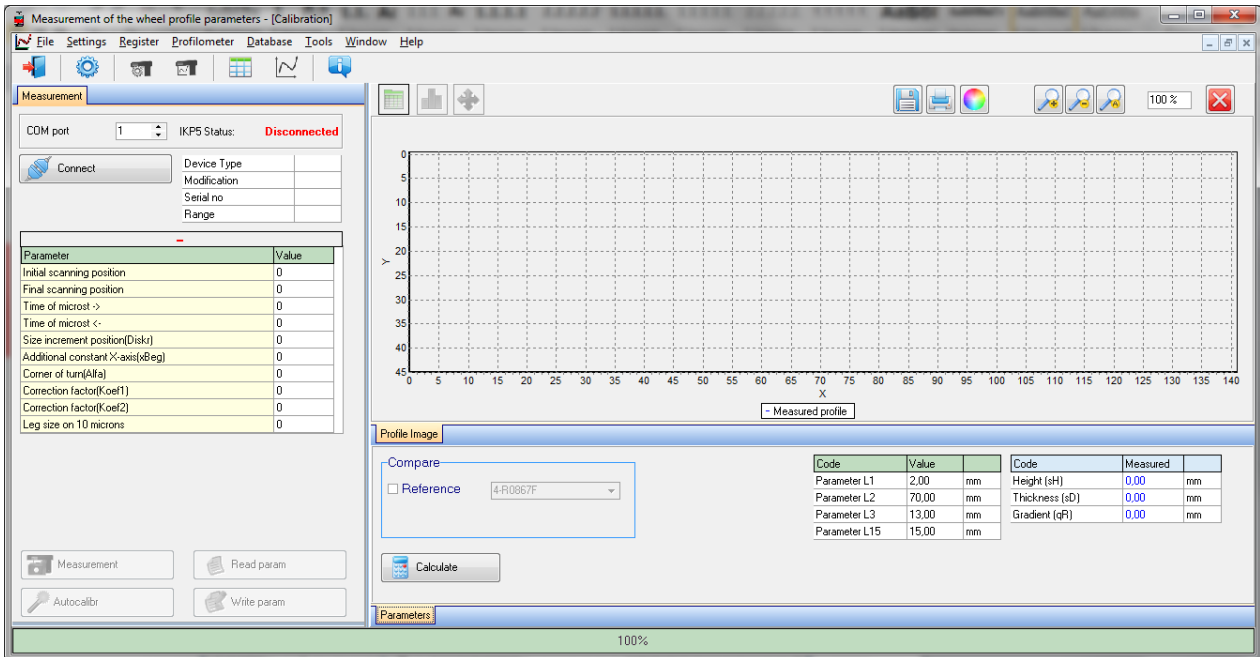
The menu contains two available items:

- Calibration
- Measurement

Before you start working with the profilometer, it is necessary to set the COM-port for Bluetooth-connection between the laser scanning module and PDA. The procedure is described in the User's manual that comes with the Bluetooth-adapter.

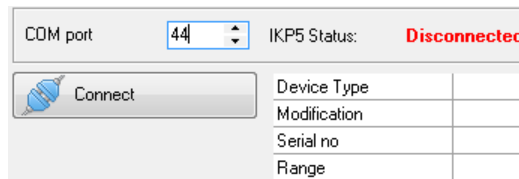
27.1. Calibration


To calibrate the device, select **Profilometer > Calibration**, or click .



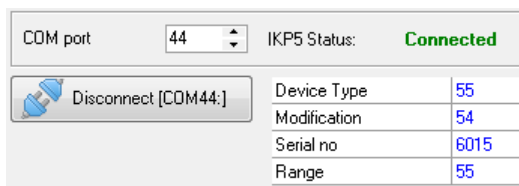
27.1.1. Bluetooth-connection

Select the COM-port and click the **Connect** button.



 For more information, refer to [p. 30](#).





If the connection is successful, the device will be identified, and calibration parameters will be obtained. The status will be changed to **Connected**.




The table of calibration parameters:

Parameter	Value
Initial scanning position	30
Final scanning position	2860
Time of microst ->	6
Time of microst <-	5
Size increment position(Diskr)	4935
Additional constant X-axis(xBeg)	5330
Corner of turn(Alfa)	63
Correction factor(Koef1)	0
Correction factor(Koef2)	0
Leg size on 10 microns	0

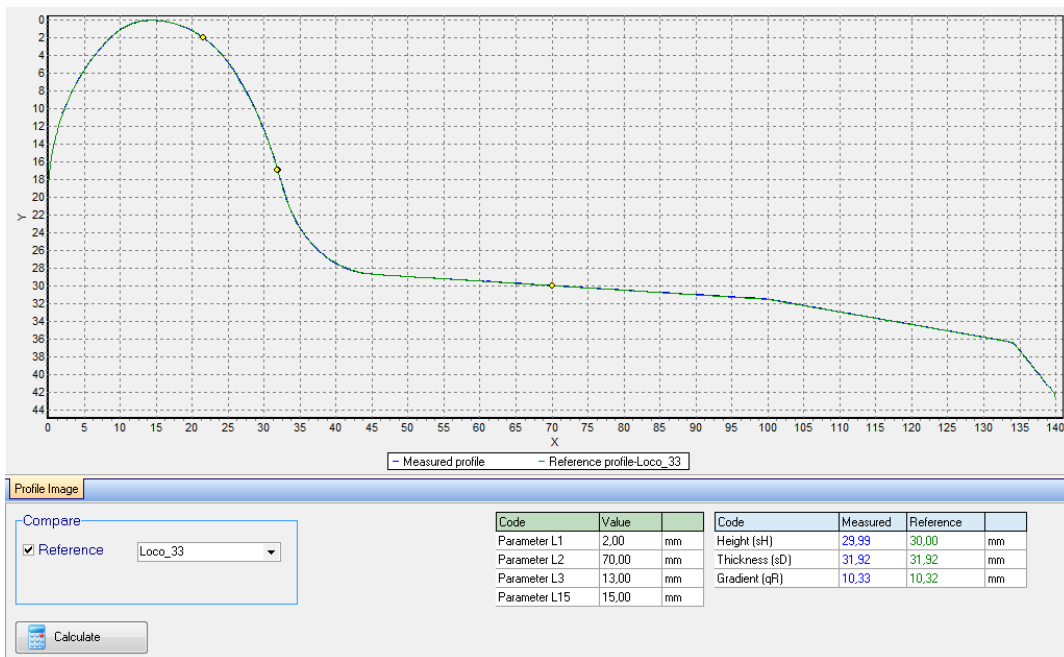
Buttons:

 Measurement	Measurement
 Read param	Reading calibration parameters
 Write param	Writing calibration parameters
 Autocalibr	Automatic setting of calibration parameters


 The **Auto calibration** button will be active, if at least one measurement of the profile is performed and the reference profile is selected.

27.1.2. Calibration of the profilometer

- Place the profilometer on the calibration block.
- Select the reference profile from the list (**Compare > Reference**).
- Perform the measurement (the **Measurement** button)
- Perform the calibration (the **Autocalibr** button).
- Save calibration parameters (the **Write param.** buton).



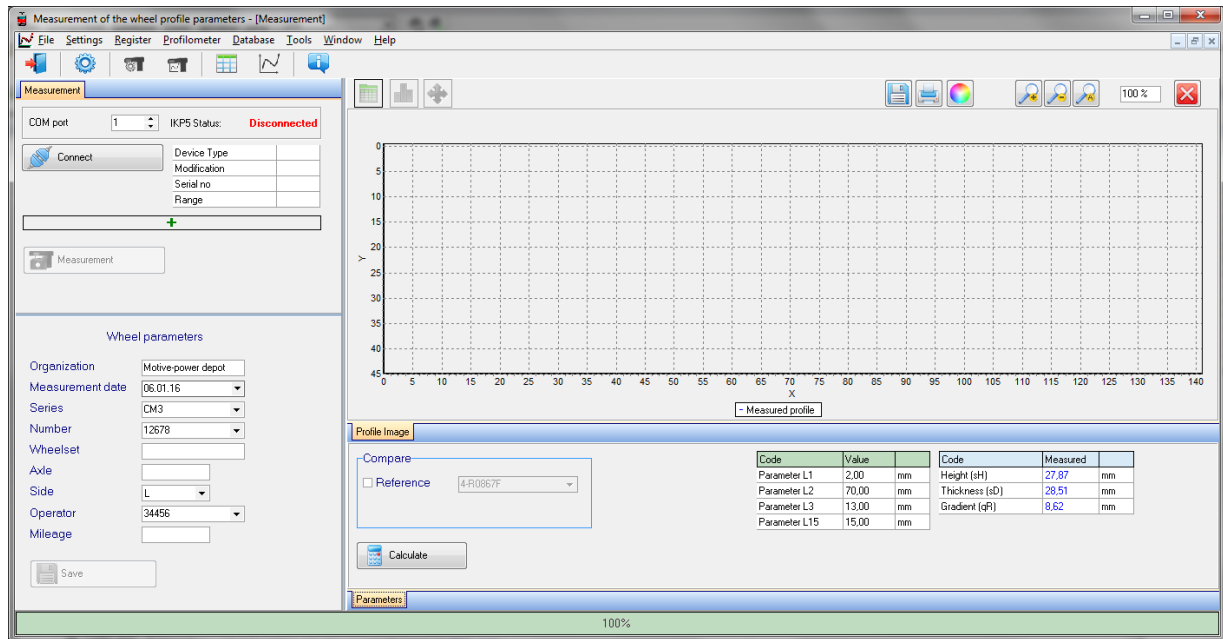
Calibration parameters can be set manually. To do it, click left mouse key on the field of the required parameter value, and enter the new one.

 **Attention!** Writing incorrect values of some parameters can lead to the incorrect work of the device.

Buttons functions, work with profiles and calculation of required parameters are described in par. [22](#).

27.2. Measurement by using PC

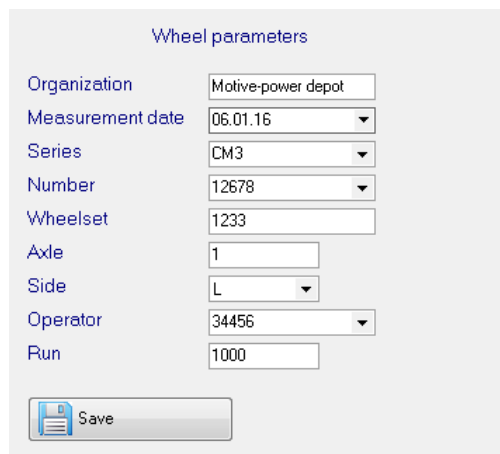
To measure, select **Profilometer > Measurement**, or click the button .



When the Bluetooth-connection is established (see par. [27.1.1](#)), the **Measurement** button is active.

27.2.1. Saving of data

- Place the profilometer on the wheel
- Perform the measurement (the **Measurement** button)
- Enter the identification parameters of the wheelset



- To save results, click **Save**
- The measured profile will be saved to the database

Buttons functions, work with profiles and calculation of required parameters are described in par. [22](#).

28. Annex 1. Charging procedure

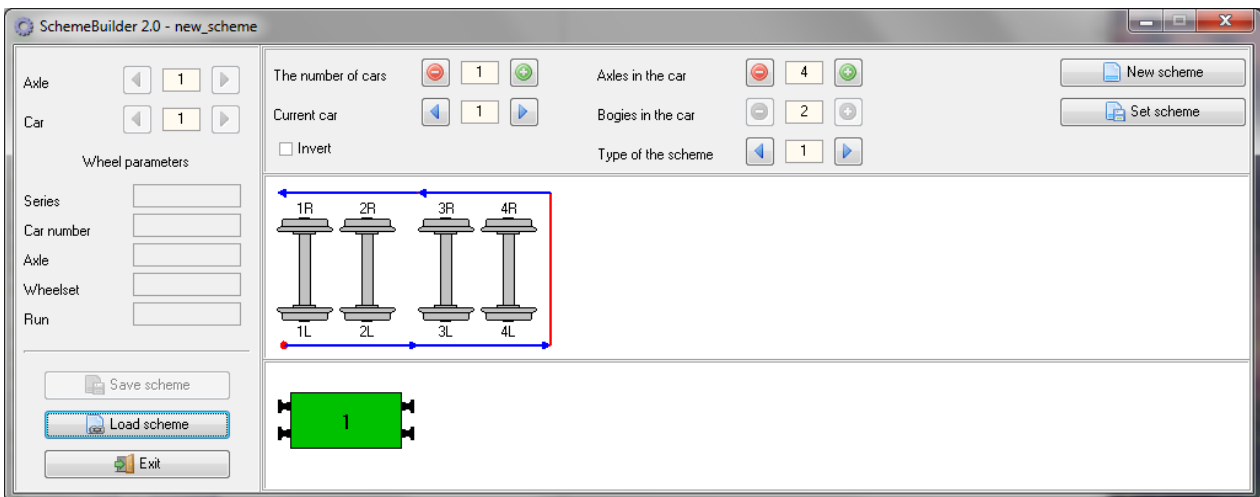
- Switch off the PDA (laser module)
- Connect the charging device to PDA (laser module)
- Connect the charging device to 220V AC
- Time of charging - 4 hours (full-charge indication: PDA - blue LED is lit; laser module - green LED is lit)
- Disconnect the charging device from 220V AC
- Disconnect the charging device from PDA (laser module)



Attention! Please follow the sequence of these points.

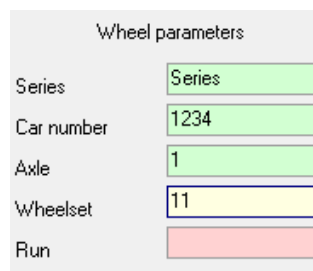
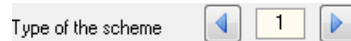
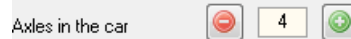
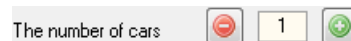
29. Annex 2. Program for creating the measurement schemes

To create the measurement schemes, use the special program **SchemeBuilder.exe**. When the program is started, the main window appears on the screen:



To form the scheme:

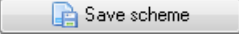
- Enter the number of cars
- Enter the number of axles in every car
- If the measurement of the car is performed in the reverse order, tick the box Invert
- Select the type of the scheme
- Click the button to accept
- Next, enter parameters of all wheelsets sequentially for each car

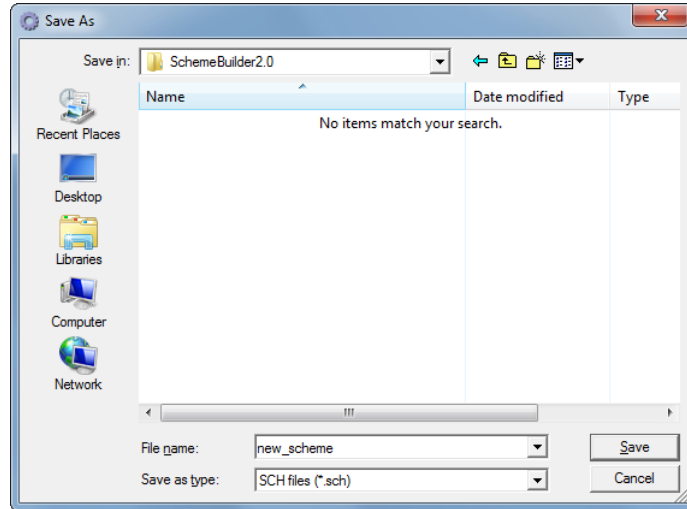


- The fields **Axle** and **Car** are used to navigate through the scheme

Axle

Car

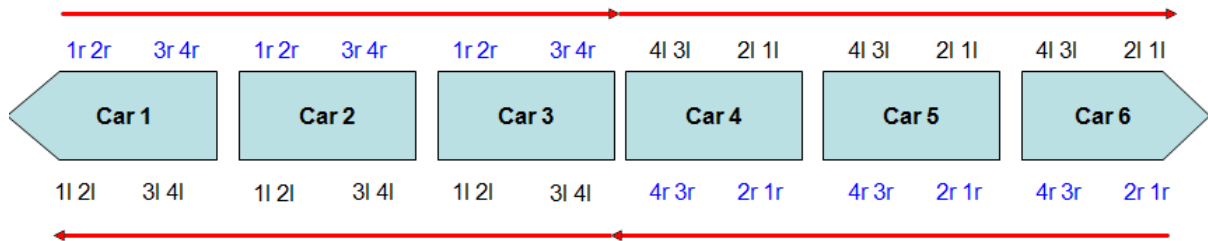
- Click the **Save scheme** button 
- Enter the name of the scheme in the dialog box window



The program allows to edit the existing scheme. To edit the scheme, click the **Load scheme** button and select the *.SCH file. After loading, you can edit and save the wheelset parameters.

To transfer the scheme file to PDA, use the procedure described in par. [23.1.5](#). **Clarification.** The measurement scheme is a text file with extension .sch. User can create and edit such file by using any text processor.

Example:



Scheme_EXAMPLE

```
{
1d-|SM 3|7102|1|11|SU11|11|1|1r|11|SU11|11|2|12|SU12|112|2r|12|SU12|112|3|13|SU13|113|3r|13|SU13|113|4|14|SU14|114|4r|14|SU14|114|;
2d-|SM 3|7202|1|12|SU21|21|1|1r|21|SU21|21|2|22|SU22|212|2r|22|SU22|212|3|23|SU23|213|3r|23|SU23|213|4|24|SU24|214|4r|24|SU24|214|;
3d-|SM 3|7302|1|13|SU31|31|1|1r|31|SU31|31|2|32|SU32|312|2r|32|SU32|312|3|33|SU33|313|3r|33|SU33|313|4|34|SU34|314|4r|34|SU34|314|;
4i-|SM 3|7402|4r|44|SU044|414|4|4r|44|SU44|414|3r|43|SU43|413|3|43|SU43|413|2r|42|SU42|412|2|42|SU42|412|1r|41|SU41|411|1|41|SU41|411|;
5i-|SM 3|7502|4r|54|SU54|514|4|5r|54|SU54|514|3r|53|SU53|513|3|53|SU53|513|2r|52|SU52|512|2|52|SU52|512|1r|51|SU51|511|1|51|SU51|511|;
6i-|SM 3|7602|4r|64|SU064|614|4|6r|64|SU64|614|3r|63|SU63|613|3|63|SU63|613|2r|62|SU62|612|2|62|SU62|612|1r|61|SU61|611|1|61|SU61|611|;
}
```

Where:

- 1d – coaches arranged in direct order (1 – sequence number)
- 1i – coached arranged in the reverse order (1 – sequence order)
- SM3 – coach series
- 7102 -number
- 1l – sequence number of wheel pair and the side (l- left/r-right)
- 11 – axle number
- SU11 – name of wheel set
- 111 – running distance of wheel set

30. Annex 3. Testing and calibration

We can supply the profilometer complete with an RF505.11 calibration-wheel simulation unit (Fig. 1A) and **RF505Calibr** calibration program that are designed for periodic testing and self-calibration of the profilometer.

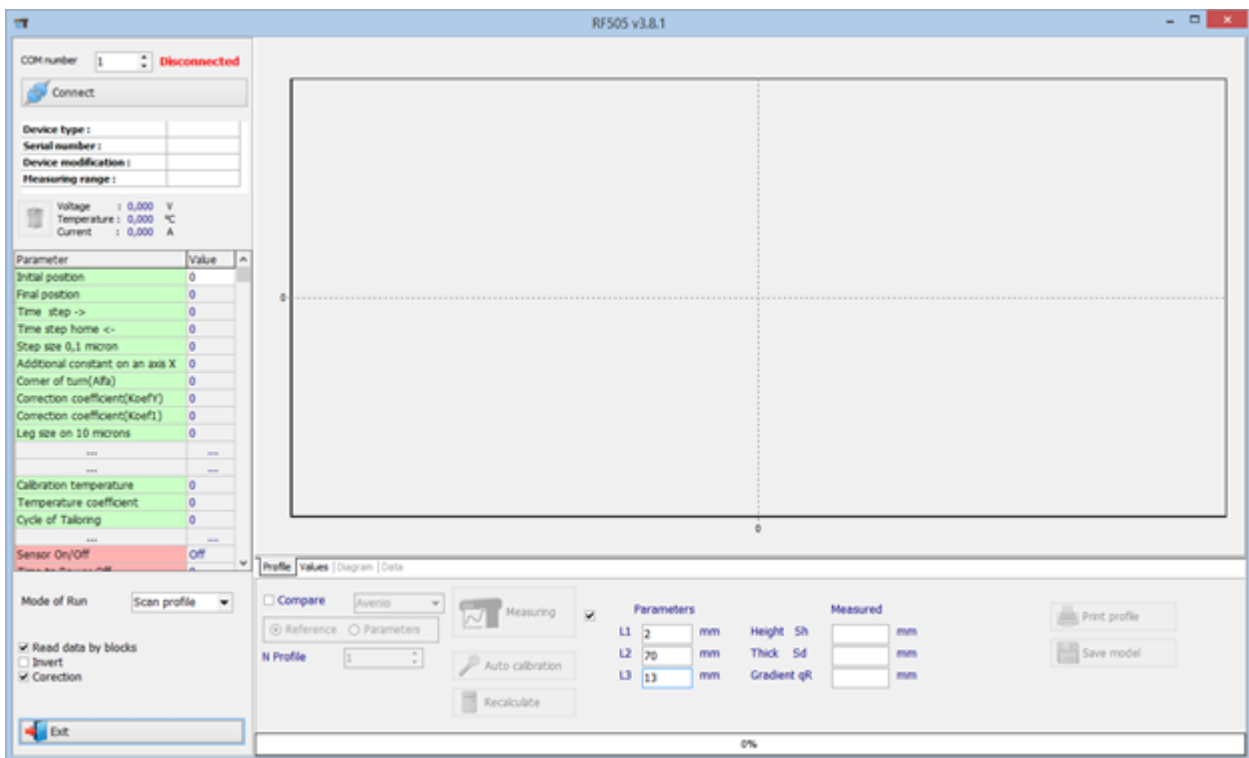
Instead of the calibration unit use can be made of the wheel with known profile entered to the database (see par. 22.3.6).

Before start the testing and calibration process, it is necessary to set the COM-port for Bluetooth-connection between the laser scanning module and PDA. The procedure is described in the user manual that comes with the Bluetooth-adapter.

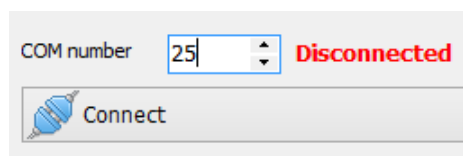
When you add the device, Windows will ask for the pairing code. The pairing code for each device consists of 4 symbols and is formed according to a serial number. For example, if a serial number is 04217, then a code will be 0427; if a serial number is 01318, then a code will be 0138, etc.

30.1. Preparation for testing/calibration

- Install the **RF505** program on the PC
- Install Bluetooth-connection between the scanning module and PC
- Place the profilometer on the calibration unit
- Run **RF505** program



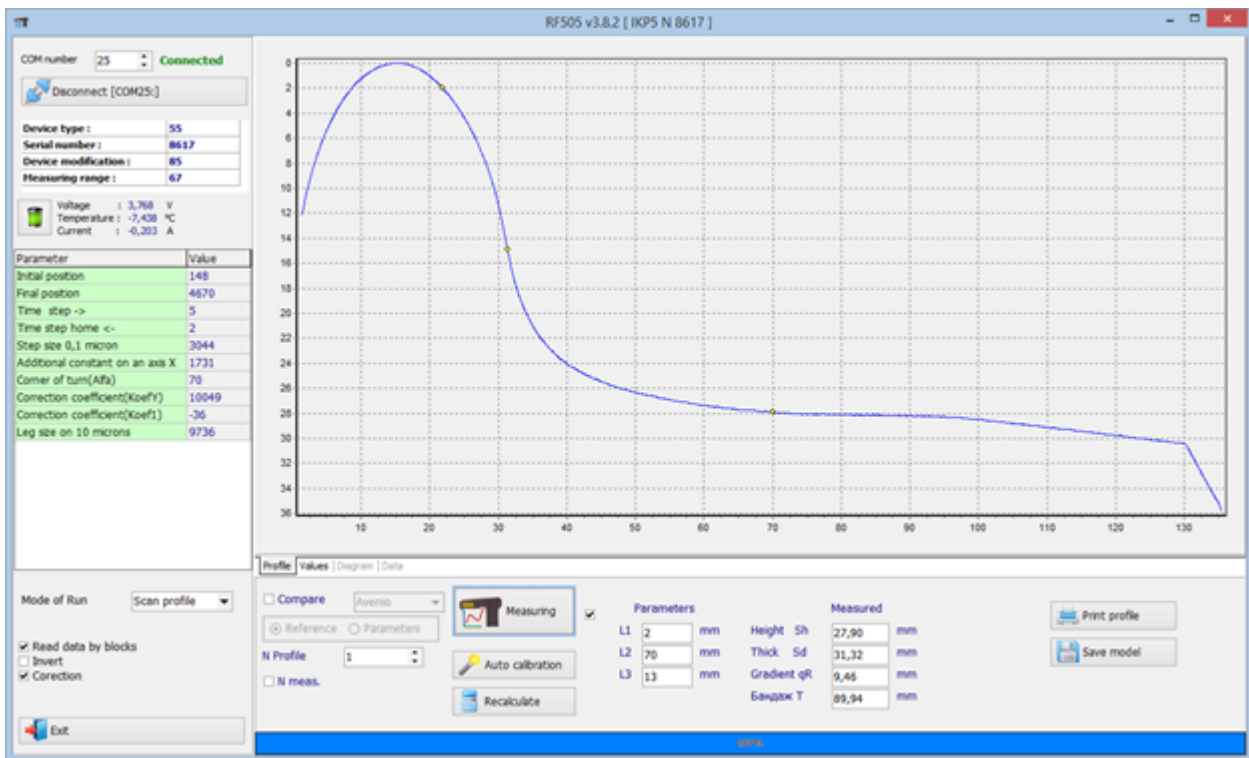
- To install Bluetooth-connection, select the required port.



The device will be identified, and calibration parameters will be read.

- To perform the measurement, pass to the **Profile** tab and click **Measurement**. After measuring, the display will show the measured profile and the calculated

geometric parameters of the profile: Height (Sh), Thickness (Sd), Slope (qR). Parameters are measured at support points L1, L2, L3.

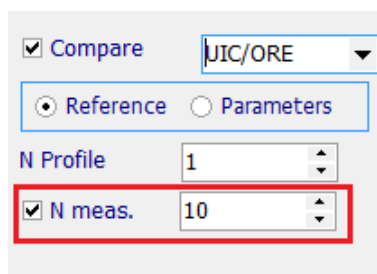


- To compare with the reference, tick the **Compare** box and select the required reference profile in the **Reference** drop-down list.

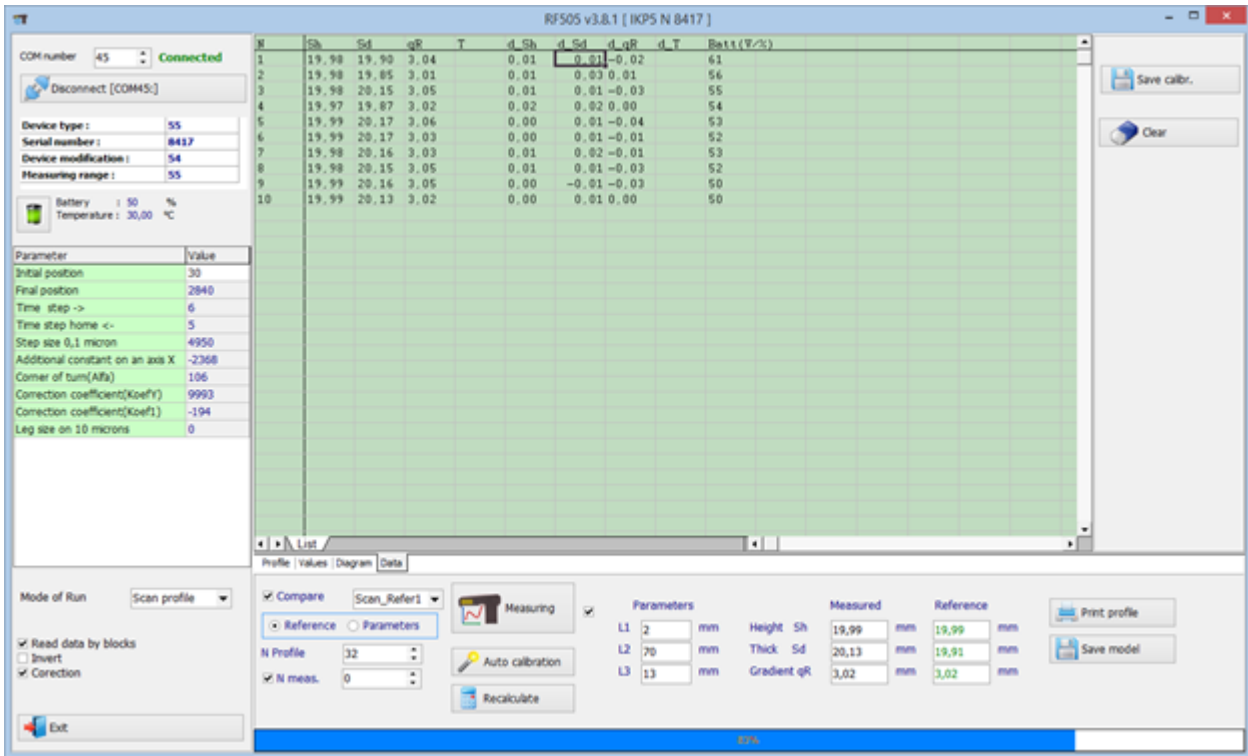
30.2. Testing

To carry out automatic testing, do the following steps:

- Tick the **N meas.** box (number of measurements)
- Specify the number of measurements (5-10)
- Click the **Measuring** button

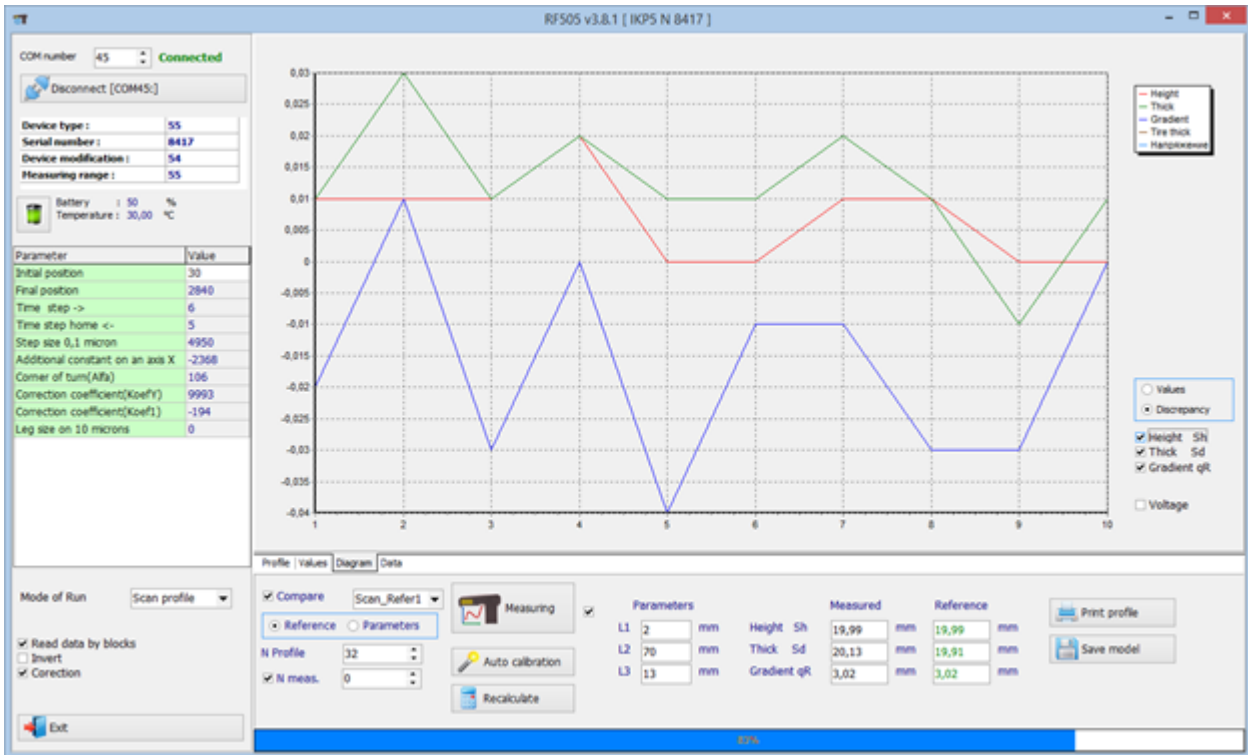


The scanning module will make the specified number of measurements whose results will be entered to the table (the **Data** tab). The first three columns will present measured values of height (Sh), thickness (Sd), and flange slope (qR), while the other three columns will present deviations of the measured values from the reference values (d_Sh, d_Sd, d_qR).



75

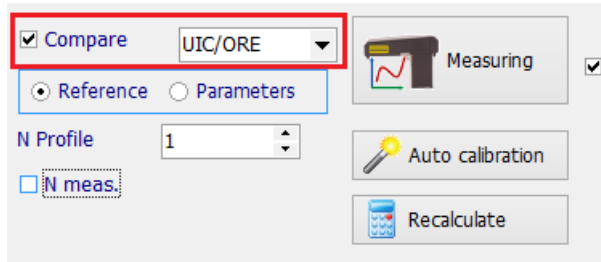
The **Diagram** tab is intended for displaying the diagram of values/deviations of the measured profile from the selected reference. Deviation of the flange height and thickness from the reference values must not be more than 0.1 mm. If deviations exceed the permissible value, it is necessary to perform calibration of the scanning module.



30.3. Calibration

To carry out automatic calibration, do the following steps:

- Select the reference profile from the list



- Perform the measurement (the **Measuring** button)
- Perform the calibration (the **Auto calibration** button)
- When scanning is complete, perform the testing procedure in accordance with [30.2](#). In case of positive result, save parameters:
 - Right-click on the table and select **Write**
 - Right-click on the table and select **Write to FLASH**

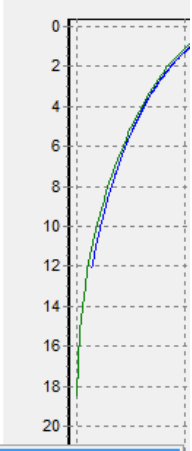
COM number 25 Connected

Disconnect [COM25:]

Device type :	55
Serial number :	8617
Device modification :	85
Measuring range :	67

Voltage : 3,768 V
Temperature : -7,438 °C
Current : -0,203 A

Parameter	Value
Initial position	148
Final position	4670
Time step ->	5
Time step home <-	2
Step size 0,1 micron	30
Additional constant on an axis X	1731
Corner of turn(Alfa)	70
Correction coefficient(KoefY)	10049
Correction coefficient(Koef1)	-36
Leg size on 10 microns	9736



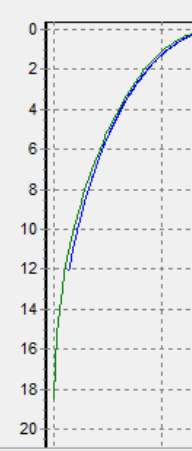
COM number 25 Connected

Disconnect [COM25:]

Device type :	55
Serial number :	8617
Device modification :	85
Measuring range :	67

Voltage : 3,768 V
Temperature : -7,438 °C
Current : -0,203 A

Parameter	Value
Initial position	148
Final position	4670
Time step ->	5
Time step home <-	2
Step size 0,1 micron	3044
Additional constant on an axis X	1731
Corner of turn(Alfa)	70
Correction coefficient(KoefY)	10049
Correction coefficient(Koef1)	-36
Leg size on 10 microns	9736



30.4. Restoring the factory settings

If parameters have incorrect values (negative or zero), it is necessary to restore the factory settings by pressing the **Load Default** button. After that, recalibrate the profilometer.

77

COM number 25 **Connected**

Disconnect [COM25:]

Device type :	55
Serial number :	8617
Device modification :	85
Measuring range :	67

Voltage : 3,768 V
Temperature : -7,438 °C
Current : -0,203 A

Parameter	Value
Initial position	148
Final position	4670
Time step ->	5
Time step home <-	2
Step size 0,1 micron	304
Additional constant on an axis X	173
Corner of turn(Alfa)	70
Correction coefficient(KoefY)	100
Correction coefficient(Koef1)	-36
Leg size on 10 microns	9736

- Write
- Read
- Write All parameters
- Read All parameters
- Write to FLASH
- Load Default**

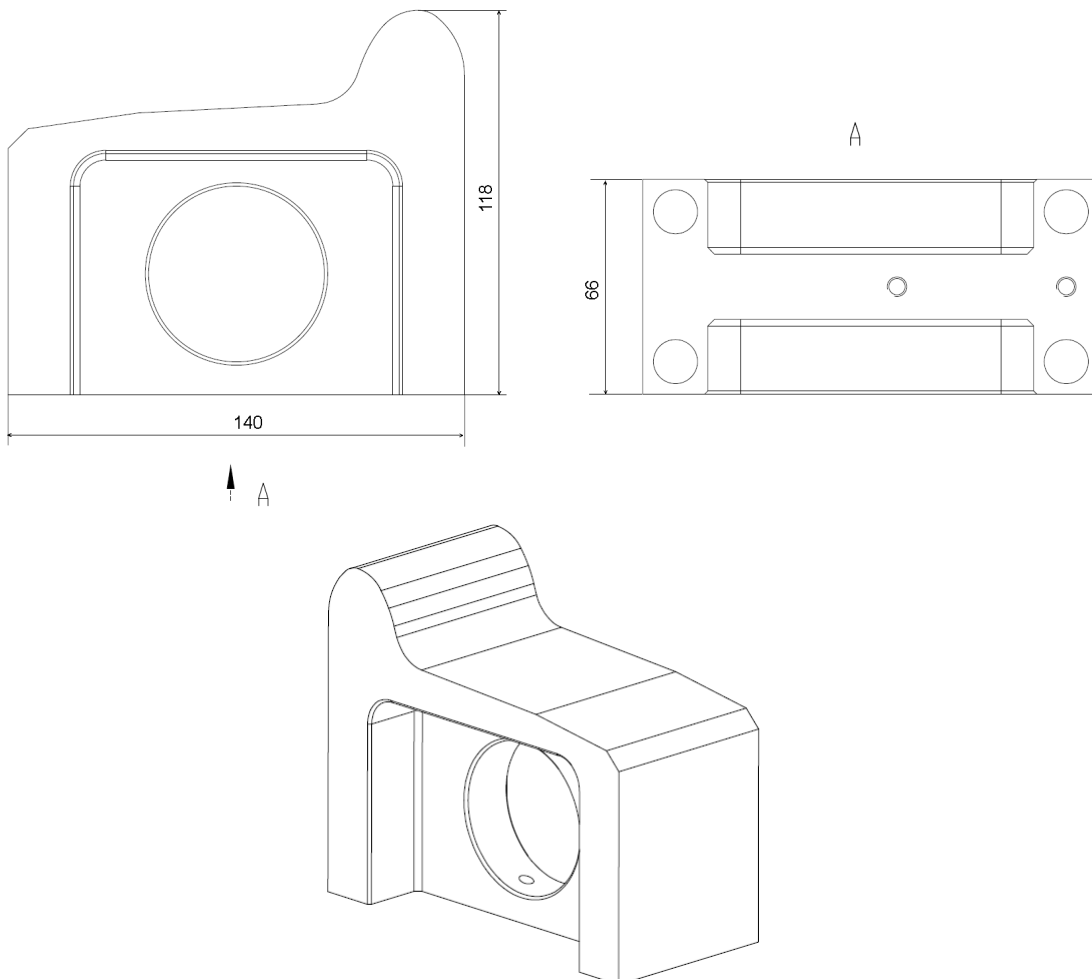


Figure 1A

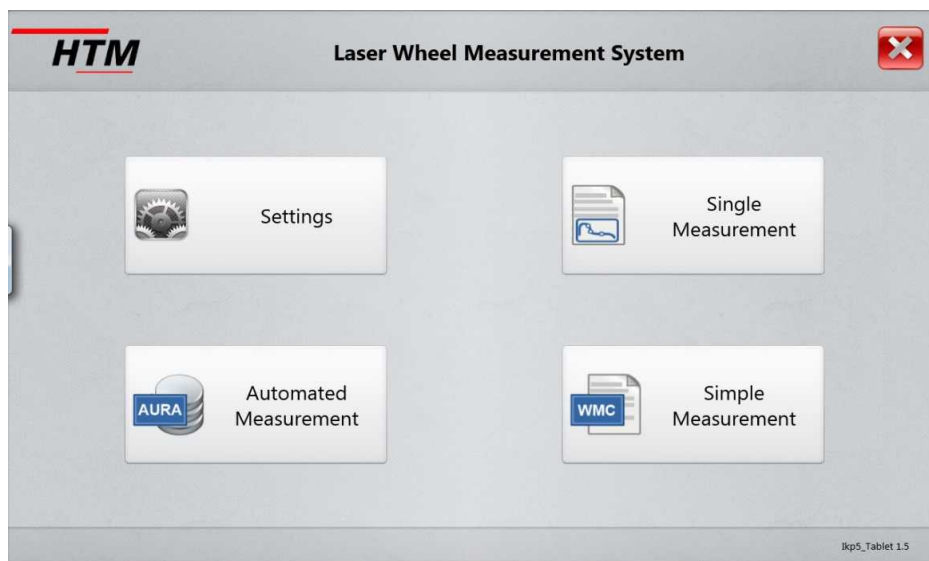
31. Annex 4. Software application for working with the "A.U.R.A. Wheel" system

When working with the **A.U.R.A. Wheel** system from NEM Solutions, the laser scanning module is controlled by the special software application installed on a tablet computer.

31.1. Installation

To install the software, select and run the **lkp5_Tablet.exe** file. Follow the guidelines in dialog boxes of the Installation Wizard. By default, the software will be installed in the following directory – **C:\Program Files (x86)\Riftek, LLC\lkp5_Tablet**.

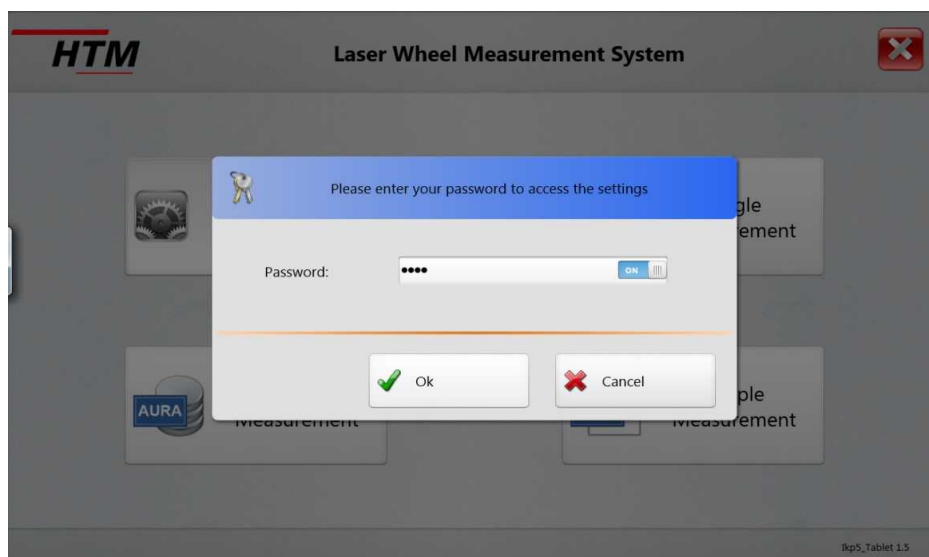
To start the program, press **Start > All programs > Riftek, LLC > lkp5_Tablet > lkp5_Tablet.exe**. The main window is shown below:



31.2. Settings

Before starting to work with the profilometer, it is necessary to configure parameters.

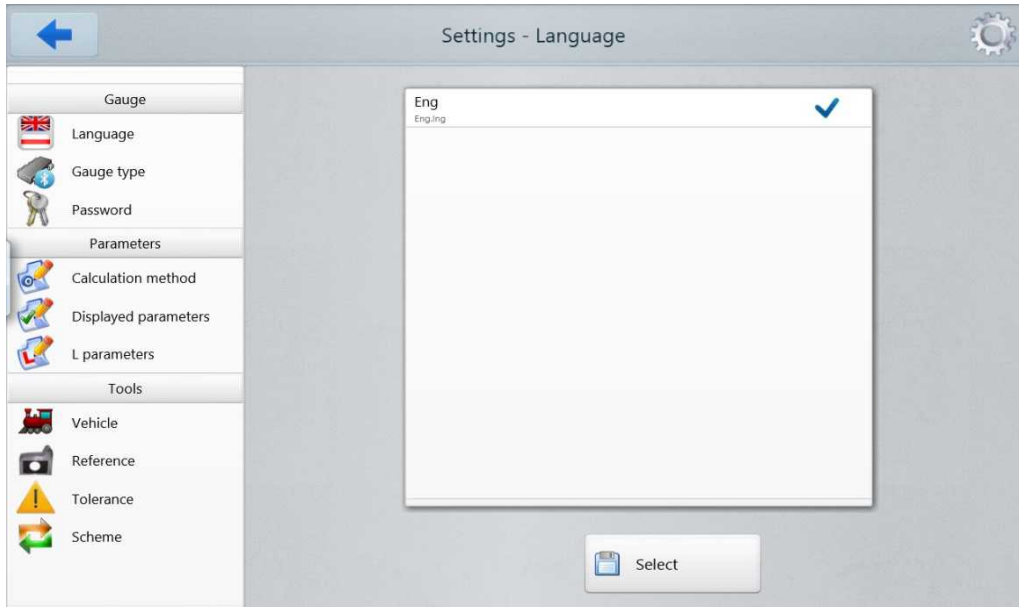
Press the **Settings** button. The program will require a password. When initially installed, the program accepts the following password: 1111. How to change the password, see Par. [31.2.3](#).



Enter the password and press **Ok**. The window of program settings will appear.

31.2.1. Language

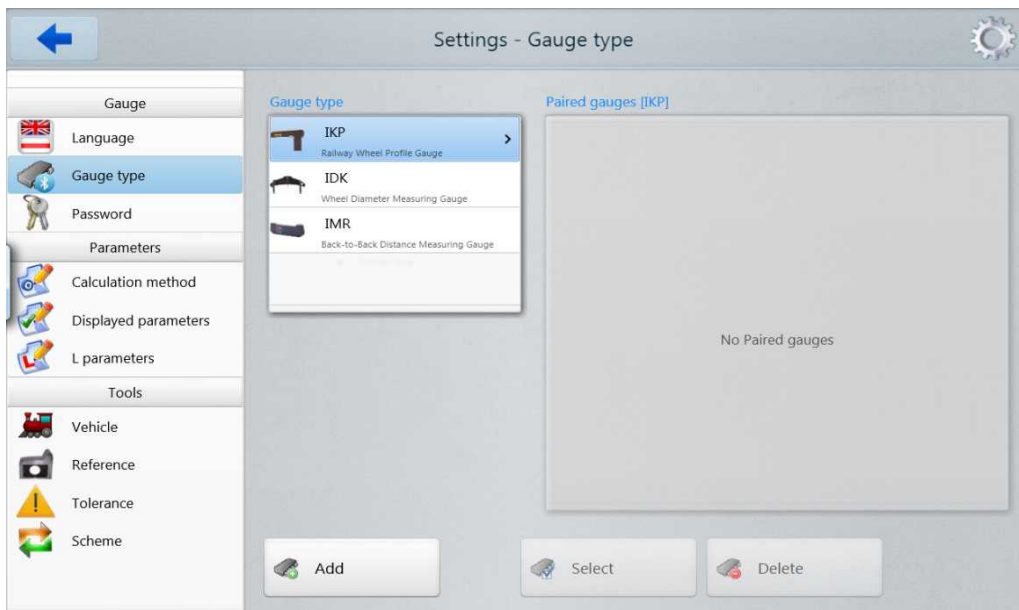
The user can change the language, form his own language support files as well as change/edit the terminology used. To select the language, press **Language**, select the language support file, and press **Select**.



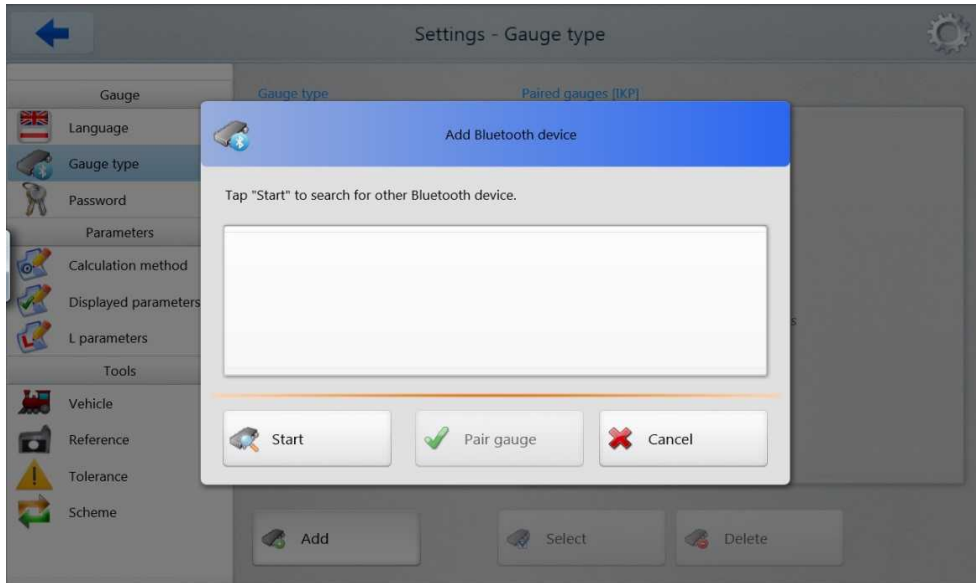
How to create the language support file, see Par. [22.2.4.1](#).

31.2.2. Gauge type selection

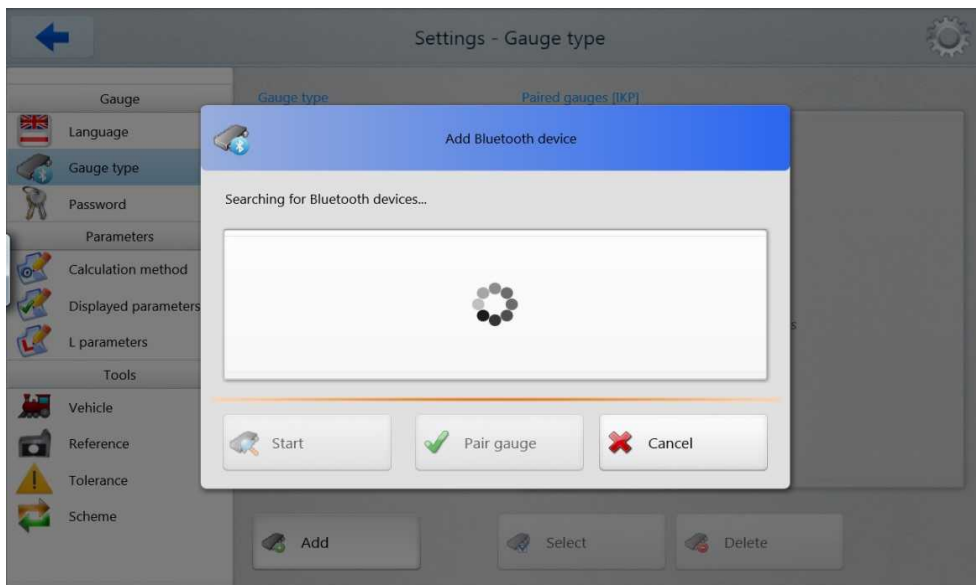
The program allows to work with the following gauges: IKP, IDK, IMR. When selecting one of them, you will see a list of available devices (i.e. devices that have been connected earlier).



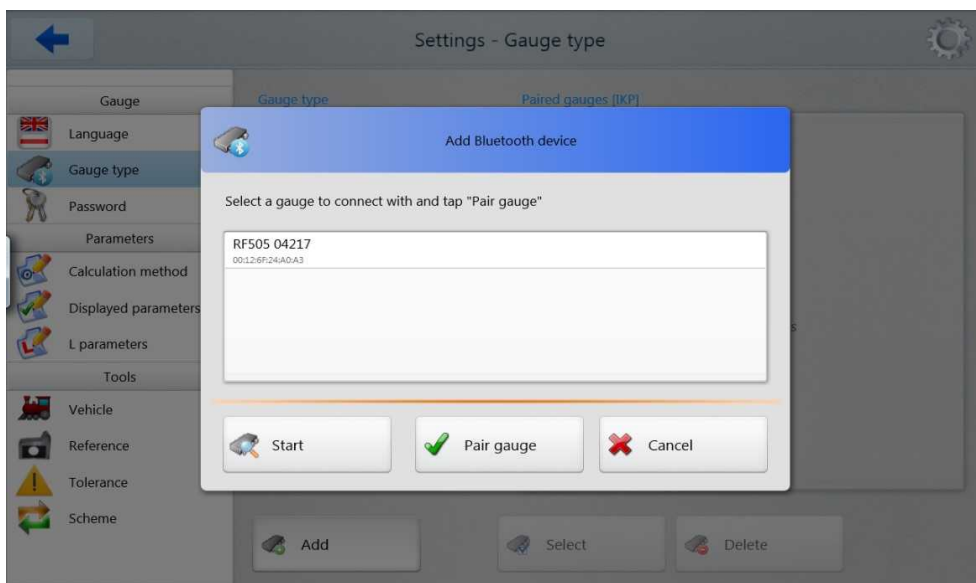
Select the gauge and press the **Select** button. Parameters of the selected gauge will be used to connect to it. If the device is not in the list, you can add it – press the **Add** button and start to search for Bluetooth devices.



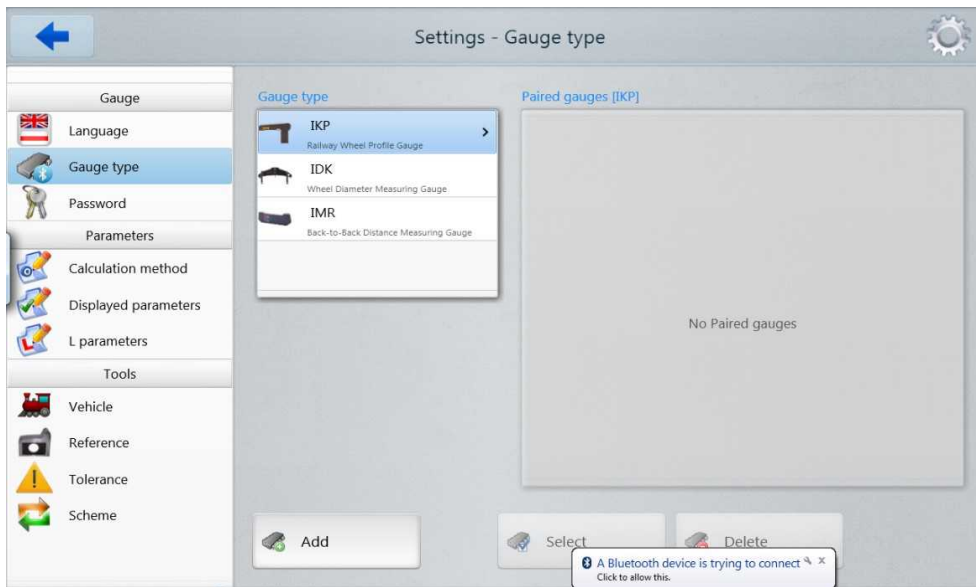
Press **Start** and wait for the search to complete.



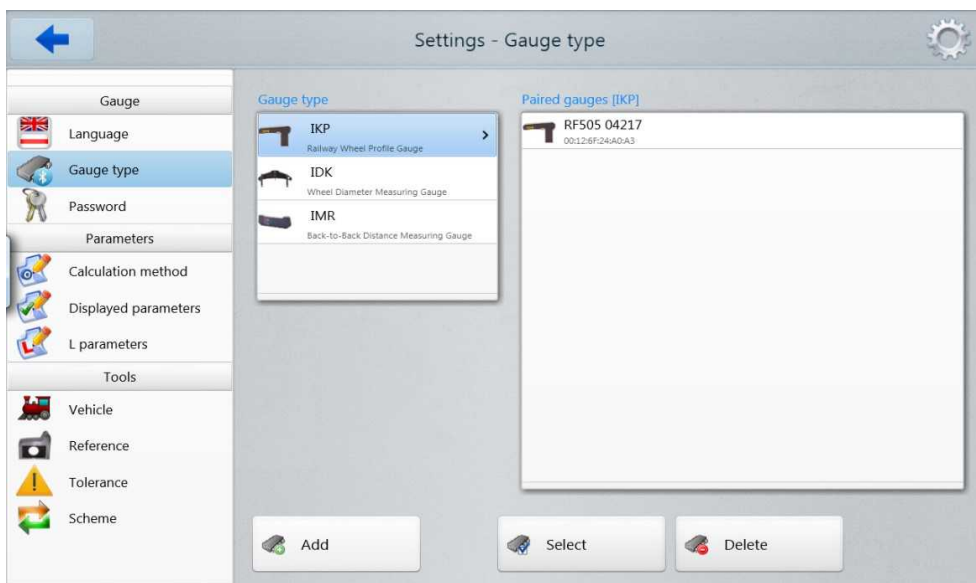
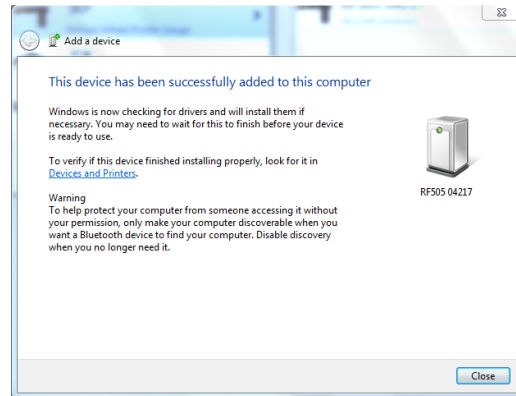
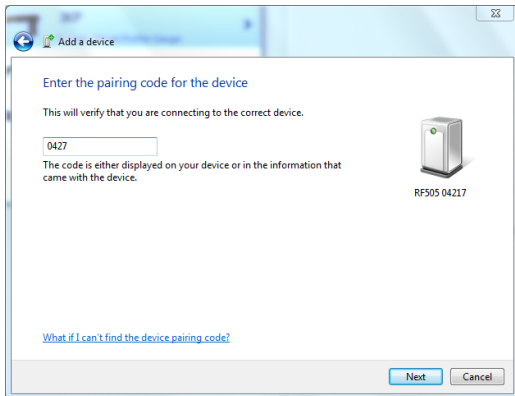
The detected devices with their serial numbers will appear:



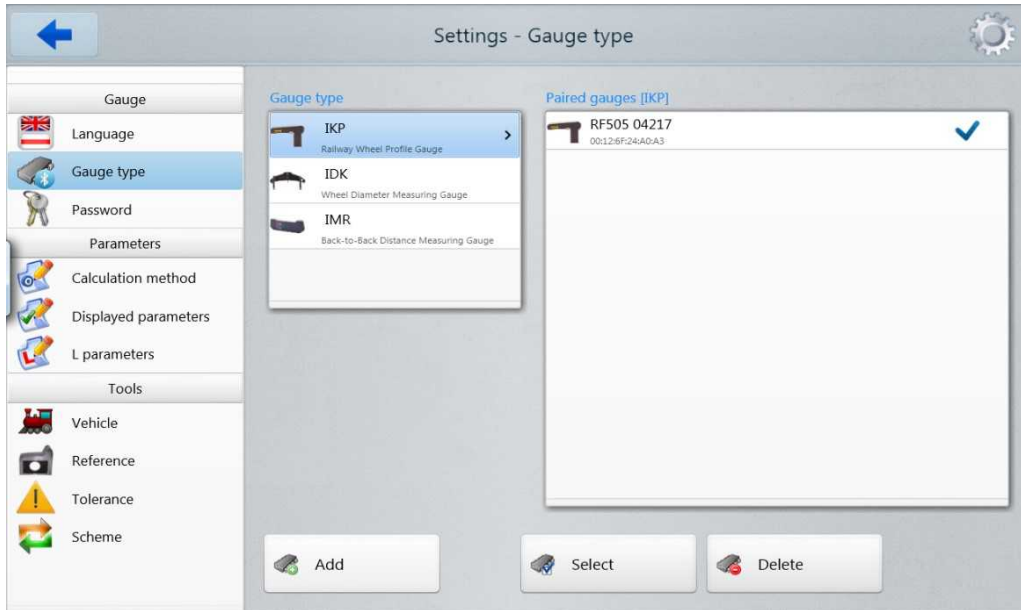
Select the device and press **Pair gauge** to include it in the list. Windows will report an attempt to add a new device, and request a pairing code.



If the pairing code is correct and the device is successfully added, the system will display a message. The device installation may take some time. The pairing code for each device consists of 4 symbols and is formed according to a serial number. For example, if a serial number is 04217, then a code will be 0427; if a serial number is 01317, then a code will be 0137, etc.



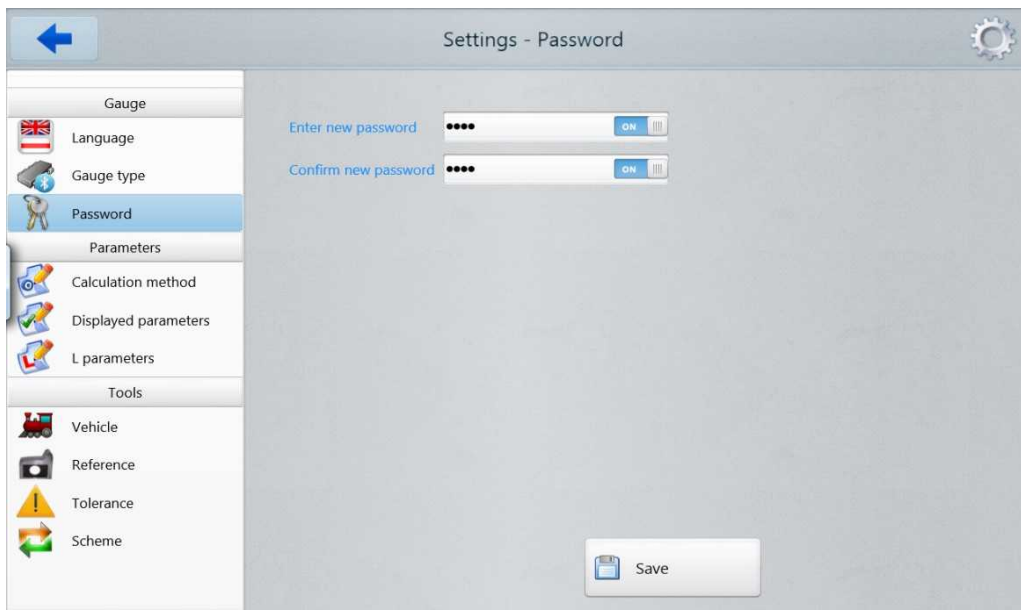
Select the device by pressing the **Select** button.



If you do not use the device anymore, you can delete it by pressing the **Delete** button. Similarly, you can add other gauges (IDK and IMR).

31.2.3. Password

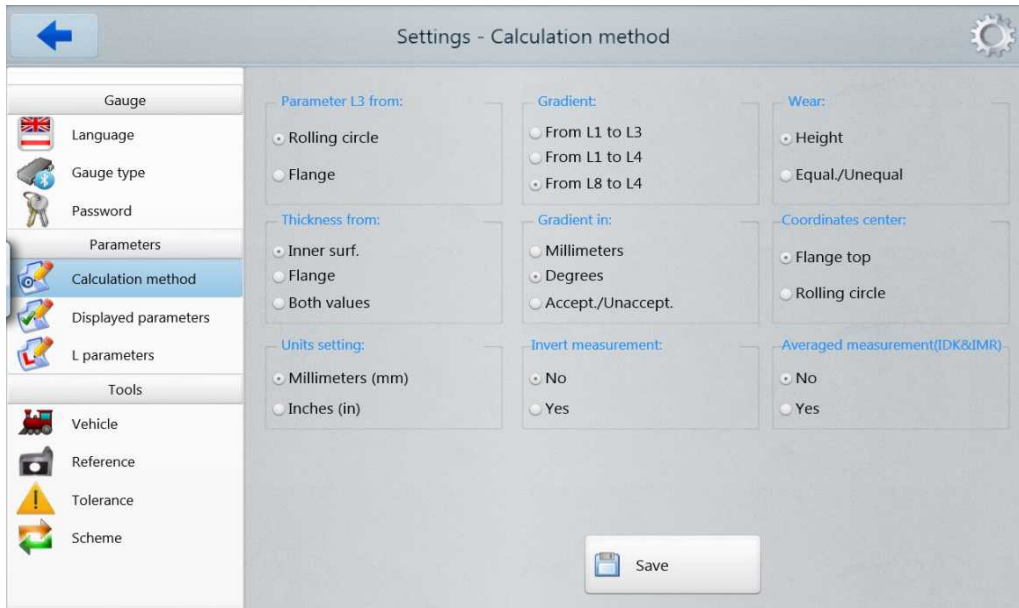
To change the password, press **Password**.



Enter a new password, confirm it, and press **Save**.

31.2.4. Calculation methods

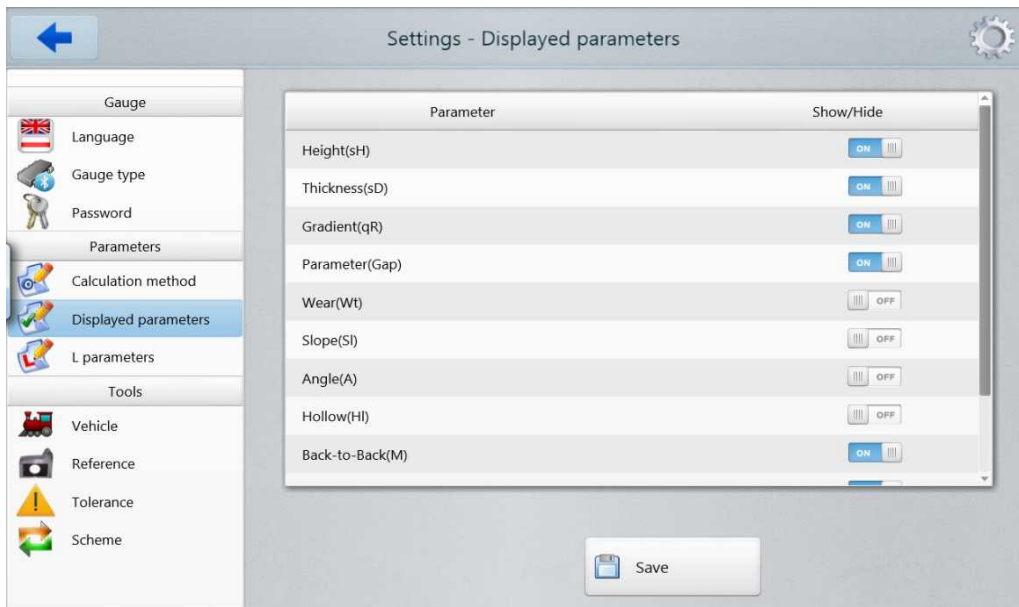
Press **Calculation method**. On the screen:



To save the changes, press **Save**.

31.2.5. Selection of displayed parameters

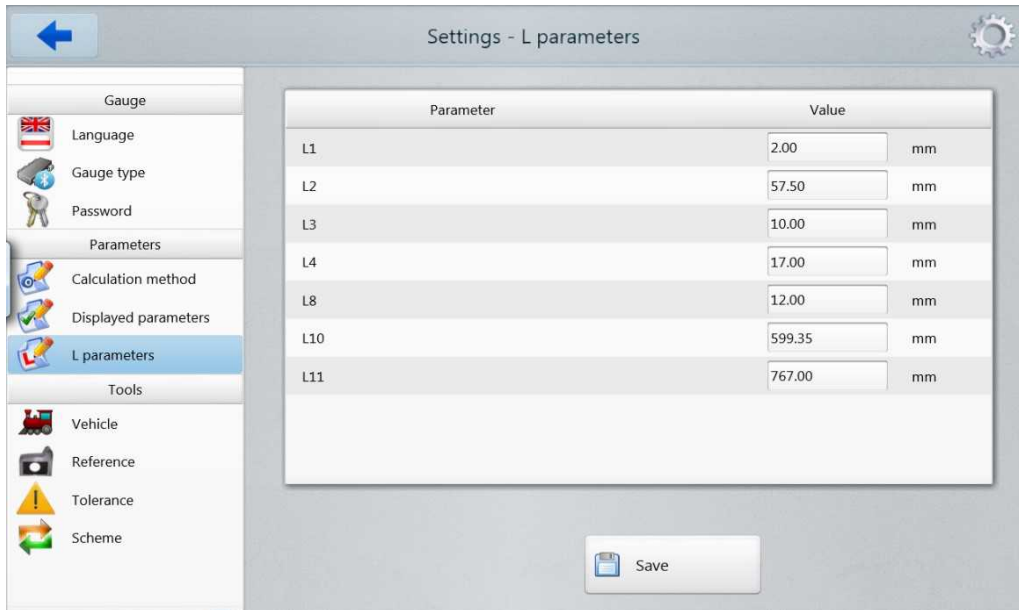
Press **Displayed parameters**. On the screen:



In order to select/deselect a parameter, set **ON/OFF** in the **Show/Hide** column. To save the changes, press **Save**.

31.2.6. L-parameters

Press **L parameters**. The table displays only those L-parameters that are necessary to calculate the selected geometrical parameters of the wheel.



To save the changes, press **Save**.

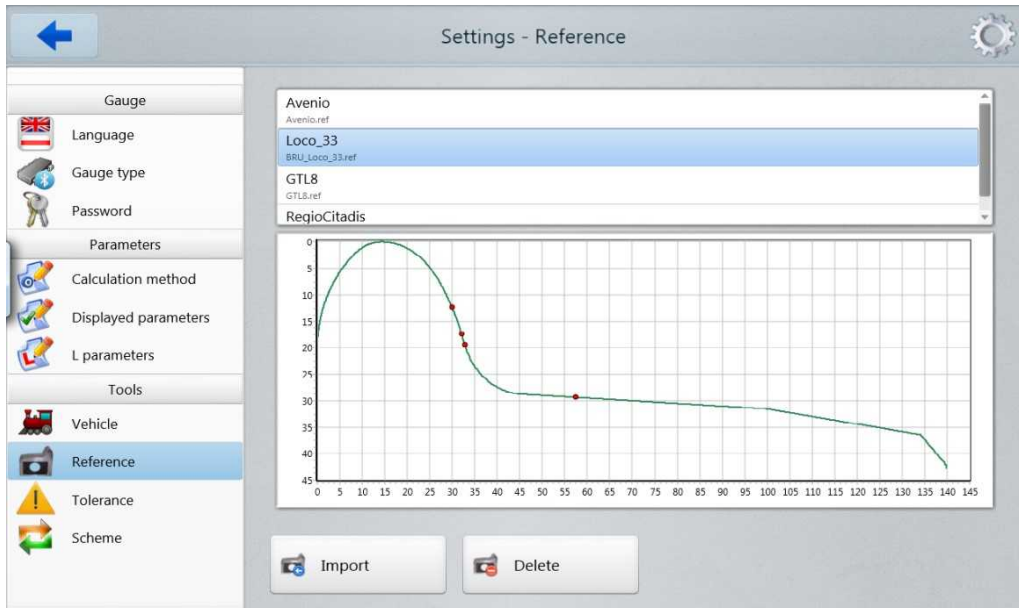
31.2.6.1. Preset values

L-parameter	Default value	Assignment
L1	2 mm	Used for calculation of the flange slope (qR)
L2	70 mm	Defines position of the wheel rolling circle, and used for calculation: - flange height (sH) - flange thickness (sD) - flange slope (qR) - inclination angle (A) - wheel diameter (D) - rim thickness (T) - wear (Wt, Wf, Wr)
L3	13 mm	Used for calculation: - flange thickness (sD) - flange slope (qR) - wear (Wf)
L4	13 mm	An additional point for calculation of the flange slope (qR)
L5	10 mm	Used for calculation of an angular wear (Wr)
L6	70 mm	Used for calculation of slope of the rolling surface section (S1)
L7	105 mm	Used for calculation of slope of the rolling surface section (S2)
L8	10 mm	Used for measurement of the profile inclination angle at the required point (A)
L9	140 mm	Used for inverting the measurement direction (L9 – profile width)
L10	599,35 mm	Used for calculation of the profile diameter (D)
L11	767 mm	Used for calculation of the reference profile rim thickness (T)
L15	13 mm	Used for calculation of the flange thickness of tram wheels (sD15)

P7_1	50 mm	Used for calculation of the hollow (HI)
P7_2	105 mm	
P8_1	110 mm	
P8_2	130 mm	
D1	70 mm	Used for calculation of the hollow (HI)
D2	107,5 mm	

31.2.7. Reference profile selection and installation

The program allows to compare the scanned profile of the wheel with the reference profile. To select the reference profile, press **Reference**.



To delete the reference file, activate the line and press **Delete**.
To add the reference file, press **Import** and select the *.ref file.

31.2.7.1. Writing the reference profile to the database

Reference profiles are stored in the database as profile description files with the .ref extension. The software is supplied with several preset profiles.

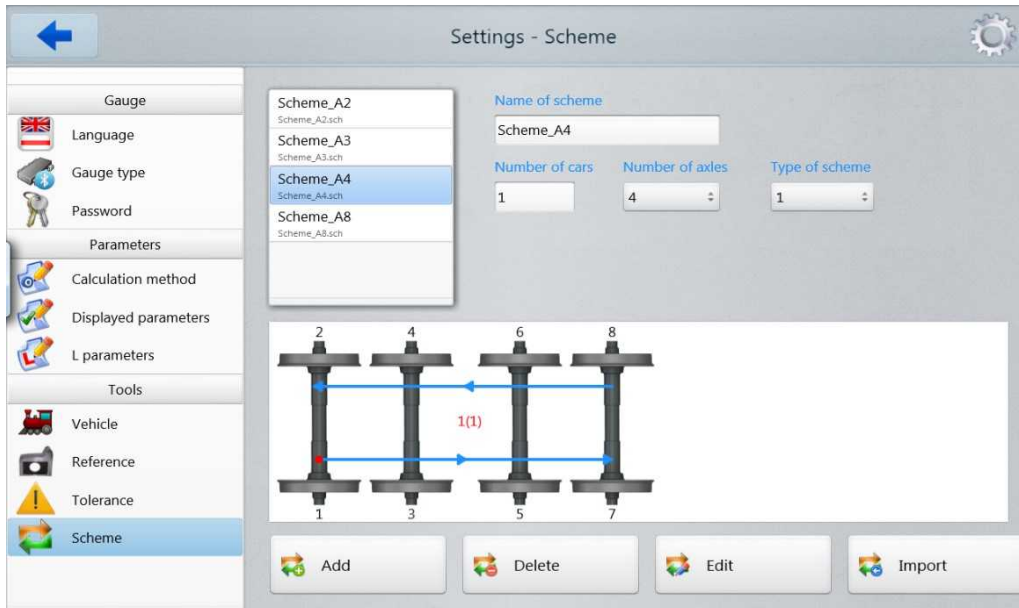
If there is no required reference profile in the database, the user can request the missing profile from **RIFTEK** (free service).

31.2.8. Measurement scheme

The measurement scheme is meant as a sequence of making measurements/processing of wheels in the rolling stock with specified parameters of each wheelset (wheelset numbers, car numbers, series, etc.). The program automatically offers the operator to perform measurement of the wheel in accordance with selected scheme of wheel processing. The program contains several preset schemes. Besides, the user can form his own measurement scheme.

31.2.8.1. Selection or removal of the measurement scheme

To select the measurement scheme file, press **Scheme**.



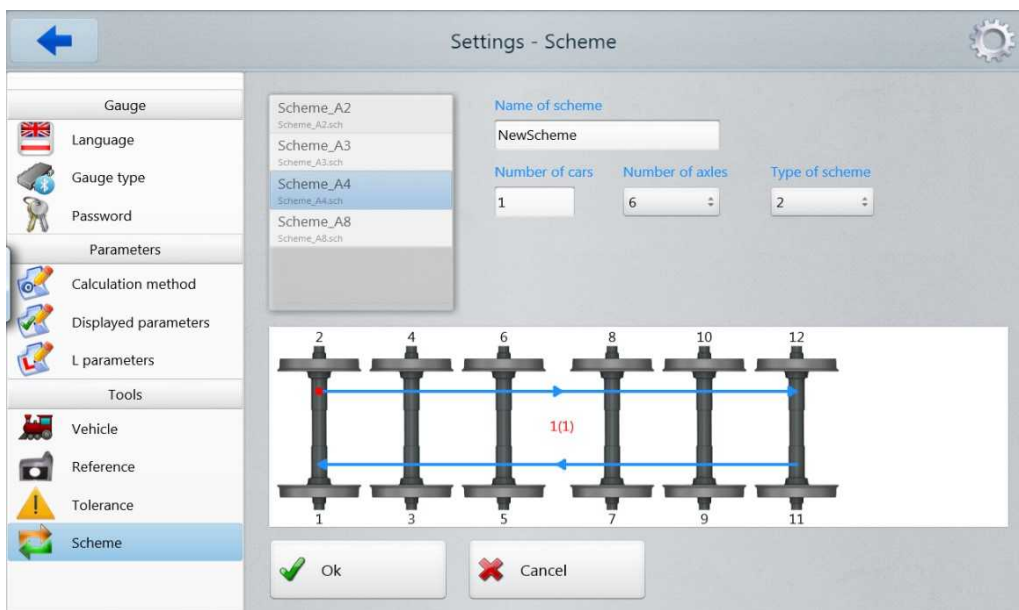
Arrows in the figure show the direction of processing of wheelsets as well as the names assigned to wheels.

To delete the scheme file, activate the line and press **Delete**. If you delete the current scheme, the error message will appear.

To add the scheme file, press **Import** and select the *.sch file.

31.2.8.2. Formation of a new measurement scheme

To form a new measurement scheme, press **Add**. The following window will appear:



Next:

- enter the scheme name;
- select the number of cars;
- select the number of axes;
- select the wheel processing scheme out of the options suggested;

- press **Ok**.

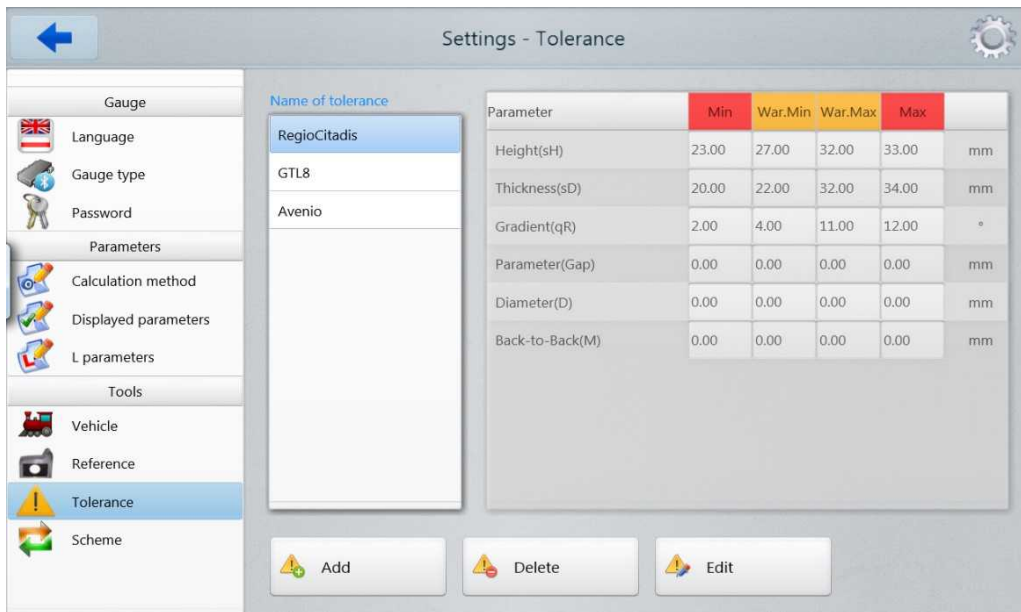
This method of the measurement scheme formation allows to create only simple schemes without specifying the wheelset numbers, car numbers, series, etc. To form a complete scheme, see par. [29](#).

31.2.9. Tolerances

The program automatically controls measured geometric parameters for going out beyond the tolerances set. It is possible for the user to create groups of tolerances. Control of parameters will be performed for a selected group.

To select a current group of tolerances, press **Tolerance**. The table will show tolerances only for the selected geometric parameters of the wheel.

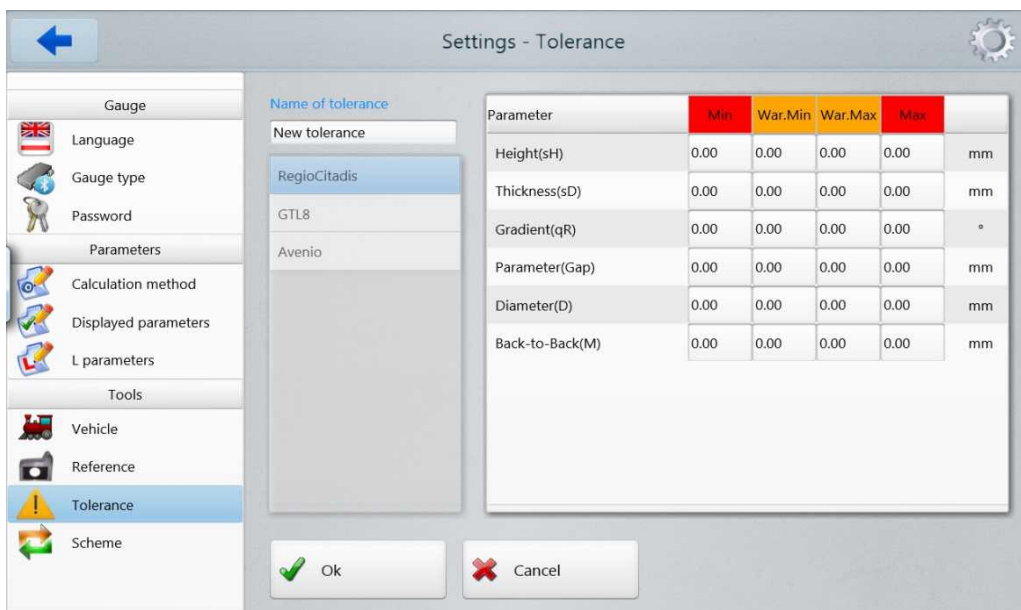
A red color indicates the maximum/minimum critical values of parameters. An orange color indicates the maximum/minimum values, which are close to critical values.



To delete the tolerance, activate the line and press **Delete**.

To edit the tolerance, activate the line and press **Edit**.

To add a new tolerance, activate the line and press **Add**. On the screen:



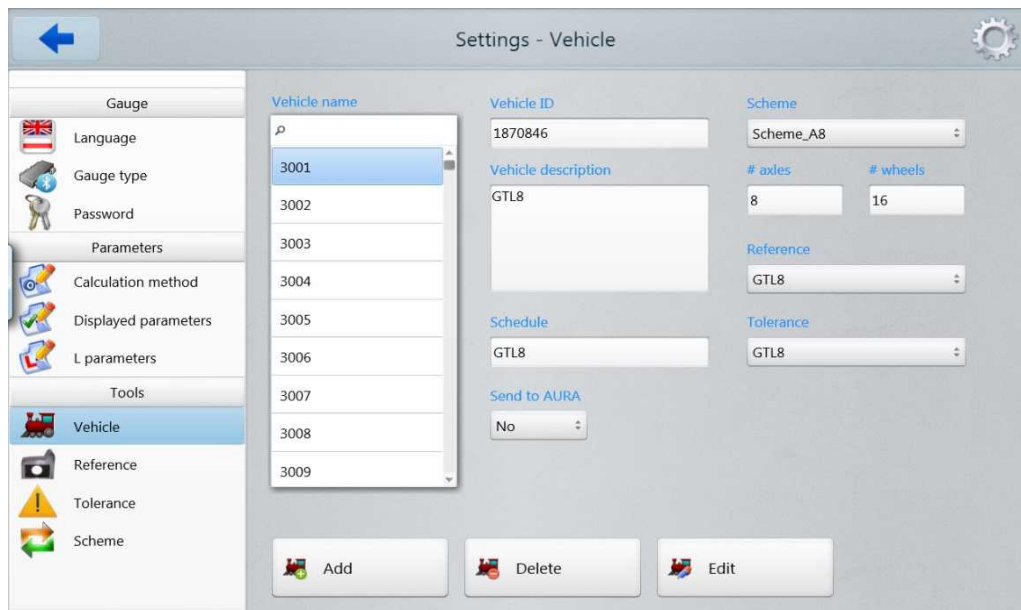
Enter the tolerance name into the **Name of tolerance** field and the values into the **Min/War.Min/War.Max/Max** fields. To save the changes, press **Save**.

31.2.10. Vehicles

To view a list of rolling stocks, press **Vehicle**. The listed rolling stocks can be selected for measurement.

Parameters of the rolling stocks:

Vehicle name	Name of the rolling stock
Vehicle Id	Identification number of the rolling stock
Vehicle description	Description of the rolling stock
Schedule	Schedule for the rolling stock
Send to AURA	Select "Yes" if you want to send data to the AURA database, or select "No" if you don't
Scheme	Measurement scheme name
# axles	Number of axles
# wheels	Number of wheels
Reference	Reference name from a list of references (Reference tab)
Tolerance	Tolerance name from a list of tolerances (Tolerance tab)



To delete the rolling stock, activate the line and press **Delete**.

To edit the rolling stock, activate the line and press **Edit**.

To add a new rolling stock, activate the line and press **Add**.

31.3. Measurements

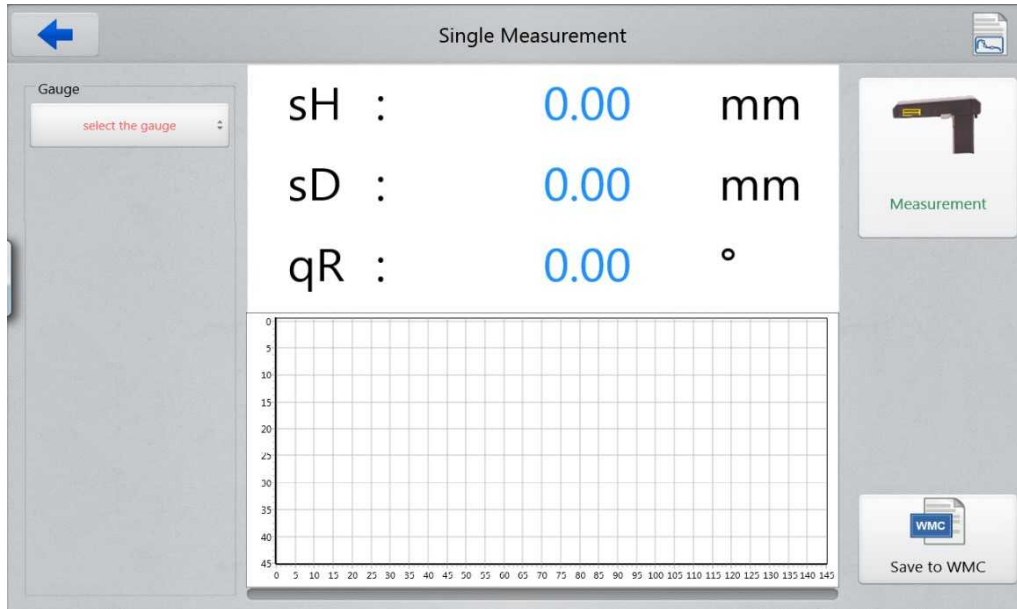
There are three types of measurements:

1. Single Measurement – measurement without specifying the rolling stock type, measurement scheme, tolerances. Measurement results can be saved to the WMC format.
2. Simple Measurement – measurement of the selected rolling stock with specifying the scheme and tolerances. Measurement results are saved to the WMC format.

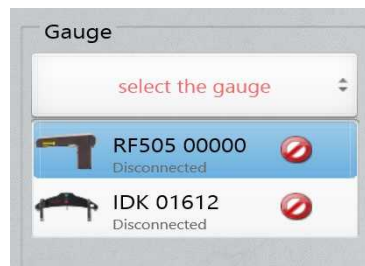
- Automated Measurement – measurement of the selected rolling stock with specifying the scheme and tolerances. Measurement results are transferred to the AURA database.

31.3.1. Single measurement

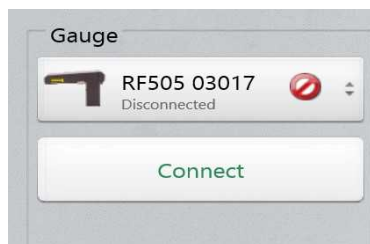
To enter the mode, press the **Single Measurement** button.



First, you need to establish the Bluetooth connection to the gauge: IKP, IDK or IMR.

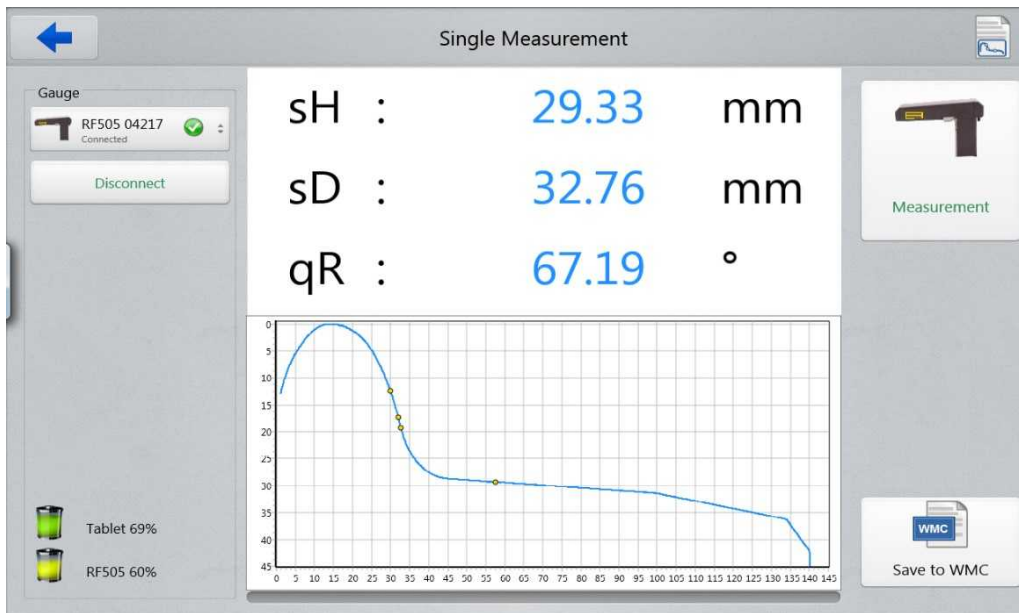


The list contains devices selected in settings (see Par. [31.2.2](#). "Gauge type selection"). After selecting, press the **Connect** button.



The **Measurement** button and the charging indicators will be active.

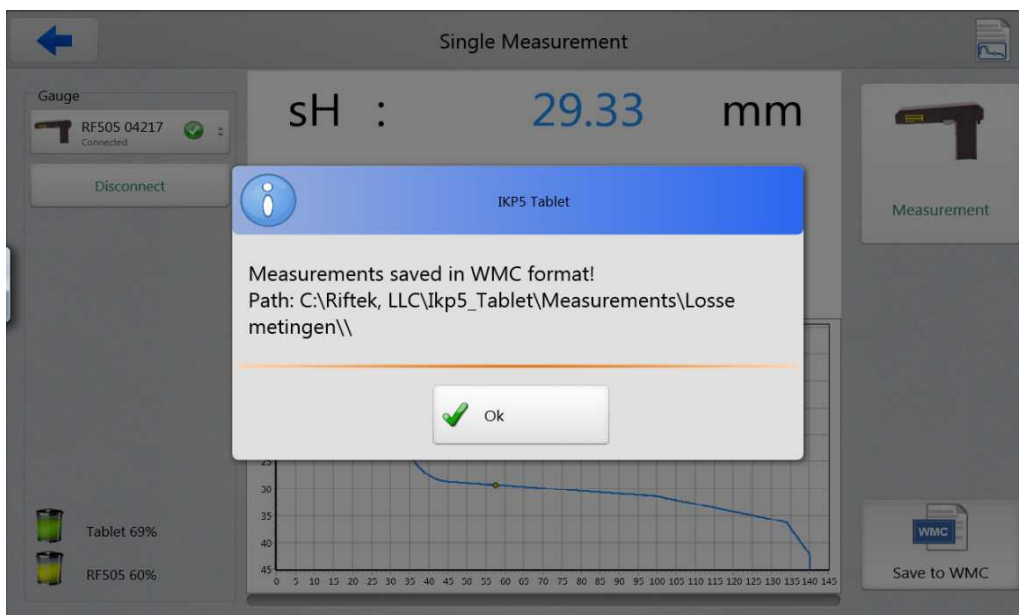
- Press the **Measurement** button.
- After pressing the **Measurement** button, the laser module starts scanning of the wheel surface. During the scanning process (1-2 seconds), a red LED is lit.
- When the scanning process is complete, the program displays the measurement results.



90

Measurement results and profile coordinates can be saved to the file of the WMC format. The files are saved to the following directory:

C:\Riftek,LLC\Ikp5_Tablet\Measurements\Losse metingen



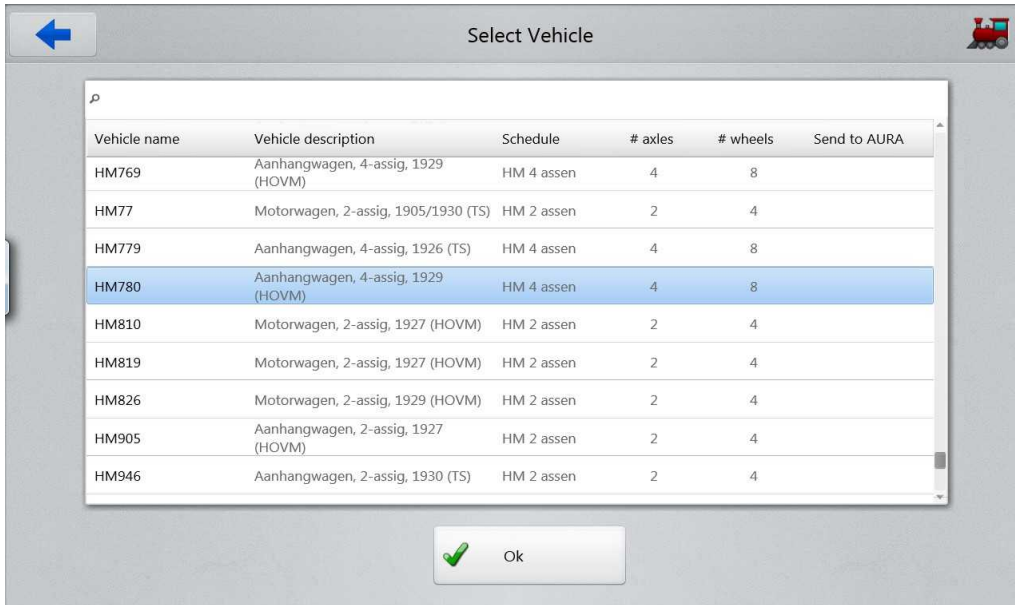
The IDK is designed to measure the wheel diameter. The IMR is designed to measure the back-to-back distance. In order to change the gauge type, press the **Disconnect** button, select the gauge you need, and press **Connect**.

The measurement procedure is similar to IKP.

31.3.2. Simple measurement

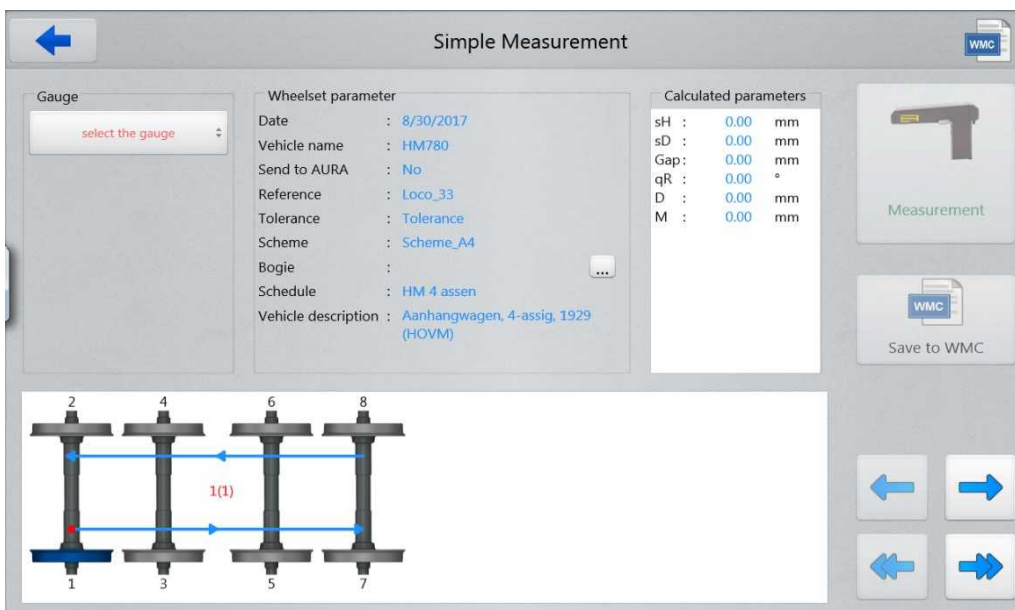
To enter the mode, press the **Simple Measurement** button. This mode allows to perform measurements in accordance with the rolling stock parameters (scheme, tolerances, reference).

First, you need to select the rolling stock in the **Select Vehicle** window. The list contains only those rolling stocks, the measurement results of which will not be sent to the AURA database (the **Send to AURA** column is empty).



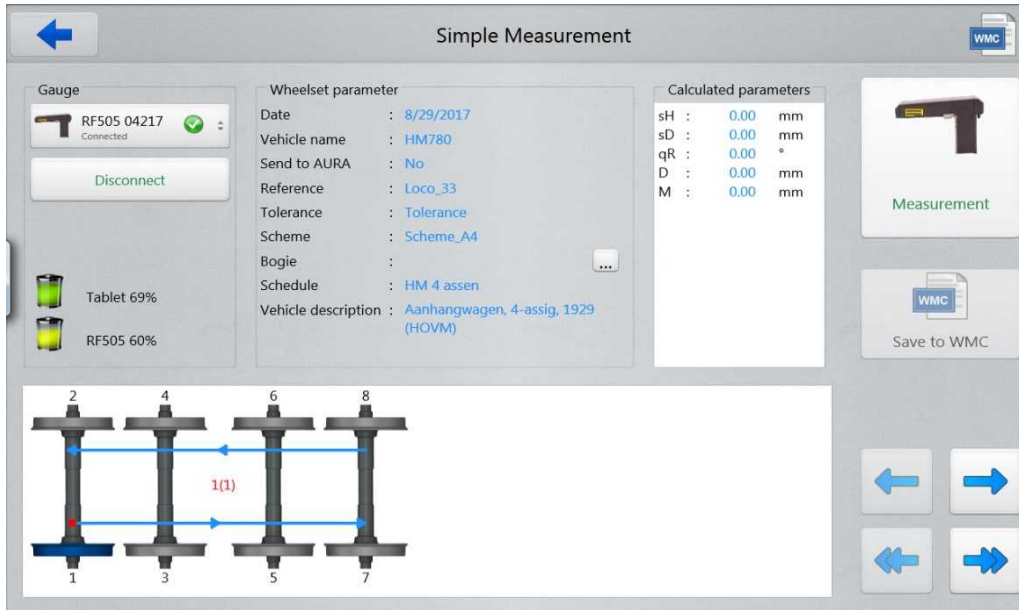
Select the rolling stock (or specify its name in the search line) and press **OK**.

The program will show the measurement scheme and parameters for the selected rolling stock.












Next, select and connect the gauge: IKP, IDK or IMR. The connection procedure is described in the previous paragraph.

When the connection is established, the **Measurement** button will be active and you can start measurements.

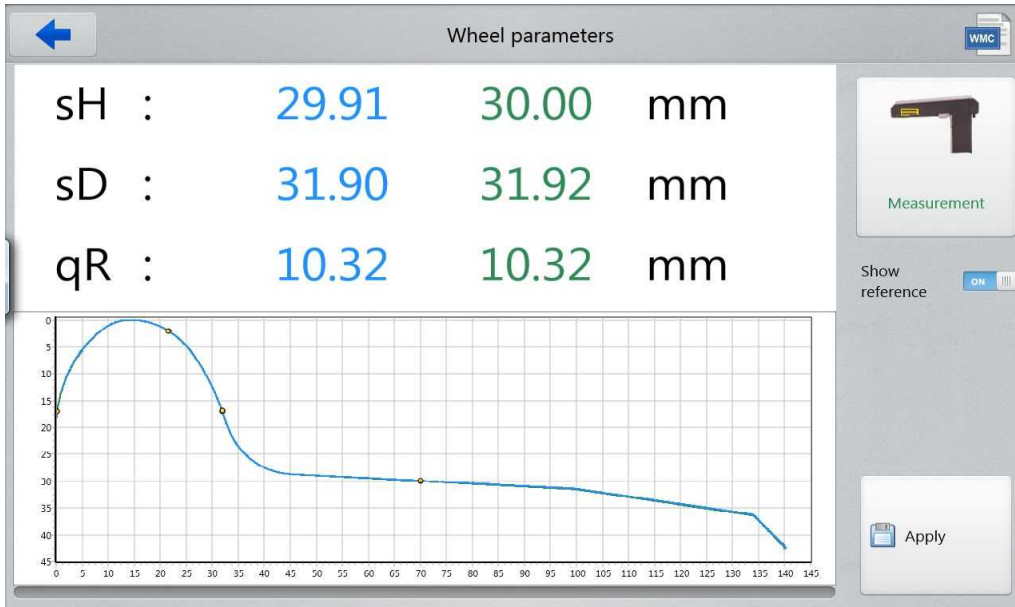


Designations and buttons:

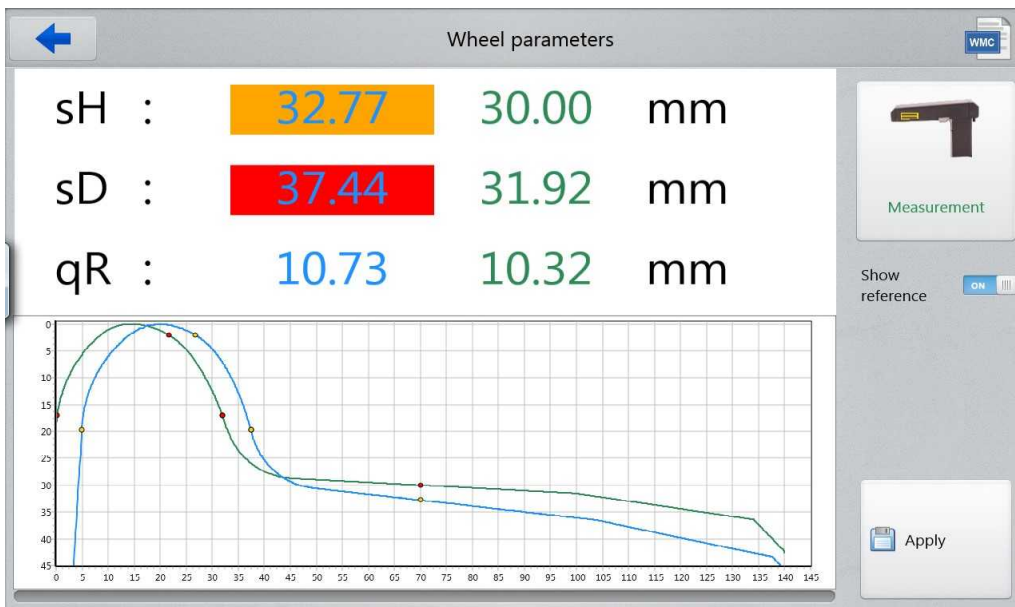
	an ordinal number of the car to be measured (number of cars in the rolling stock)
	pass to the previous/next wheel
	pass to the previous/next car
	a measured wheel
	a wheel to be measured the next time
	a non-measured wheel
	parameters of the measured wheel are beyond the tolerances
	parameters of the measured wheel are close to the tolerances
	measurement

31.3.2.1. Measurement

- Press the **Measurement** button in order to measure the wheel offered by the program (highlighted in green). The laser module will scan the wheel surface.
- Upon completion of the scanning process, the program will show the values of selected geometrical parameters.

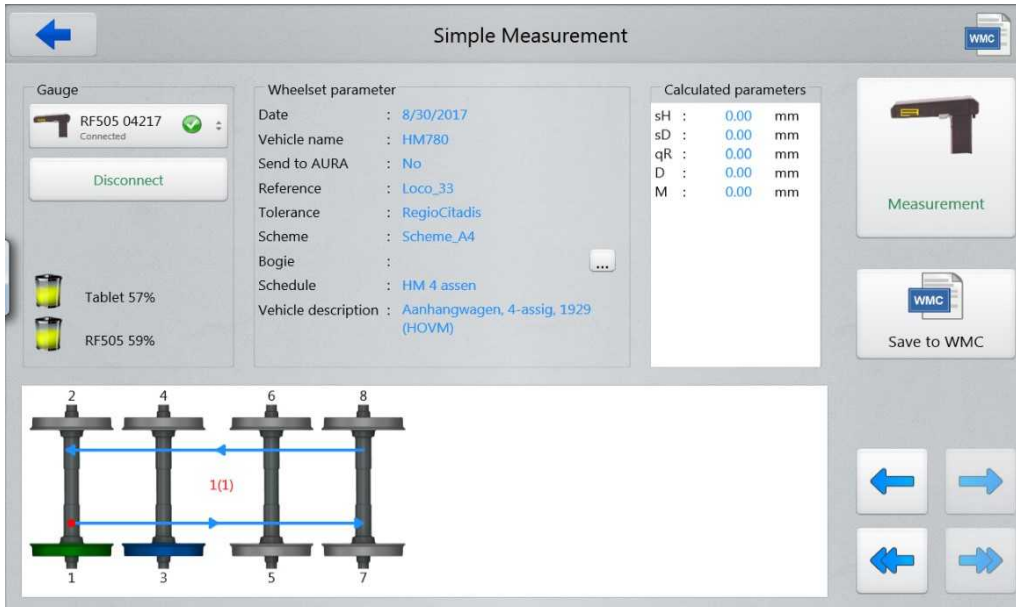


When the value is beyond the tolerances, it will be highlighted in red:

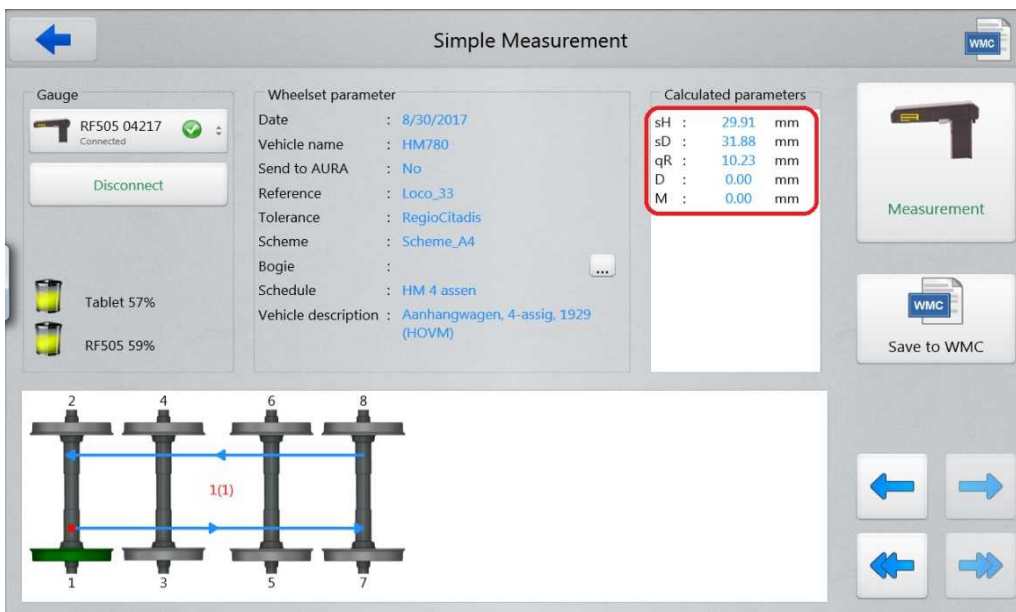


The program allows to display only parameters of the measured profile. To hide the reference values, you need to disable the **Show Reference** option (select "Off").

- To repeat the measurement, press the **Measurement** button.
- When a satisfactory result is obtained, press the **Save** button to save it.
- The program will offer to pass to the measurement of the next wheel in accordance with the selected scheme of measurement.



- To view the results of previous measurements, you can use the arrows. If you select the measured wheel, the program will display the saved wheel parameters.

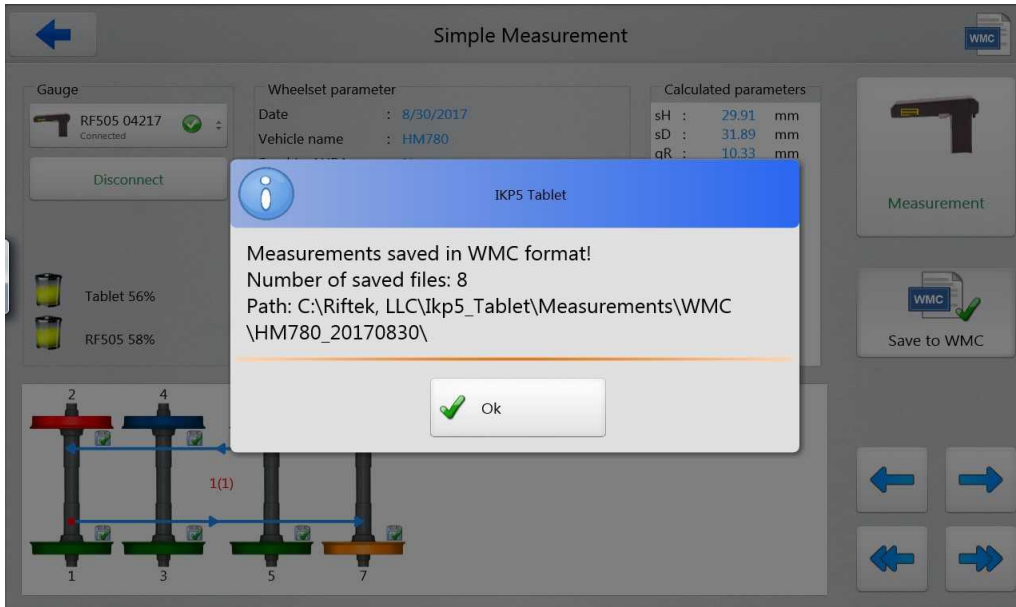


- When you measure the wheel that was already measured, the program prompts you to replace the existing values with the new ones.

The measurement results can be saved in the WMC format. Each measurement is saved in a separate file. The path:

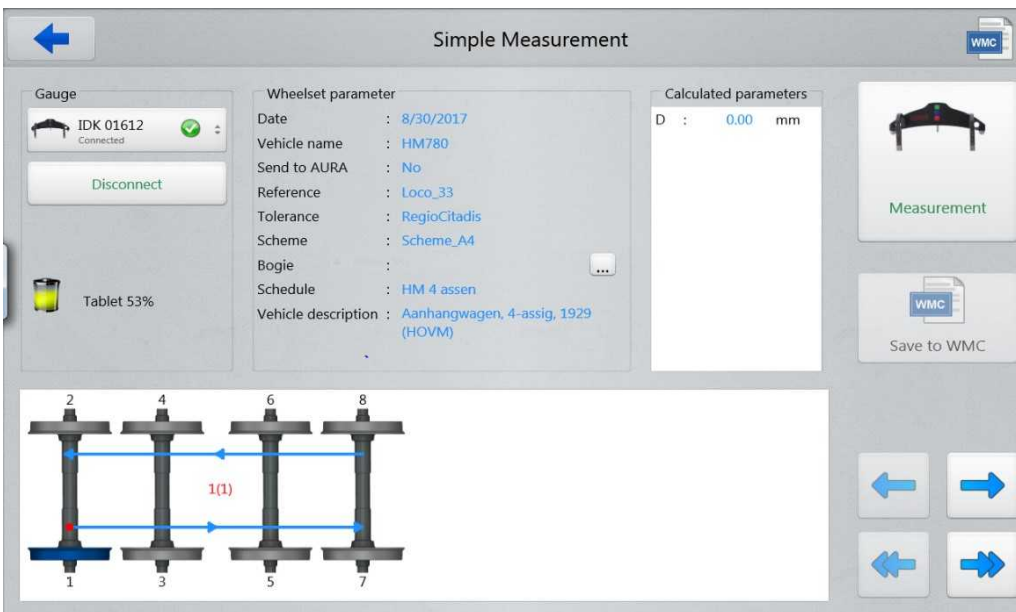
C:\Riftek LLC\Ikp5_Tablet\Measurements\WMC\HM780_20170830

Where **HM780_20170830** is the directory name, **HM780** is the rolling stock name, **20170830** is the date of measurement (yyyymmdd).

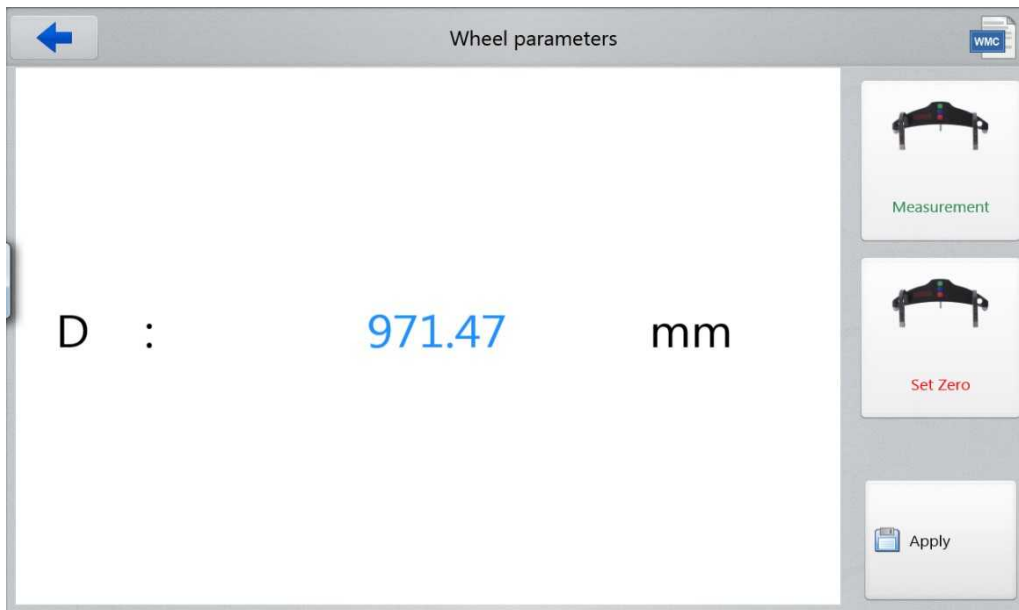


31.3.2.2. Measuring by IDK, IMR

To measure the wheel diameter and back-to-back distance, disconnect from IKP by pressing the **Disconnect** button, and select the gauge you need: IDK (to measure the wheel diameter), or IMR (to measure the back-to-back distance).



The measurement process is similar to IKP.




The measurement results can be saved in the WMC format. Each measurement is saved in a separate file.

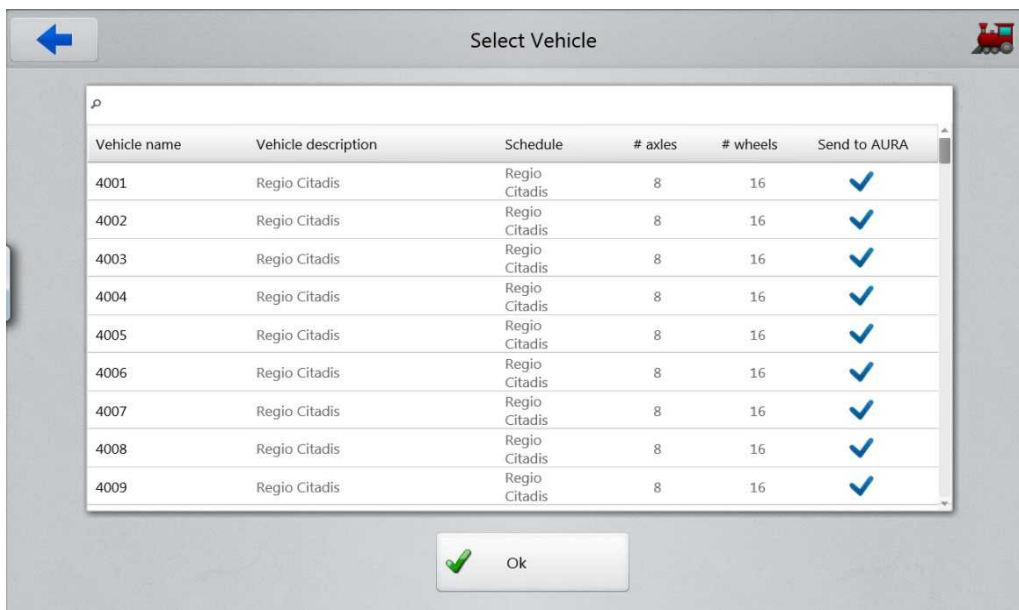
31.3.3. Automated measurement

The **Automated Measurement** mode as well as the **Simple Measurement** mode allows to perform measurements in accordance with the rolling stock parameters (scheme, tolerances, reference).

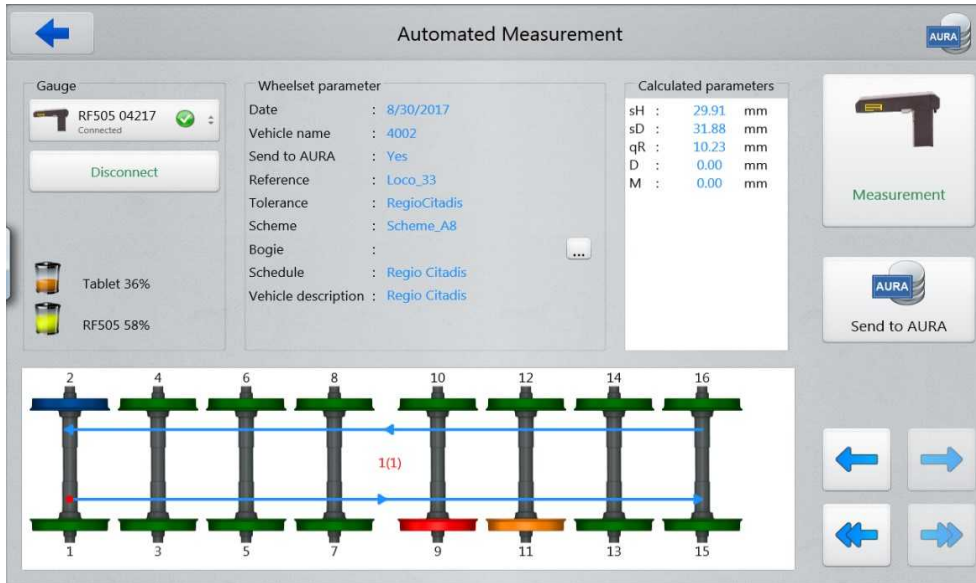
The only difference is that the list contains only those rolling stocks, the measurement results of which will be imported to the AURA database (the **Send to AURA** column is ticked).



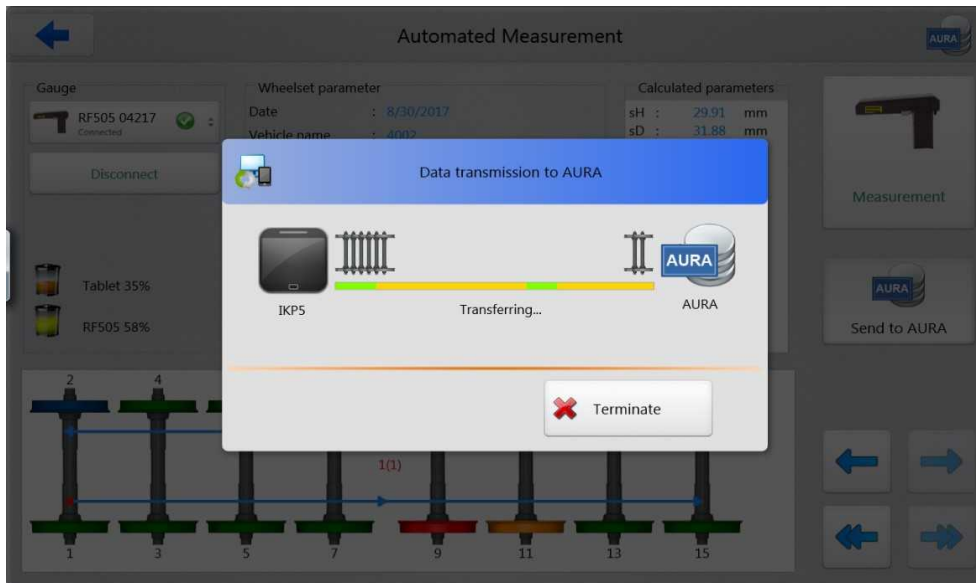
Attention! The Internet connection is required in order to connect to the AURA database and to transmit data.



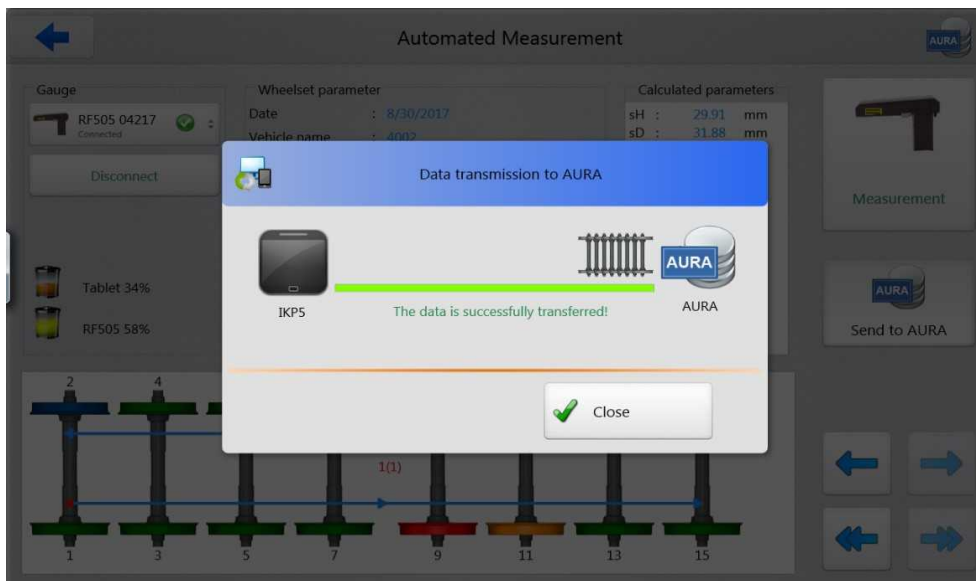
The measurement procedure has one difference from the **Simple Measurement** mode. In order to import data to the AURA database, it is necessary to measure all cars of the selected rolling stock according to the measurement scheme. Only in this case the **Send to AURA** button will be active.



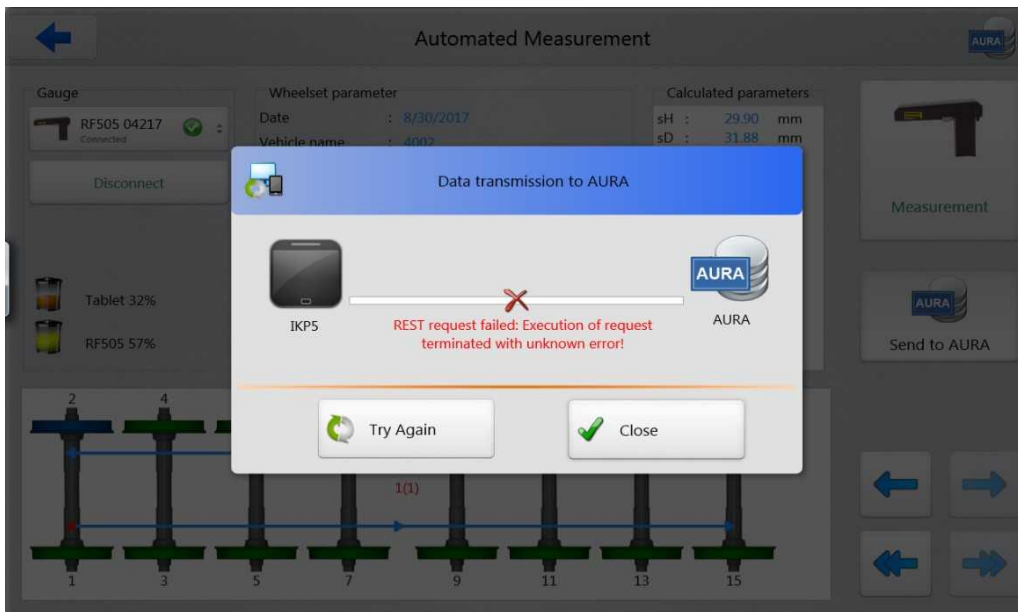
After pressing the **Send to AURA** button, the data transmission window appears. In case of successful identification in the AURA system, the data transmission starts.



When the data is successfully transferred, the following message appears:



If any error occurs while connecting to the AURA system (for example, if there is no Internet connection), the error message appears.



In this case, you need to check the Internet connection and try to transmit data again by pressing the **Try Again** button.

To avoid the data loss, all measurement results are also copied to the directory:

C:\Riftek LLC\Ikp5_Tablet\Measurements\ AURA\4002_20170830

Where **4002_20170830** is the directory name, **4002** is the rolling stock name, **20170830** is the date of measurement (yyymmdd).

32. Warranty policy

Warranty assurance for the Laser Profilometer – 24 months from the date of putting in operation; warranty shelf-life – 12 months.

33. List of changes

Date	Revision	Description
17.05.2017	1.0.0	Starting document.
10.11.2017	1.1.0	Added section 31 'Software application for working with the A.U.R.A. Wheel system'.