

MEDENUS

Gas Pressure Regulation



Gas pressure regulator RS 254 / RS 255

Product information

EN

Table of Contents

Application, Characteristics, Technical Data	4
Application	4
Characteristics	4
Type of model (options)	4
Technical Data	5
Design and function	6
Selection	8
Calculation of the required K_G value	8
Device selection	8
Checking the gas velocities	8
Order data	9
Calculation of the required K_G value	10
RE - Control unit	10
Control unit setpoint spring table	11
Setpoint spring table - SSV	12
Dimensions, Connection and Weight	13
Dimensional drawing	13
Dimensions and weight	13
Option	14
Contact	16
Notes	18



ATTENTION

For installation, commissioning and maintenance are the following documents to note:

DVGW worksheets G 491 and G 600

Operating and Maintenance Instructions RS 254

List of abbreviations and formula symbols

AC	Accuracy class	PS	Maximum allowable pressure	(SSV)	
AG _o	Upper response pressure group	p _u	Inlet pressure	ΔpW _{dso}	Min. re-engagement difference between upper response pressure and normal operating pressure
AG _u	Lower response pressure group	Q _n	Standard volumetric flow rate		
HDS	High-pressure screw spindle value	RE	Control unit		
K _G		BV	Breather valve	ΔpW _{dsu}	Min. re-engagement difference between lower response pressure and normal operating pressure
p _d	Outlet pressure	RSD	Throttle valve		
p _{df}	SRV closing pressure	SSV	Safety shut-off valve		
p _{do}	SRV opening pressure	SRV	Safety relief valve		
p _{ds}	Setpoint of the response pressure	SG	Closing pressure group	ρ _n	Gas density
p _{ds o}	Upper SSV response pressure	t _{Gas}	Gas inlet temperature		
p _{ds u}	Lower SSV response pressure	VS	Valve seat		
p _{f,max}	Maximum closing pressure	w _d	Outlet gas velocity		
		w _u	Inlet gas velocity		
		W _{dso}	Upper adjustment range (SSV)		
		W _{dsu}	Lower adjustment range		

Application, Characteristics, Technical Data

Application

Gas pressure regulator (GDR), direct-acting (operating without auxiliary power), for systems acc. to DVGW - work sheet G 491 (A) and G 600 (A) (TRGI)

Particularly suitable for dynamic regulation sections (e.g. gas fireplaces, natural gas distribution plants, burner, gas engines)

Can be used as an equipment component for gas consumption systems according to Regulation (EU) 2016/426.

Can be used for the gases defined in DVGW - work sheet G 260 / G 262 and neutral non-aggressive gases. (other gases on request)

Features

- Integral pressure-tight model (IS)
- Gas pressure regulator with integrated SSV
- Easy maintenance through replaceable SSV functional units (modular design)
- SSV functional class, optionally A ($W_{dsu} + W_{dso}$) or B (W_{dso})
- outdoor version as standard

Type of model (options)

- Oxygen model ($p_u \leq 10$ bar)
- Without SSV
- With noise reduction
- With SSV manual release
- With SSV - electromagnetic remote release when power is applied or in case of power failure
- With electric position indicator SSV 'Closed' via inductive initiator or via Reed contact
- Control unit optional with safety diaphragm
- With BV breather valve
- With throttle valve (RSD) for impulse line of the regulator
- Coating with epoxy resin in RAL colours

Accuracy class AC / Closing pressure group SG Outlet pressure range p_d	Control units						
	205	275	275-2	320	385	390	485
18 mbar to 100 mbar				10 / 20	10 / 20	10 / 20	5 / 10
90 mbar to 500 mbar		5 / 10					
100 mbar to 500 mbar				5 / 10	5 / 10	5 / 10	5 / 10
350 mbar to 500 mbar			10 / 20				
500 mbar to 1000 mbar	10 / 20						
> 500 mbar		2.5 / 10	5 / 10	2.5 / 10	2.5 / 10	2.5 / 10	
> 1000 mbar	5 / 10						

Safety shut-off valve

Upper response pressure group AG_o in command area w_{dso}	AG_o
50 mbar to 100 mbar	10
> 100 mbar to 500 mbar	5
> 500 mbar	2.5

Lower response pressure AG_u in command area w_{dsu}	AG_u
10 mbar to 30 mbar	20
> 30 mbar to 50 mbar	10
> 50 mbar	5

Technical Data

Type	RS 254 / RS 255
Model	Integral pressure-tight (IS)
Max. allowable pressure PS	16 bar
Nominal size	RS 254: DN 25, DN 50, DN 80, DN 100, DN 150, DN 200 RS 255: DN 50, DN 80, DN 100
Connection type	DIN EN 1092 - PN 16 flanges / ASME - B16.5 flanges Class 150 RF
Material	
Housing / actuator housing/ Control device housing	Al cast alloy
Temperature range, Class 2 (operating/ambient temperature)	-20°C to +60°C
Closing pressure group	SZ 2.5
Function, Strength and Tightness CE mark to PED/ PIN number	DIN EN 334 and DIN EN 14382 CE-0085-AQ0882 / CE-0085-AQ0883
Ex protection	When used adequately, this mechanical equipment has no in herent potential ignition source and thus it is not marked in accordance with the ATEX-Directive. An internal ignition risk analysis was carried out att. DIN EN 1127-1, DIN EN ISO 80079-36 etc..

Mounting position



Only after Consultation with Medenus GmbH

CE EAC

Application, Characteristics, Technical Data

Design and function

The spring-loaded gas pressure regulators RS 254 / RS 255 have the function of keeping the outlet pressure of a gaseous medium constant within allowable limit values, independently of the effect of interferences, such as changes in the inlet pressure and/or in the gas train, in the connected regulation section on the outlet side. The gas pressure regulator is composed of the actuator housing and the 'control unit plus actuator' and 'SSV control device/switching device plus actuator' functional units.

The actuator for the control unit can be produced in various valve seat diameters to suit different nominal sizes. The valve seat models are pre-pressure-compensated and can, if required, be equipped with noise reduction.

The gas flows through the actuator housing in the direction of the arrow. The external measurement line port is used to pass the outlet pressure to be regulated to the bottom of the main diaphragm of the control unit. It compares the actual value with the command variable preset by the force of the setpoint spring. The setpoint required in each case is set via the setting screw. Any deviation from the setpoint is transmitted by the screw spindle to the actuator, which is adjusted such that the actual value is adjusted to the setpoint. In case of zero tap, the actuator will close tight, causing the closing pressure to be established. Optionally, the control unit can be equipped with a leakage gas SRV or a safety diaphragm. In the model with safety diaphragm, the safety diaphragm is located above the main diaphragm. When the main diaphragm ruptures, the safety diaphragm makes contact with the top cover of the control unit and prevents any inadmissible escape of gas into the surrounding atmosphere. In case of inadmissible overpressure or lack of gas in the regulating section, the actuator of the safety shut-off valve arranged in the same housing on the inlet side will shut off the gas flow. To this end, the outlet pressure to be monitored is passed on to the SSV control device via a separate measurement line. As a function of the change in pressure, the SSV diaphragm in the controller is raised or lowered. When the outlet pressure in the regulating section exceeds or falls below a certain response pressure, the switch socket connected to the SSV diaphragm will move to the corresponding disengaging position, the balls of the engaging mechanism will release the SSV screw spindle, and the closing spring will press the SSV valve plate against the valve seat. The SSV actuator shuts off the gas flow gas-tight. The SSV can only be opened by hand and engaged in the open position. To do so, the outlet pressure at the measuring point must be lowered below the upper response pressure or raised above the lower response pressure by at least the re-engaging differential amount (Δp).

The SSV can, except where otherwise stipulated in specific national legislation, be used in either functional class A (with diaphragm rupture protection) and B (without diaphragm rupture protection).

There is also the option of using a remote indication for the SSV position 'CLOSED' and a manual and remote release when power is applied or in case of power failure.

Installation example

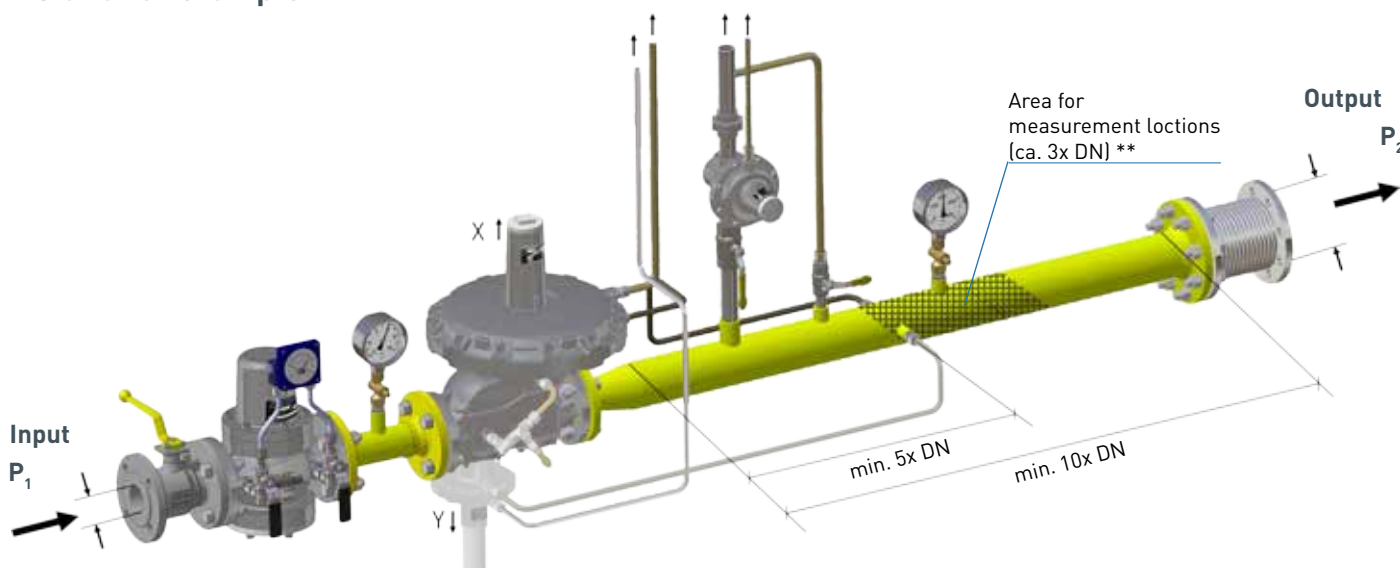

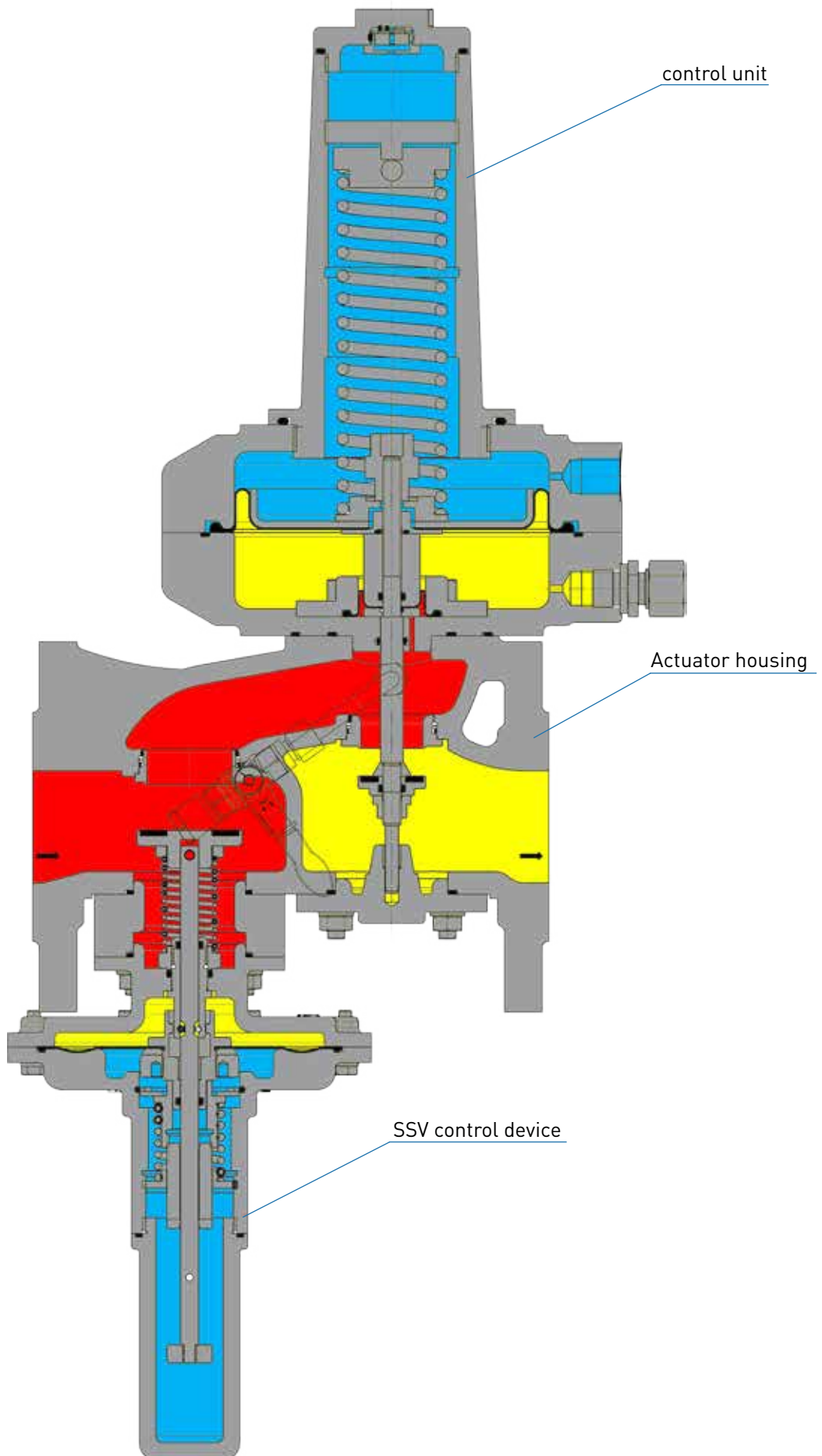

Selection

Note All calculation pressures are absolute pressures. ($p + 1$ bar)

p_u Inlet pressure (bar)
 p_d Outlet pressure (bar)
 Q_n Standard volume flow m^3/h

Calculation of the required K_G value

$p_d / p_u > 0.5$
 K_G value at
 a sub-critical pressure ratio
 $K_G = Q_n / \sqrt{p_d \cdot (p_u - p_d)}$

$p_d / p_u \leq 0.5$
 K_G value at
 a super-critical pressure ratio
 $K_G = 2 \cdot Q_n / p_u$

Note For spring-loaded devices, a capacity reserve of 10-20% is recommended in order to comply with the accuracies given.
 The device is selected on the basis of its K_G value from the table of flow rate coefficients (page 10)

Device selection

Note Closing pressure group: SZ 2,5

For the small load Q_{min} with SZ this yields 2.5: $Q_{min} = 0.025 \cdot K_G \cdot p_{u\ max}$

Small load Q_{min} - When burner is started or at Q_{min} a K_G utilization level of at least 1% should be reached.

Selection of the control unit from the control unit setpoint spring table (page 11)

Selection of the closing pressure group from the closing pressure group table (page 5)

$$p_{f\ max} = p_{ds} \cdot (1 + SG/100)$$

Selection of the SSVs from the SSV control device table (page 12)

Recommended upper SSV response pressure $p_{dso} < 500\ mbar + p_{ds}$

Determination of the upper response pressure

output pressure P_d (mbar)	upper response pressure W_{dso} *
≤ 200	$P_d + 100\ mbar$
$> 200 - \leq 800$	$P_d \times 1,5$
$> 800 - \leq 1600$	$P_d \times 1,3$
> 1600	$P_d + 500\ mbar$

Checking the gas velocities

$$w = 380 \cdot Q_n / (DN^2 \cdot p_{abs})$$

Note The factor 380 refers to an operating gas temperature from approx. 15°C to 20°C. For other temperatures, the velocity must be corrected as follows:
 $w_{corr} = w \cdot (t_{gas} + 273.15) / 290$

Recommended max. gas velocity at the inlet flange:

50 - 70 m/s Lower value for redirections upstream of the control valve, 20 m/s for upstream filters

Recommended max. gas velocity at the outlet flange:

100 - 200 m/s Lower value to reduce noise emissions

Recommended max. gas velocity on impulse tap: 15 - 25 m/s Lower value for outlet pressures below 100 mbar.

The device selected in the example of nominal size DN 80 can be operated under these conditions.

*) The upper response pressure is rounded up to the nearest 10 (for example 251mbar -> 260mbar)

Example:

$p_{u\ min}$ 13,0 bar
 $p_{d\ min}$ 0,25 bar
 $Q_{n\ min}$ 3000 m^3/h

$$1,25\ bar / 14\ bar = 0,089 < 0,5$$

→ Supercritical pressure ratio

$$K_G = 2 \cdot 3000 / 14 = 429\ [m^3/(h \cdot bar)]$$

Ausgewähltes Gerät

Type RS 254
 DN - nominal width 080
 D - valve V 27,5
 KG- value 550 $m^3/(h \cdot bar)$

$$Q_{min} = 0,025 \cdot 550 \cdot 14 = 193\ m^3/h$$

Selected control unit

RE - control unit 275
 Setpoint spring FA11
 (W_{ds} 208 - 339)

AC 5/SG 10 (for RE 275 D - valve 27,5)

Selected SSV

MD-R with FD 913 (285 - 460mbar) AG_o 10
 set to $P_{dso} = 375\ mbar$
 and FE? (? - ? mbar) AG_u 5

Inlet and outlet nominal size of the pipeline according to the selected device: 80 mm
 Selected widening of outlet pipeline: 200 mm

$$w_u = 380 \cdot 3000 / (80^2 \cdot 14) = 13\ m/s$$

$$w_d = 380 \cdot 3000 / (80^2 \cdot 1,25) = 143\ m/s$$

$$w_{Impuls} = 380 \cdot 3000 / (200^2 \cdot 1,25) = 23\ m/s$$

Order data

(Only one option is available in each selection group)

Example:

Gas pressure regulator: RS254/080/275/27,5/MD-R/HDS/links/SR/SM/RSD/BV/N/H/WAZ/So

Order selection	Designation	Order code:	RS254	080	-	275	27,5	MD-R	-	HDS	links	SR	SM	RSD	BV	N	H	WAZ	So
Type																			
RS 254	RS254	RS 254																	
RS 255	RS255																		
DN - Nominal size	Table p.10			080															
Flange model																			
PN 16	-			-															
Class 150	C																		
RE - control unit	Table p.10					275													
D - Orifice (valve seat diameter)							27,5												
SSV																			
with MD control device	MD																		
with MD-R control device	MD-R							MD-R											
SSV functional class																			
A	-								-										
B	B																		
High-pressure screw spindle	fig. p.15																		
without	-																		
with high-pressure screw spindle	HDS									HDS									
Direction of flow																			
Right (from left to right)	-																		
Left (from right to left)	links										links								
Noise reduction	fig. p.14																		
without	-																		
with noise reduction	SR											SR							
Additional unit, control unit	fig. p.14																		
without	-																		
Safety diaphragm	SM												SM						
Throttle valve	BV																		
without	fig. p.14																		
with throttle valve	-																		
mit Drosselventil	RSD													RSD					
SSV valve accessories	fig. p.15																		
without	-																		
Breather valve	BV																		
Electrical position indicator, SSV 'Closed'	fig. p.15																		
without	-																		
with ... , via proximity switch	N																N		
with ... , via Reed contact	R																		
SSV release	fig. p.14																		
without	-																		
with manual release	H																	H	
with electromagnetic remote release, when power is supplied	SG																		
with remote release, in case of power failure	SA																		
Acceptance test certificate to EN 10204/3.1																			
without	-																		
with acceptance test certificate	WAZ																		WAZ
Special model	So																		
- Coating with epoxy resin in RAL colors																			
- Oxygen version																			
- Hydrogen version (Helium leak test)																			

K_G* value and control units

(Valve - flow coefficient for natural gas: $d = 0.64$ ($\rho_n = 0.83 \text{ kg / m}^3$), $t_u = 15 \text{ }^\circ\text{C}$)

Nominal size	RS 254						RS 255		
	DN 25	DN 50	DN 80	DN 100	DN 150	DN 200	DN 50	DN 80	DN 100
control unit Ø	205	205	205	205	275-2	275-2	205	275-2	275-2
Valve seat Ø	320 / 330	320 / 330	275	275	385	385	275	385	385
			390	390	485	485	390	485	485
17.5 mm	200	220							
27.5 mm	420	500	550	600			550		
32.5 mm		750	850	900			750		
42.5 mm			1,450	1,500	1,600		1,250	1,500	1,500
52.5 mm				1,800	2,000		1,700	1,800	1,850
65.0 mm					3,500			2,600	3,200
85.0 mm					4,600			3,500	4,300
95.0 mm					5,800	6,100			4,800
115.0 mm						8,950			
Connection type	DIN EN 1092 - PN16								
	ASME B 16.5 - Class 150								

RE - Regeleinrichtung

Regulator type	Nominal size	Description	Outlet pressure ranges [mbar]	Recommended use of the high-pressure screw spindle in the pressure range [mbar] (Fig. on p.15)
RS254	DN 25	with RE 320 / 330	18 - 200	200 - 800
		with RE 205	200 - 750	750 - 3.000
	DN 50	with RE 320 / 330	18 - 200	200 - 800
		with RE 205	200 - 750	750 - 3.000
	DN 80	with RE 390	18 - 130	130 - 450
		with RE 275	130 - 400	400 - 1.100
		with RE 205	400 - 750	750 - 3.000
	DN 100	with RE 390	18 - 130	130 - 450
		with RE 275	130 - 400	400 - 1.100
		with RE 205	400 - 750	750 - 3.000
	DN 150	with RE 485	18 - 150	150 - 450
		with RE 385	150 - 350	350 - 850
with RE 275-2		350 - 850	850 - 3.000	
DN 200	with RE 485	18 - 150	150 - 450	
	with RE 385	150 - 350	350 - 850	
	with RE 275-2	350 - 850	850 - 3.000	
RS255	DN 50	with RE 390	18 - 130	130 - 450
		with RE 275	130 - 400	400 - 1.100
		with RE 205	400 - 750	750 - 3.000
	DN 80	with RE 385	18 - 350	350 - 850
		with RE 275-2	350 - 850	850 - 3.000
	DN 100	with RE 485	18 - 150	150 - 450
with RE 385		150 - 350	350 - 850	
with RE 275-2		350 - 850	850 - 3.000	

Control unit setpoint spring table

Spring data		Specific command range W_{ds} [mbar]			
Spring no.	Colour [RAL]	RE 205	RE 275	RE 320 / 330	RE 390
FA 01	blank	36 - 39	23 - 25	10 - 12	8 - 10
FA 02	9006	38 - 45	24 - 28	11 - 13	9 - 12
FA 03	5015	44 - 52	27 - 31	14 - 18	11 - 13
FA 04	4002	51 - 64	30 - 37	17 - 22	12 - 15
FA 05	7037	62 - 81	35 - 46	21 - 29	14 - 19
FA 06	9005	78 - 107	43 - 59	28 - 39	18 - 24
FA 07	3020	103 - 147	55 - 80	38 - 54	23 - 32
FA 08	9010	140 - 205	73 - 110	53 - 77	31 - 45
FA 09	7016	195 - 295	100 - 156	76 - 111	42 - 64
FA 10	6010	280 - 430	141 - 225	110 - 166	59 - 94
FA 11	2002	419 - 653	208 - 339	165 - 250	88 - 142
FA 12*	7035	595 - 935	293 - 484	239 - 361	124 - 203
FA 13*	5010	819 - 1408	436 - 726	360 - 544	185 - 305
FA 14*	1028	1245 - 1976	607 - 1017	506 - 765	258 - 428
FA 15*	6018	1212 - 2553	699 - 1333	535 - 978	297 - 568
FA 16*	3020	1330 - 3012	785 - 1580	602 - 1157	333 - 673

* High-pressure spindle HDS required (illustration p.15)

Spring data		Specific command range W_{ds} [mbar]		
Spring no.	Colour [RAL]	RE 275-2	RE 385-2	RE 485
FB 701	6018	59 - 69	31 - 35	19 - 22
FB 702	9006	68 - 83	34 - 41	21 - 25
FB 703	5015	80 - 105	40 - 51	24 - 31
FB 704	4002	96 - 127	50 - 61	28 - 36
FB 705	7037	112 - 156	60 - 77	33 - 44
FB 706	9005	146 - 207	76 - 100	41 - 56
FB 707	3020	184 - 266	98 - 127	51 - 71
FB 708	9010	238 - 358	125 - 167	65 - 94
FB 709	7016	302 - 450	165 - 215	82 - 118
FB 710	6010	397 - 596	212 - 285	105 - 155
FB 711	2002	542 - 814	280 - 390	140 - 209
FB 712	7035	742 - 1078	385 - 520	188 - 275
FB 713*	5010	977 - 1442	515 - 671	246 - 369
FB 714*	1028	1245 - 1878	661 - 873	311 - 479
FB 715*	6018	1547 - 2469	712 - 1186	393 - 618
FB 716*	3020	2136 - 3008	975 - 1514	517 - 752

* High-pressure spindle HDS required (illustration p.15)

Table setpoint spring SAV - control unit

		MD small ball lock up to $W_{ds.o}$ 300mbar				MD-R small ball lock up to $W_{ds.o}$ 3500mbar				HD small ball lock up to $W_{ds.o}$ 14000mbar			
		RS 254: DN 25 - 100 / RS 255: DN 50 - 80											
Spring data		lower response pressure		upper response pressure		lower response pressure		upper response pressure		lower response pressure		upper response pressure	
Feder Nr.	Colour	$W_{ds.u}$ [mbar]	Δp_{wu} [mbar]	w_{dso} [mbar]	Δp_{wo} [mbar]	$W_{ds.u}$ [mbar]	Δp_{wu} [mbar]	w_{dso} [mbar]	Δp_{wo} [mbar]	$W_{ds.u}$ [mbar]	Δp_{wu} [mbar]	w_{dso} [mbar]	Δp_{wo} [mbar]
FE 900	1028					0 - 10	50			0 - 38	500		
FE 901 VA	2002					6 - 30*	50			20 - 120*	500		
FE 902 VA	6010	0 - 12*	20			24 - 74	50			120 - 310*	500		
FE 903	5015	4 - 14	20			36 - 78	50			160 - 316	500		
FE 904 VA	9005	8 - 18	20			58 - 110	50			200 - 400	500		
FE 905 VA	9010	18 - 42	20			110 - 160	50			416 - 650	500		
FE 906	4002	48 - 70	20			162 - 250	50			560 - 940	500		
FD 910	1028			35 - 45	20			100 - 135	50			0 - 38	300
FD 911	2002			45 - 80	20			130 - 250	50			20 - 120	300
FD 912	6010			70 - 120	20			220 - 360	50			120 - 310	300
FD 913	5015			100 - 170	20			320 - 510	50			160 - 316	300
FD 914	9005			140 - 230	20			440 - 700	50			200 - 400	300
FD 915	9010			210 - 370	20			630 - 1130	50			416 - 650	300
FD 916	3020			330 - 570	20			1060 - 1750	50			560 - 940	300
FD 917	5010			460 - 830	20			1420 - 2520	50			4700 - 7300	300
FD 918	9006			650 - 1080	20			1850 - 3200	50			7300 - 12100	300
FD 919	4002			980 - 1500	20			2800 - 4600	50			11700 - 14000	300

		MD big ball lock up to $W_{ds.o}$ 300mbar				MD-R big ball lock up to $W_{ds.o}$ 3500mbar				HD big ball lock up to $W_{ds.o}$ 14000mbar			
		RS 254: DN 150 - 200 / RS 255: DN 100											
Spring data		lower response pressure		upper response pressure		lower response pressure		upper response pressure		lower response pressure		upper response pressure	
Feder Nr.	Colour [RAL]	$W_{ds.u}$ [mbar]	Δp_{wu} [mbar]	w_{dso} [mbar]	Δp_{wo} [mbar]	$W_{ds.u}$ [mbar]	Δp_{wu} [mbar]	w_{dso} [mbar]	Δp_{wo} [mbar]	$W_{ds.u}$ [mbar]	Δp_{wu} [mbar]	w_{dso} [mbar]	Δp_{wo} [mbar]
FM 400	1028	10 - 40*	20			10 - 180*	50			0 - 250	500		
FM 402	6010	35 - 115	20			155 - 380	50			150 - 1000*	500		
FM 404	9005	60 - 245	20			200 - 950	50			650 - 2050	500		
FL 412	6010			40 - 180	20			145 - 670	50			380 - 1400	300
FL 413	5015			70 - 340	20			270 - 1230	50			800 - 2800	300
FL 415	9010							1200 - 4500	50			3200 - 5500	300
FL 417	4010											4500 - 14000	300

*) Standard springs

Dimensions, Connection and Weight

Dimensional drawing

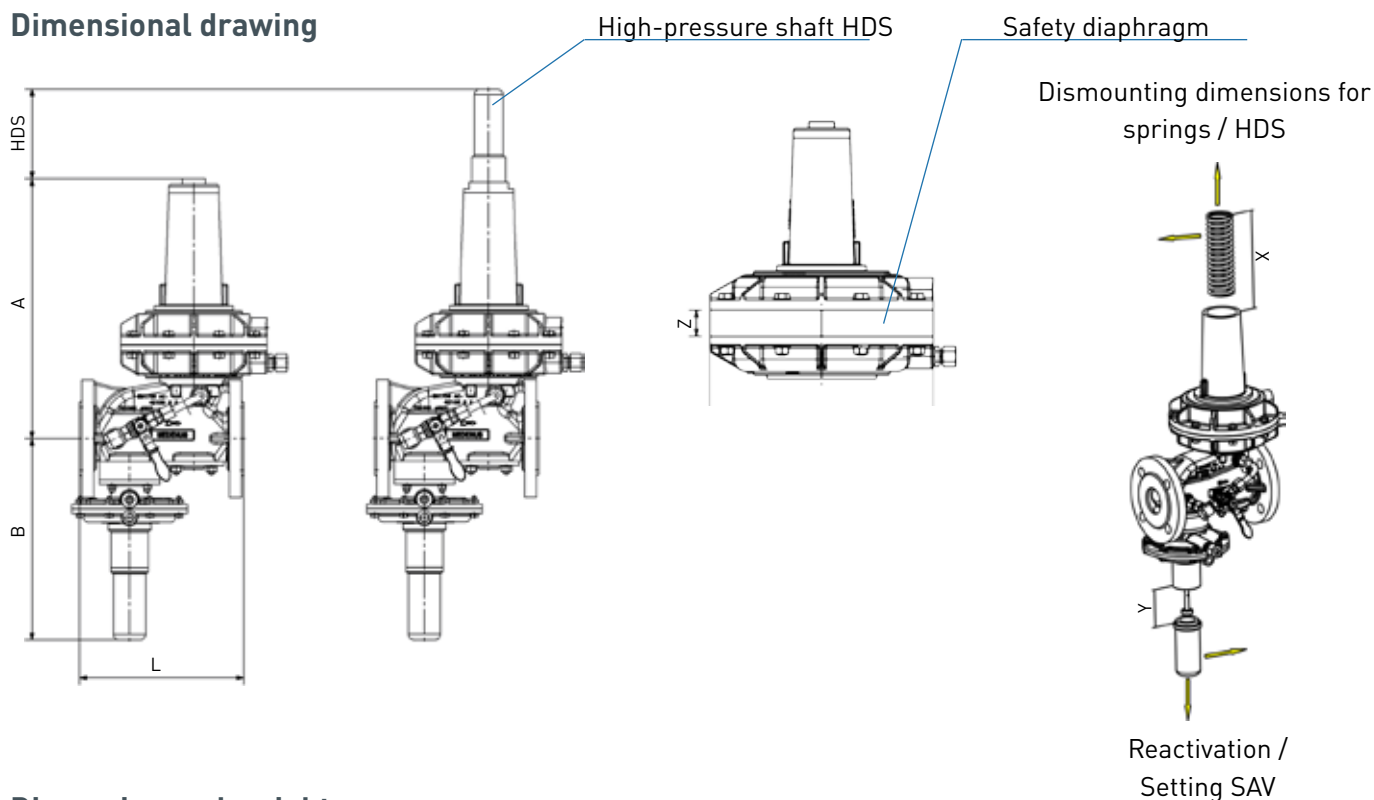

Dimension and weight

		RS 254						RS 255			
		RE	DN 25	DN 50	DN 80	DN 100	DN 150	DN 200	DN 50	DN 80	DN 100
Dimensions	A [mm]	205	346	364	406	421	-	-	406	-	-
		275	-	-	406	421	730	799	406	658	730
		320/330	328	346	-	-	-	-	-	-	-
		385/390	-	-	406	421	716	785	406	644	716
		485	-	-	-	-	722	791	-	644	722
	HDS [mm]		125	125	125	125	205	205	125	205	205
	B [mm]		270	282	305	315	386	400	305	311	386
	L* [mm]		230	230	310	350	480	600	310	410	480
	X [mm]		260	260	260	260	410	410	260	410	410
	Y [mm]		100	100	100	100	150	150	100	150	150
	Safety diaphragm - SM										
	Z [mm]		32,5	32,5	32,5	32,5	32,5	32,5	32,5	32,5	32,5
	Weight										
Weight [kg]		205	11,5	13	22	23	-	-	16	-	-
		275	-	-	24	25	52	82	19	37	52
		320/330	13,5	15	-	-	-	-	22	-	-
		385/390	-	-	28	29	58	88	-	42	58
		485	-	-	-	-	68	98	-	-	68
	HDS - Weight [kg]		0,6	0,6	0,6	0,6	1,6	1,6	0,6	1,6	1,6
Safety diaphragm - SM - Weight [kg]		205	2	2	2	2	-	-	2	-	-
		275	-	-	3	3	3,3	3,3	3	3,3	3,3
		320/330	3	3	-	-	-	-	-	-	-
		385/390	-	-	5	5	6	6	5	6	6

Example: RS254/050/320 with HDS and safety diaphragm

Weight (regulator + HDS + SM): 15 kg + 0.6 kg + 3 kg = 18.6 kg

Dimensions [A + HDS + SM]: 346 mm + 125 mm + 32.5 mm = 503.5 mm

Equipment / Options

Safety diaphragm

In the version with safety diaphragm, the safety diaphragm is located above the main diaphragm, which rests against the upper hood of the control device when the main diaphragm ruptures and prevents inadmissible gas leakage into the surrounding atmosphere.



Noise reduction

The sound reduction made of metal foam reduces the noise due to flow velocity in the gas pressure regulator by up to -15 dB (± 3 dB)



Throttle valve RSD

The RSD is a throttle valve, which controls the volume flow in the measuring line by means of a continuously variable Cross-sectional constriction influenced from the outside. Adjustment by means of a hexagon key (4mm)

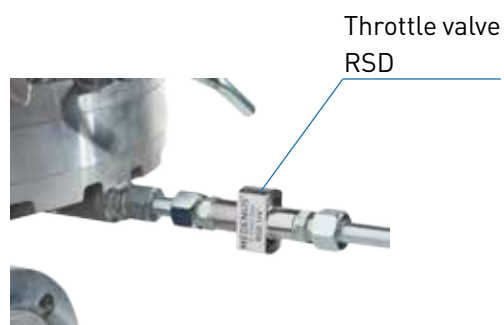

SAV remote release

The direct-acting solenoid valve serves as a remote electromagnetic release to close the safety shut-off valve during current or power failure.



Breathing valve BV

The breathing valve BV serves to protect the installation space against impermissible gas leakage from the comparator membrane spaces of safety shut-off valves.

It also serves as a replacement for the costly and time-consuming laying of respiratory conduits.



Breathing valve BV

Signal transmitter / Inductive transmitter

Signal and inductive sensors are used to monitor the position (closed or open position) of the Safety shut-off valve by means of remote display.



Signaler sensor

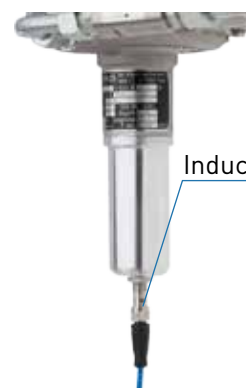

Inductive sensors

High-pressure shaft HDS

The high pressure shaft (HDS) is used for adjustment of the control spring at high pressure. (See spring tables p.11)



Contact

If you want to know more about our products and services, please contact your local representative or visit our website at www.medenus.de/en.



MEDENUS
Gas-Druckregeltechnik
GmbH

Im Langen Feld 3



THE MEDENUS PLUS

10 reasons for good business relations

1. Consultancy expertise and quality standards developed over decades
2. Broad and proven standard range of feedback controllers
3. Modern, fast and efficient production for series products and for individual orders
4. Customized design of pressure regulators and vacuum regulators and special designs
5. Guaranteed deadline compliance with a delivery time guarantee
6. Fast response time in all matters
7. Sufficiently large parts storage for production and spare parts
8. Customized theory & practice training courses
9. Modular design right across the entire product range to facilitate optimized handling of spare parts
10. Made in Germany

In the download area of our homepage, different languages of this document are available. You can use the following QR codes and links to go directly to this document in your language.

