

Pressure transmitter PASCAL Ci4

with threaded connection

Type series CI410.



Application area

- Machinery construction
- Chemical and petrochemical industry
- General process technology

Application

The digital pressure transmitter PASCAL Ci4 is suitable for measuring the relative and absolute pressure of gases, vapors and liquids. Due to the design the transmitter is suitable for highest requirements. The 4 operation buttons allow an easy and fast parameterisation.

Features

- Pressure transmitter for the measuring of relative and absolute pressures of gases, vapors and liquids
- Stainless steel case in sturdy design, degree of protection IP 65/67
- Accuracy $\leq 0.1\%$
- High-resolution graphic display with Intuitive 4-button operation and backlight
- Comprehensive parameterising functions
- Comprehensive simulation and diagnostic functions
- Quick access to device data
- Development according to SIL2
- Nominal range 0.25 bar to 400 bar
- Turndown up to 100:1
- Measuring rate up to 100 Hz
- Output signal 4...20 mA with HART® protocol
- Configuration memory
- Digital communication via PDM/EDD, FDT/DTM, 375/475 Field Communicator
- Output functions: linear, invers, square root, table function with up to 64 support points
- Media temperature $-40...100\text{ }^{\circ}\text{C}$
- Wetted parts stainless steel
- Case design:
 - process connection bottom
 - process connection at back
- Process connections: various screw-in thread with internal diaphragm
- Approved according to NAMUR 95
- EAC declaration (upon request)

Options

- Accuracy $\leq 0.075\%$
- Approvals/Certificates
 - Explosion protection for gases and dust
 - Classification per SIL2
 - Certificate of measuring equipment for Russian Federation
 - Material certificate per EN 10204
 - Calibration certificate per EN 10204
- Operating software LAB4Level for level measurements
- Removable display and control unit
- Degree of protection IP 69K

Technical data

Measuring ranges

Up to a turndown of 100:1 the measuring span can be freely selected.

Nominal range	Measuring span		Overload capacity	Lower measuring range limit **	Sensor type
	min	max			
-0.25...0.25 bar rel.	0.0025 bar	0.5 bar	1 bar rel.	750 mbar abs	Piezoresistive
0...1 bar *	0.01 bar	2 bar	3 bar rel.	100 mbar abs	
0...4 bar rel. *	0.04 bar	5 bar	10 bar rel.	100 mbar abs	
0...16 bar rel. *	0.16 bar	17 bar	60 bar rel.	100 mbar abs	
0...40 bar rel. *	0.4 bar	41 bar	100 bar rel.	100 mbar abs	
-1...1 bar rel.	0.01 bar	2 bar	20 bar rel.	30 mbar abs	
-1...4 bar rel.	0.04 bar	5 bar	50 bar rel.	30 mbar abs	
-1...16 bar rel.	0.16 bar	17 bar	60 bar rel.	30 mbar abs	
-1...40 bar rel.	0.4 bar	41 bar	150 bar rel.	30 mbar abs	
-1...100 bar rel.	1 bar	101 bar	200 bar rel.	0 mbar abs	Thin film
-1...400 bar rel.	4 bar	401 bar	750 bar rel.	0 mbar abs	
0...1 bar abs	0.01 bar abs.	1 bar abs.	3 bar abs.	30 mbar abs	Piezoresistive
0...4 bar abs	0.04 bar abs.	4 bar abs.	10 bar abs.	30 mbar abs	
0...16 bar abs	0.16 bar abs.	16 bar abs.	60 bar abs.	30 mbar abs	

* Short term or sporadic measurement in vacuum range permitted up to lower measuring limit. Lower range value up to -1 bar rel. adjustable.

** Vacuum-proof designs are available upon request.

Constructional design / case

Design: Two-chamber case, continuously rotatable by $\pm 170^\circ$

Case surface blasted

Material case:
 ■ Stainless steel mat.no. 1.4301/1.4305 (304/303)
 ■ Stainless steel mat.no. 1.4404 (316L)

Material front cover:
 ■ Stainless steel mat.no. 1.4305 (303)
 ■ Stainless steel mat.no. 1.4404 (316L)
 ■ Polypropylene, black

Gaskets: Silicone / NBR

Degree of protection per EN 60529:
 IP 65 / IP 67
 Option: IP 69K

Climatic category per EN 60721 3-4: 4K4H

Vibration resistance per EN 61298-3:
 10...60 Hz: ± 0.35 mm
 60...1000 Hz: 5 g

Material window:
 ■ Macrolon
 ■ Non-splintering glass (requires front cover of stainless steel)

Elec. connection:
 ■ Circular connector M12
 ■ Cable gland M16x1.5, PA black
 ■ Cable gland M16x1.5, stainless steel
 ■ Cable gland M20x1.5, PA black
 ■ Cable gland M20x1.5, stainless steel
 ■ 1/2" NPT, PA black

Further connections upon request

Terminal blocks:
 ■ Spring clamp terminals up to 1.5 mm²
 ■ Pole terminals up to 2.5 mm²
 ■ Screw terminals up to 2.5 mm²

Weight: Approx. 1.4 kg

Type plate: Laser marking

Process connection

Position:
 ■ bottom
 ■ back *

* Flush mounting upon request

Design:
 ■ G 1/2 B per DIN EN 837-1
 ■ G 1/4 B per DIN EN 837-1
 ■ G1/4 A per DIN EN ISO 1179-2 (DIN 3852-11) model E
 ■ 1/2 " NPT
 ■ 1/4 " NPT

Further process connections upon request

Material wetted parts

Sensor :	Piezoresistive	Thin film
Sensor diaphragm:	1.4404/1.4435 (316L)	1.4542 (630)
Socket:	1.4404/1.4435 (316L)	1.4301/1.4404 (304/316L)

Measuring system

Sensor:	Piezoresistive	Thin film
Sensor filling:	Synthetic oil, free of silicone FD1, FDA listed	Without

Accuracy

Reference cond. per EN 61298-1:
 $T_U = \text{const. (15...25) } ^\circ\text{C}$
 $\varphi = \text{const. (45...75) \% r.F.}$
 $p_U = \text{const. (860...1060) mbar}$
 $U_B = 24 \text{ V DC } (\pm 3 \text{ V DC})$
 $R_B = 50 \text{ } \Omega$, HART: 250 Ω
 Ground connected
 $MBA = 0 \text{ bar}$

Calibration position: Process connection bottom: vertical
 Process connection back: horizontal

Reference accuracy:

Per EN 60770 incl. non-linearity, hysteresis and repeatability refer to the adjusted measuring span:

Nominal range	Turndown $\leq 5:1$	Turndown $> 5:1$
1 - 400 bar	$\leq \pm 0.1 \%$	$\leq \pm 0.02 \% \times \text{TD}$
0.25 bar	$\leq \pm 0.15 \%$	$\leq \pm 0.03 \% \times \text{TD}$

Nominal range	Turndown $\leq 3,75:1$	Turndown $> 3,75:1$
1 - 40 bar	$\leq \pm 0.075 \%$	$\leq \pm 0.02 \% \times \text{TD}$

Long-term drift: Refer to nominal range
 $\leq 0.1 \%$ /year

Operational availability: $< 12 \text{ s}$

Response time t_{90} at current output:
 for 20 Hz measuring rate: typically 120 ms
 for 100 Hz measuring rate: typically 50 ms

Temperature influence, case:

Refer to nominal range		
Nominal range	temp. $-20...80 \text{ } ^\circ\text{C}$	temp. $-40...-20 \text{ } ^\circ\text{C}$
1 - 400 bar	$\leq \pm 0.1 \%/10\text{K}$, max. 0.3 %	typical $\leq \pm 0.2 \%/10\text{K}$
0.25 bar	$\leq \pm 0.15 \%/10\text{K}$, max. 0.4 %	

Indication

Display:

- High-resolution graphic display with backlight
- 4-button operation
- Freely configurable display modes
- continuously rotatable by ± 170 (detent every 90°)
- Optional: Remote display and control unit, can be used up to 10 m away from measuring point

Configuration memory:

- All parameterisation data can be copied from the device into the configuration memory in the display module. The data is permanently stored there, even in the event of power failure.
- The parameters can be transferred simply and quickly to other devices.

Output

Signal: 2-wire technology 4...20 mA
 Lower limit 3.8...4 mA
 Upper limit 20...21 mA
 Lower alarm current $< 3.6 \text{ mA}$
 Upper alarm current $> 21 \text{ mA}$
 Current limitation 22 mA
 Digital communication: HART ® protocol, version 7

Device driver:

- EDD für SIMATIC PDM
- DTM for PACTware or compatible systems (FDT compliance)
- EDD for 375 / 475 Field Communicator

Function:

- linear
- inverse response
- by square root
- table function with up to 64 support points

Turndown: Max. 100:1

Damping: 0...999.9 s selectable in steps of 0.1 s

Measuring rate: 20 Hz, switchable to 100 Hz

Resolution: 0,5 μA

Current sensing func. 3.55...21.5 mA selectable in steps of 0.001 mA

Load R: $R \leq (U - 12\text{V DC}) / 0.022 \text{ A } [\Omega]$

$U = \text{supply voltage}$

for HART ® communication $R \geq 230 \text{ } \Omega$

Supply voltage

Functional range: 12...30 V DC, protected against polarity reversal

Ripple: $< 5 \%$

Temperature ranges

Ambient: $-40...80 \text{ } ^\circ\text{C}$
 (Display visibility is limited at temperatures below $-30 \text{ } ^\circ\text{C}$)

Media: $-40...100 \text{ } ^\circ\text{C}$

Storage: $-40...80 \text{ } ^\circ\text{C}$

Tests and certificates

Ex approvals

ATEX:	TÜV 13 ATEX 120264 X ⊕ II 1/2G Ex ia IIC TX Ga/Gb ⊕ II 1/2D Ex ia IIIC Txx °C Da/Db ⊕ II 2G Ex ia IIC TX Gb ⊕ II 2D Ex ia IIIC Txx °C Db
IECEX:	IECEX TUN 13.0018X Ex ia IIC TX Ga/Gb Ex ia IIIC Txx °C Da/Db Ex ia IIC TX Gb Ex ia IIIC Txx °C Db

Please note:

For all nominal ranges, except:

-1...1 bar rel. bis -1...40 bar rel.

more detailed information can be found in Ex Safety Instruction XA_010.

For the nominal ranges:

-1...1 bar rel. bis -1...40 bar rel.:

more detailed information can be found in Ex Safety Instruction XA_011.

EMC *:	Per DIN EN 61326-1, NAMUR NE21 * A deviation of accuracy due to EMC influence up to 0.25 % is impossible for a design with process connection at the back.
SIL 2:	Functional safety per EN 61508, classification per SIL2 For detailed information see SIL instruction SA_001
NAMUR:	Approved according to NE95, Test report TP14033 available upon request

- EAC declaration upon request
- Certificate of measuring equipment for Russian Federation

Parameterisation, simulation and adjustment

Parameterisation

Parameter	Values	Default setting
Device		
device ID	16 digits, freely selectable	LABOM PASCAL Ci4
lower range value	at any value within nominal range	0 bar respectively 0 bar abs.
upper range value	at any value within nominal range	end of nominal range
measuring rate	20 Hz, 100 Hz	20 Hz
damping	0.0...999.9 s	0.0 s
Display and control unit		
pressure unit	mbar, bar, Pa, hPa, kPa, MPa, g/cm ² , kg/cm ² , psi, atm, Torr, mmH ₂ O, mH ₂ O, inH ₂ O, ftH ₂ O, mmHg, inHg	bar
temperature unit	°C, °F, °R, K	°C
lighting	on, off	on
language	English, German	German
	English, Chinese	as ordered
	English, Spanish, French	as ordered
	English, Polish, German	as ordered
	English, Turkish, German	as ordered
decimal point	auto, x.xxxx, xx.xxx, xxx.xx, xxxx.x, xxxxx	auto
display mode	five values, four values, three values, two values, big display	four values
main value	pressure, current (%), current (mA)	pressure
secondary values	pressure, current (%), current (mA), sensor temperature, device ID, HART-TAG, HART descriptor, <empty>	current (%), current (mA), device ID
Current output		
output function	linear, inverse response, by square root, table function	linear
table function	% of m.r., output current	depends on device
number of table points	2...64	2 (0 % ≙ 4 mA, 100 % ≙ 20 mA)
lower current limit	3.8...4.0 mA	3.8 mA
upper current limit	20...21 mA	20.5 mA
alarm current	low (<3.6 mA), high (> 21.0 mA)	low (<3.6 mA)
position correction (mounting position)	on, off	off
Maintenance counter		
maintenance interval	0...9999 days	0 days
status	on, off	off
HART data		
HART address	0...63	0
number of response preambels	5...20	5
current mode	proportional, constant	proportional

Diagnostic functions

Self- diagnosis	Description	Value range
RAM-Test	Permanent check of the read/write memory	/
ROM-Test	Permanent check of the checksum via the program memory	/
Bridge circuit test	Permanent check of the bridge circuit	/
CRC parameterisation test	Permanent check of the checksum via the parameter memory	/
Electronics temperature monitoring	Permanent check of the electronics temperature	/
Process diagnostics		
Maintenance timer	Check of the maintenance cycles	/
Operating hours counter	Capture of operating hours	/
Min/Max values	For process pressure and sensor temperature	/
Measuring circuit diagnostics		
loop-test	Setting of a fixed current value at the output	3.55...21.5 mA
pressure simulation	Setting a fixed pressure value, it also considers damping and tabular function unlike the current simulation	Nominal range

Adjustment

Type	Description
zero point correction	adjusts reading to zero at ambient pressure (for differential and gauge pressure devices)
position correction	adjusts reading of mounted device to zero at ambient pressure
lower adjustment	adjusts reading to applied pressure (affects zero point + span)
upper adjustment	adjusts reading to applied pressure (affects span only)
current adjustment	adjusts current output to achieve 4 resp. 20 mA at the end of the measurement chain

Alternative and additional possibilities of parameterisation for devices with level software LAB4Level

Parameter	Values	Default setting
Display and control unit		
filling height unit	mm, cm, m, ft, in, yd	m
volume unit	l, hl, m ³ , in ³ , ft ³ , gal	l
weight unit (mass)	g, kg, t, lb	kg
density unit	g/cm ³ , kg/cm ³ , t/m ³ , kg/l, lb/in ³ , lb/ft ³	g/cm ³
display mode	level 4 values, level 2 values, five values, four values, three values, two values, big display	level 4 values
main value	filling height, volume, weight, pressure, current in %, current in mA	filling height
secondary values	filling height, volumen, weight, pressure, static pressure, current in %, current in mA, sensor temperature, density, device ID, HART-TAG, HART-Descriptor, <leer>	current in %, current in mA, device ID
Level		
density	0.1...20 g/cm ³	1 g/cm ³
offset height	max 99.999 m	0 m
tank shape table	on/off	off (= linear)
table function	64 support points (filling heights/volume)	
Current output		
measured value	height, volume, weight, pressure (equal 4...20 mA)	height
number of table points	0 / 2...64	0

Diagnostic functions

Measuring circuit diagnostics		
simulation function	pressure, filling height, volume, weight (mass), current	/
min/max values	for process pressure, sensor temperature, filling height, volume and weight	/

Connection diagram

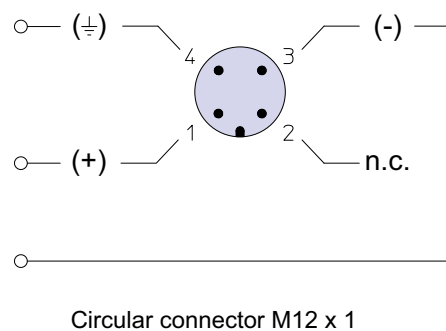
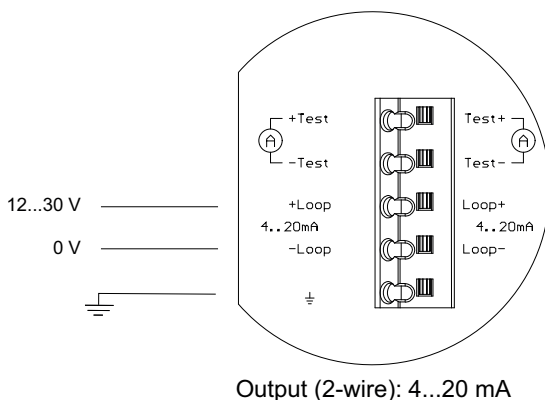

Dimensions

Case

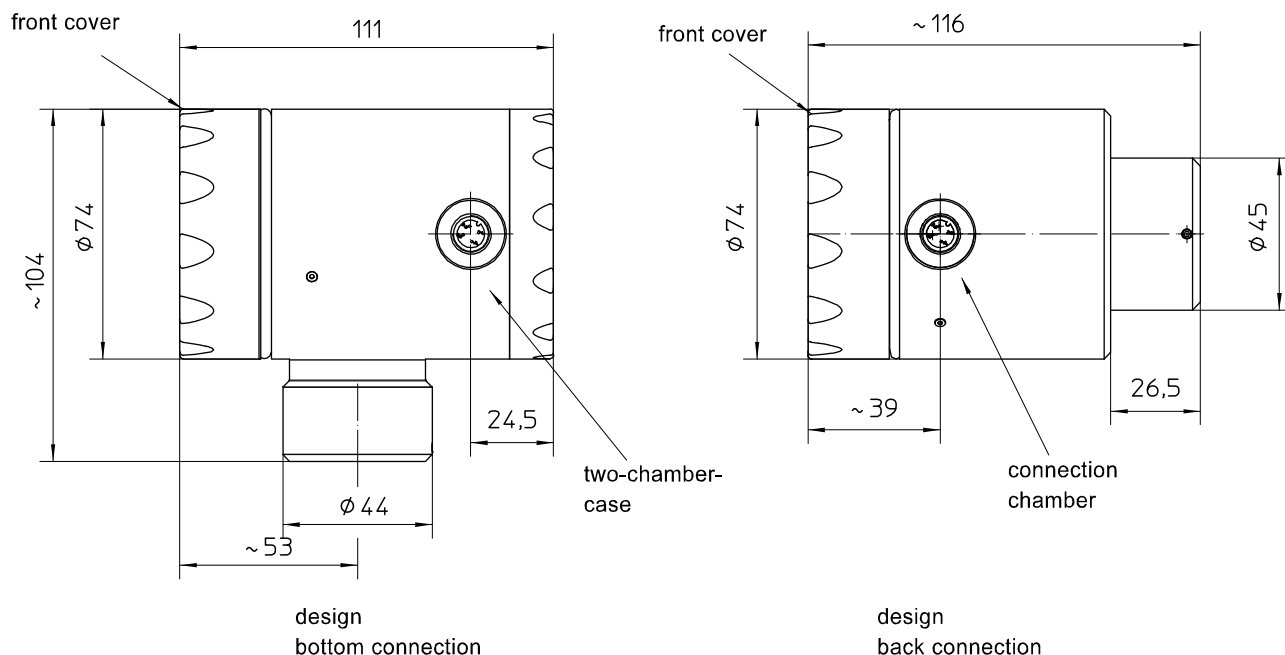

Electrical connections

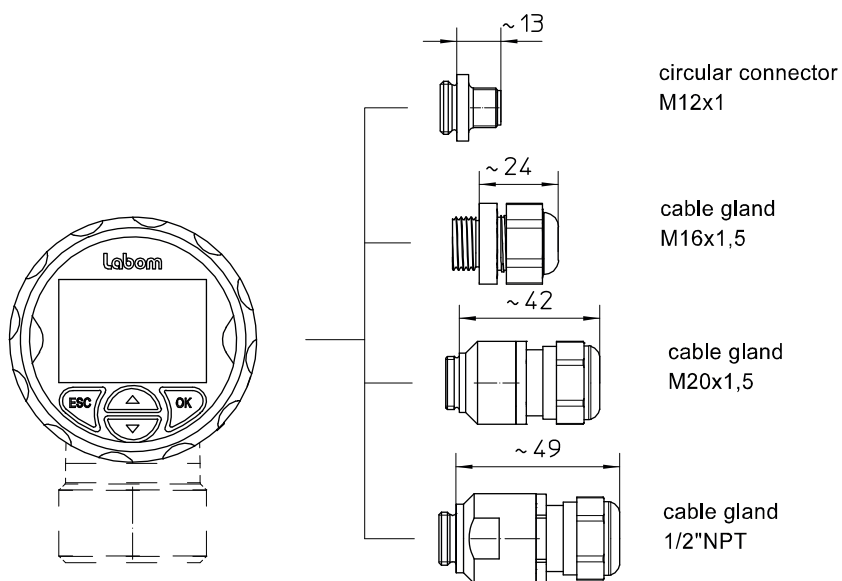

All dimensions are in millimeters

Process connections

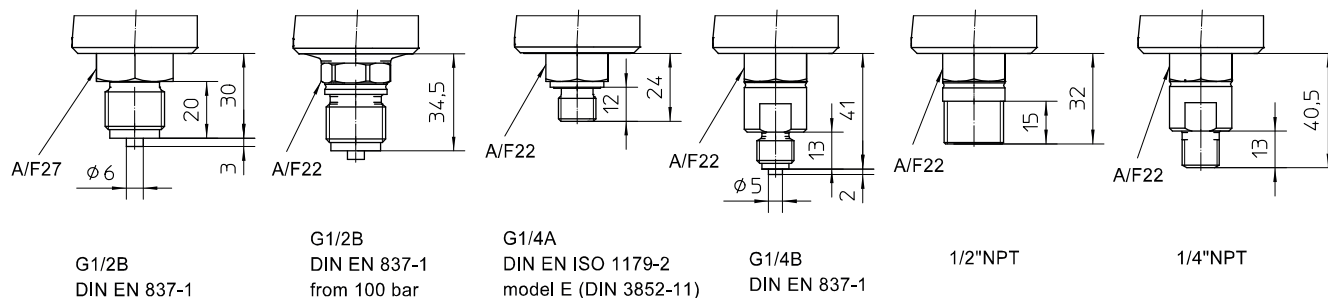

All dimensions are in millimeters

Remote display and control unit (Type series MC1140)

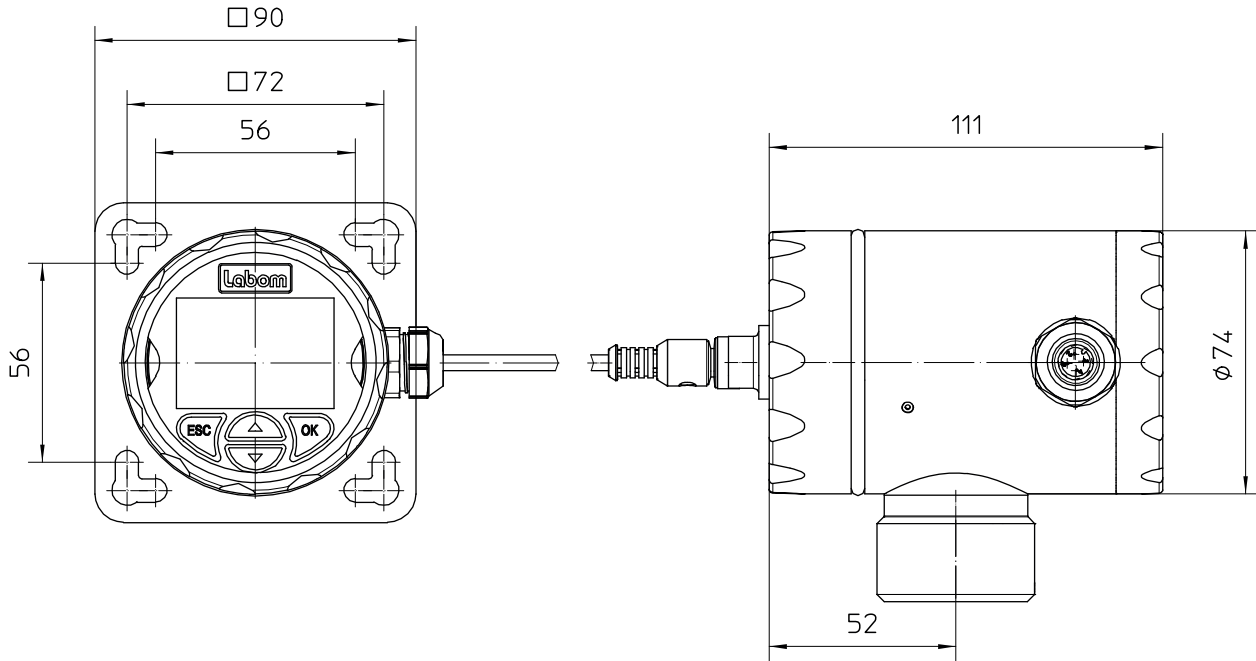

All dimensions are in mm

Order details

Pressure transmitter PASCAL Ci4 with threaded connection Type series CI4100

Order details pressure transmitter PASCAL CI410. with threaded connection					
CI4100	process connection bottom				
CI4103	process connection back				
	nominal range	turndown	overload limit [bar]	sensor type	
A1078	-0.25...0.25 bar rel.	TD up to 100:1	1	piezoresistive	
A1053	0...1 bar rel.		3		
A1056	0...4 bar rel.		10		
A1059	0...16 bar rel.		60		
A1061	0...40 bar rel.		100		
A1053.1	-1...1 bar rel.		20		
A1056.1	-1...4 bar rel.		50		
A1059.1	-1...16 bar rel.		60		
A1061.1	-1...40 bar rel.		150		
A3063	-1...100 bar rel.		200		thin film
A3066	-1...400 bar rel.		750		
B1053	0...1 bar abs.		3	piezoresistive	
B1056	0...4 bar abs.		10		
B1059	0...16 bar abs.		60		
F1	parameterisation		factory settings (standard)		
F2		as per customer's specification (pls. specify)			
H21	output signal	4...20 mA, with HART protocol			
Y1.	material case	stainless steel mat.-no. 1.4301 (304)			
Y2.		stainless steel mat.-no. 1.4404 (316)			
1	material front cover	polypropylene (black), window Macrolon			
2		stainless steel, window non splintering glass			
3		stainless steel, closed, without window			
			default language	available language	
M21.1	display	High-resolution graphic display with backlight, intuitive 4-button operation, quick access to device data	German (standard)	English, German	
M22.1			English		
M22.2			Chinese	English, Chinese	
M23.1			English		
M23.2			Spanish	English, Spanish, French	
M23.3			French		
M25.1			English	English, Polish, German	
M25.2			Polish		
M25.3			German		
M26.1			English	English, Turkish, German	
M26.2			Turkish		
M26.3			German		
M1			without display		
T20.	electrical connection	cable gland	M16 x 1.5 polyamide, for cable Ø 4.5-10 mm		
T22.			M16 x 1.5 stainless steel, for cable Ø 5-9.5 mm		
T15.			M20 x 1.5 polyamide, for cable Ø 7-13 mm		
T17.			M20 x 1.5 stainless steel, for cable Ø 8-13 mm		
T27.			1/2" NPT polyamide, for cable Ø 6-12 mm		
0		cable clamps	spring clamp terminals up to 1.5 mm ²		
5			pole terminals 2.5 mm ²		
6			screwed terminals 2.5 mm ²		
T30		circular connector M12 x 1 (4 pin)			
K1010		process connection	G1/2 B per DIN EN 837-1		
K1002	G1/4 B per DIN EN 837-1				
K1024	G1/4 A per DIN EN ISO 1179-2 (DIN 3852-11) model E				
K1070	1/2" NPT				
K1072	1/4" NPT				
K9999	as per indication				

Additional features (to be indicated if required)		
Q11	Accuracy	≤ 0.075 ¹
S66	Ex marking ^{2,3}	ATEX
		Ex II 1/2G, II 2G Ex ia IIC TX Ga/Gb, Gb
S76	Ex marking ^{2,3}	ATEX
		Ex II 1/2D, II 2D Ex ia IIIC Txx°C Da/Db, Db
S62	Ex marking ^{2,4}	IECEX
		Ex ia IIC TX Ga/Gb, Gb
S77	Ex marking ^{2,4}	IECEX
		Ex ia IIIC Txx°C Da/Db, Db
T4	degree of protection	IP 69K ²
X4	operating software LAB4Level for level applications	
W1020	material certificate	per DIN EN 10204-3.1, wetted parts
W1201	calibration certificate	per DIN EN 10204-3.1, 5 measuring points
W2602	functional safety per EN 61508, classification per SIL2	
W2673	certificate of measuring equipment for Russian Federation	
Accessories		
MC1140	PASCAL Ci4 remote display and control unit including wall bracket	
	material stainless steel, incl. front ring with seal and blind cap with circular connector M12x1	
A1.	connection cable	length: 10 m, material: PUR, with circular connector M12 x1 (further lengths upon request)
1	Internal cable clamps	spring clamp terminals up to 1.5 mm ²
2		pole terminals 2.5 mm ²
3		screwed terminals 2.5 mm ²
T1	degree of protection	IP 65 / IP 67 (standard)
MZ8120-A11	mounting set for wall bracket	2 mounting brackets for pipe and frame mounting Ø 30-50 mm, incl. nuts and washers
MZ8120-A12		2 mounting brackets for pipe and frame mounting Ø 40-64 mm, incl. nuts and washers

Order code (example): **CI4100 – A1056 – F1 – H21 – Y12 – T200 – K1010**

¹ only for nominal ranges: 1...40 bar and 1...16 bar abs at a Turndown of ≤ 3.75:1

² requires front cover of stainless steel

³ for all nominal ranges except: -1...1 bar rel. up to -1...40 bar rel.

⁴ only for the nominal ranges: -1...1 bar rel. up to -1...40 bar rel.