



USER MANUAL

LIA SERIES

Optical Linear Encoder with Online Compensation

Index

1.	Features and Applications	4
2.	Safety	5
2.1	General Information	5
2.2	Notes on Legal Requirements	6
2.3	Notes on Transport, Storage and Handling	7
2.4	Notes on Operation	8
2.5	Notes on Maintenance	8
3.	Functional Elements	9
3.1	Online Compensation (Offset and Amplitude Control)	9
3.2	Switch Sensor	10
3.3	Switch Foil	11
4.	Technical Data	12
4.1	Resolution and Accuracy (Definition)	12
4.2	Mechanical Data	13
4.3	SINGLEFLEX and DOUBLEFLEX Scale Tape	14
4.4	Guide Tape and Mounting Tool (FAV)	15
4.5	QUICK GUIDE	16
4.6	QUICK GUIDE Mounting Tool	17
4.7	Electrical Data	18
4.8	Switch-On Behaviour	19
4.9	Attainable Traversing Speed	19
4.10	Ambient Conditions	20
4.11	Cable	20
4.12	Connector Variants	21
4.13	PIN Assignment	22
4.14	PIN Assignment for JST Miniature Connector	24
4.15	Electromagnetic Compatibility (EMC)	25
4.16	Shielding Concepts	26
4.17	Voltage Output $1 V_{PP}$	27
4.18	Square-Wave Output RS-422	28
4.19	Switch Sensor TTL	29
4.20	Switch Sensor MOS-Relay LIA 21	30
4.21	Switch Sensor Open Collector	30
4.22	Connection Circuits for JST Miniature Connector	30

5.	General Installation Notes	32
5.1	Delivery Contents	32
5.2	Installation Position	32
5.3	Scale Tape Position	35
5.4	Mounting Surfaces for Scanning Head and Scale Tape	36
5.5	Mounting Steps	37
5.6	Specifying the Switch Point of the Switch Sensor for LIA 21	52
6.	Mounting Drawing - LIA 20 / 21	53
6.1	Scanning Head LIA 20 / 21	53
6.2	Assignment of Scanning Head, Scale Tape and Measuring Length	54
6.3	Using of Switch Sensor and Switch Foil (LIA 21)	54
6.4	Permissible Mounting Tolerances and Position Deviations (Coordinates)	57
7.	Signal Adjustment with ADJUSTMENT TOOL	58
7.1	Functions of the ADJUSTMENT TOOL	58
7.2	Dynamic Offset and Amplitude Control (Online Compensation)	58
7.3	Scope of Delivery	58
7.4	EPIFLEX Software	59
8.	Cleaning	60
8.1	Measuring System	60
8.2	Scale Tape	60
9.	Troubleshooting	61
10.	Ordering Key	63
10.1	Scanning Head	63
10.2	Speed Chart for LIK Series	64
10.2.1	LIK Series with Op-Amp	64
10.2.2	LIK Series without Op-Amp	66
10.3	Scale Tape	68
10.4	ADJUSTMENT TOOL	69

1. Features and Applications

Position encoders in drive systems have to meet high and controversial demands, especially in linear drive systems. The demands opposing each other are high accuracy and resolution on the one hand and low mass, small dimensions and high measuring speed on the other hand.

- The graduated scale is definitive for the quality of a linear encoder. Requirements for maximum position deviations of $\pm 2 \mu\text{m}$ per meter or less are no rarity. The emphasis is mostly on the avoidance of short-range errors, since long-range errors, mostly linear error components, can often be compensated.
- The concentration of multiple axes in motion in very tight spaces, such as in semiconductor-producing machines, requires the miniaturization of the drives, guideways and encoders.
- High machining speeds and therefore high accelerations make low masses of the components in motion essential.

The LIA incremental encoders from NUMERIK JENA are equipped with features which are supposed to fulfill these high requirements in an ideal way.

- Due to an interpolation circuitry which is integrated in a 15-pin D-sub connector or in the scanning head, a resolutions down to 50 nm is possible without any additional electronics.
- The permissible traversing speed for a sinusoidal signal output amounts to 10 m/s. A Square wave signal output with a resolution of 0.1 μm allows a permissible traversing speed of 1.6 m/s.
- The short-range position errors (interpolation errors) were significantly reduced by introducing an electronic compensation of amplitude and offset deviations of the coarse signals. This compensation functions without following error in all velocity ranges.

Additional features:

- Reference signal(s) with repeatability accurate to a specific increment, regardless of the direction from which the reference mark(s) is/are traversed
- Compact size and large mounting tolerances
- High resistance to contamination due to 2-field scanning
- Possibility of electronic signal adjustment (signal optimization after mounting)
- Optional, additional optical switch sensor integrated in the scanning head (LIA 21)
- Special, easy to mount scale tapes (SINGLEFLEX and DOUBLEFLEX) for a variety of applications and ambient conditions

Applications:

- Production and inspection machines for the semiconductor industry
- Linear units, drives and coordinate tables
- Measuring machines and measuring microscopes
- Positioning and measuring devices for medical technology
- Precision devices for reprography
- Precision machining
- Robotics

2. Safety

2.1 General Information

- Make sure to familiarize yourself thoroughly with the contents of these installation instructions before installing and starting up the encoder!
- Please contact the support of NUMERIK JENA GmbH or an authorized representation for further information. Please visit the NUMERIK JENA website to get the contact information.
- NUMERIK JENA GmbH is not liable for damages caused by unauthorized handling of the encoders. Any unauthorized handling leads to forfeiture of all warranty claims.
- The encoders are guaranteed to function if the mounting and operating conditions are maintained as stated in these mounting instructions.
- Make sure to follow the right sequence of the mounting steps during mounting.
- NUMERIK JENA GmbH does not assume any liability for any damages or operating errors caused by incorrect installation or operation.
- The stated tolerances must be maintained in order to achieve the accuracies listed in the specifications!
- If the machine tolerances exceed the tolerances stated in the mounting instructions, errors can occur in both the operation and during measuring. NUMERIK JENA GmbH assumes no liability for this.
- Please refer to the operating manuals and safety instructions included with the devices to ensure the reliable operation of the encoder systems, especially pertaining to:
 - Auxiliary electronic units
 - Counters
 - Displays
 - Controllers
 - Encoders
 - Base mechanical devices (machine tools)
- Please pay attention to the safety instructions and warning symbols!



Danger to the device or to the function of the device!



Pull the plug!



Highly inflammable!

2.2 Notes on Legal Requirements

- The NUMERIK JENA encoders conform to EC standards and carry the CE mark.
- NUMERIK JENA encoders fulfill the requirements of the (German) Product Safety Act (ProdSG) from November 8th, 2011.
- Connect NUMERIK JENA encoders only to subsequent electronics whose power supply is generated from PELV systems (EN 50178).
- NUMERIK JENA encoders fulfill the requirements of standard IEC 61010-1 only if the power is supplied from a secondary circuit with current limitation as per IEC 61010^{3rd Ed.}, Section 9.4 or with power limitation as per IEC 60950-1^{2nd Ed.}, Section 2.5 or from a Class 2 secondary circuit as specified in UL1310.*
- This user manual supersedes all previous editions, which thereby become invalid. The basis for ordering from NUMERIK JENA is always the user manual edition valid when the contract is made.
- Standards (ISO, EN, etc.) apply only where explicitly stated in the user manual.

* In place of IEC 61010-1^{3rd Ed.}, Section 9.4, the corresponding sections of standards DIN EN 61010-1, EN61010-1, UL 61010-1 and CAN/CSA-C22.2 No. 61010-1 can be applied and in place of IEC 60950-1^{2nd Ed.}, Section 2.5 the corresponding sections of standards DIN EN60950-1, EN60950-1, UL60950-1, CAN/CSA-C22.2 No. 60950-1 can be applied.

2.3 Notes on Transport, Storage and Handling



Encoder

- Use the original packaging for transportation only!
- If possible, use the original packaging for storage only.

SINGLEFLEX scale tape

- Can be rolled up (minimum bending radius = 140 mm).
- No restrictions regarding to the length.

DOUBLEFLEX scale tape

- In no case the DOUBLEFLEX scale tape should be stored, transported or used when rolled up!
- Use only the original packaging for transportation!
 - Lengths up to 3 m - stretched out
 - Lengths above 3 m - tape laid down as a figure eight
- Use the original packaging for storage only!
- Damages to the adhesive layer between the scale tape and carrier tape must absolutely be avoided, since otherwise the measuring properties of the DOUBLEFLEX scale tape are lost.
- Only remove the DOUBLEFLEX scale tape from the packaging on site, directly before mounting.
- Do not separate the scale tape and carrier tape from each other! Avoid any unintentional separation of the scale tape from the carrier tape, even just partial separation.
- Avoid radial or axial offsetting between the scale tape and carrier tape.
- **If the scale tape should become partially or completely separated from the carrier tape - even for just a very short time - simply pressing them together again will not result in sufficient adhesion. In this case neither the operational reliability nor the metrological properties can be guaranteed anymore. Please return the scale tape to NUMERIK JENA GmbH for repair! Unfortunately a repair at the customer site is not possible.**
- When removing the DOUBLEFLEX scale tape from the packaging, the sag must not exceed more than 100 mm.
- After removing the greatest distance between two supports must not be more than 800 mm. Scale tapes up to 1,200 mm must be supported approx. 300 mm from the ends and longer scale tapes must be supported correspondingly.

2.4 Notes on Operation



- Do not connect or disconnect plugs if the power is on!
- Only operate the encoder with the supply voltage stated in this product data sheet.
- Comply with applicable PIN assignment if auxiliary electronic units are connected (e.g. controller or display)!
- Integrate exposed encoders in instruments, devices or machines in such a way that these are protected against contamination.
- Protect the scale tape against mechanical damage.
- Protect the scanning head against shock, impact and humidity.

2.5 Notes on Maintenance

- The encoder requires no maintenance whatsoever, but must be cleaned occasionally, depending on the ambient conditions.
- Modifications and repairs of the encoder may only be carried out by NUMERIK JENA GmbH or appropriately authorized persons.
- NUMERIK JENA GmbH is not liable for damages caused by unauthorized handling of the encoder. All warranty claims are forfeited by unauthorized handling.
- Exposed measuring systems are sensitive to contamination, especially the scale surface and the scanning windows for the counting and reference tracks on the scanning head.
- Particularly critical are rough and irregular contamination and deposits (e.g. oil, grease or water).
- The user has to protect the encoder from contamination by way of appropriate design measures.



- **When cleaning the encoder, ensure that no solvent flows under the scale tape!**
- **When cleaning the components, ensure that the scanning window and scale tape are not scratched by any deposited particles!**
- **Please also pay attention to the notes in chapter 9 „Cleaning“.**

3. Functional Elements

3.1 Online Compensation (Offset and Amplitude Control)

Contamination and mounting errors lead to interferences in the optical scanning of the scale by the scanning head and so to periodic deformations of the sinusoidal counting track signals, which are exemplified as

- Offset deviations
- Amplitude deviations
- Amplitude differences between the sine and cosine channels and lead to interpolation errors.

Contaminated Scale Tape

Scanning head signal with contaminated grating disk before activation of the online compensation.

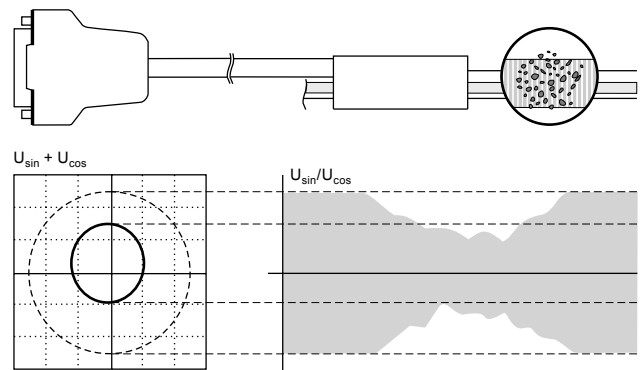

Image 1

Incorrect Mounting

Scanning head signal with faulty mounting before activation of the online compensation.

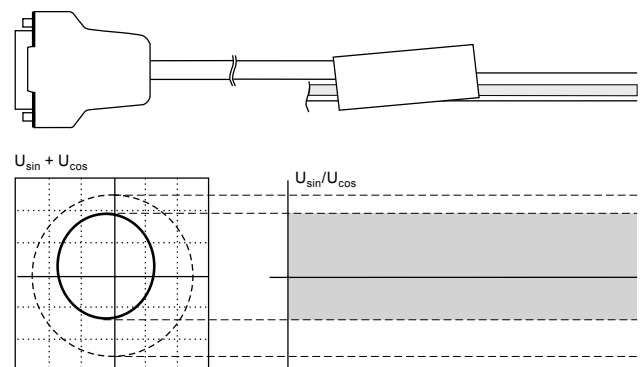

Image 2

Active Online Compensation

Scanning head signal with contaminated grating disk and/or faulty mounting after activation of the online compensation.

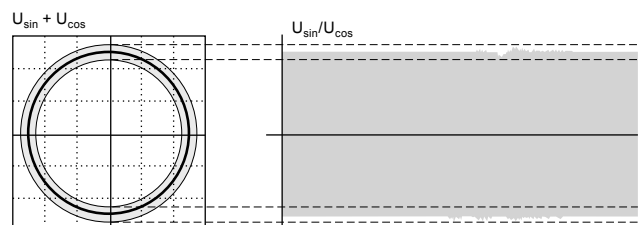

Image 3

Through the offset and amplitude control the signals generated by the measuring module are automatically corrected within the sensor without following error over the entire velocity range.

This measure not only increases the accuracy, but also the reliability of the encoder.

3.2 Switch Sensor

The use of a switch sensors results in no additional switches being needed. This saves cable material and time for installation. The opto-electronic switch sensor integrated in the LIA 21 scanning head can be used

- to detect limit positions with left/right distinction,
- to indicate the scanning head position within the measuring range or
- to enable a reference mark (selection of one reference mark from n marks)

It is also possible to combine these variations.

The switch sensor can be used universally depending on the various output settings (order options):

- TTL low active or TTL high active
- Open Collector low active or Open Collector high active
- MOS relay opening or closing to 300 V switching voltage

3.3 Switch Foil

In order to use the switch signals, a switch foil must also be applied. The guide tape is intended for use as the carrier for the switch foil(s). At least one guide tape is necessary for this. If no guide tapes are used, a reflecting foil must be used as the carrier for the switch foil.

If the scale tape is mounted in a slot or along an edge, the switch foil can be stuck on the machine element together with the reflecting foil.

The surfaces of the switch foil and the scale tape must be at the same level!



First the reflecting foil is glued onto the scale tape carrier over the entire measuring length. Then the switch foil is glued to the reflecting foil.

Whether using guide tapes or the reflecting foil as switch foil carrier, there are two options for mounting the switch foil:

1. Precise Mounting

- Achievable accuracy: ± 1 mm
- Reproducibility of the switch signal: ± 0.1 mm

2. Reference to a Machine Datum

- Minimization of the position deviation of the switch signal with the aid of the evaluation electronics
- Achievable accuracy of the position signal: ± 0.7 mm
- Reproducibility of the switch signal: ± 0.1 mm

4. Technical Data

4.1 Resolution and Accuracy (Definition)

Basically one has to differentiate between the resolution and the accuracy of a measuring system. The two parameters are not directly interdependent and may differ from each other.

Resolution

The resolution of linear system describes the least possible displacement of scanning head against the scale which can still be discerned by the evaluation electronics (display, control). It depends on (see chart 1)

- the graduation period of the scale
- the signal interpolation factor (internally or in auxiliary electronic unit)
- the evaluation mode in the counter

Accuracy

The accuracy of linear measuring systems is specified in accuracy classes.

The extreme error values for any max. one-meter section of the measured length lie within the specified accuracy class of $\pm a \mu\text{m}$ with respect to their mean value.

For measuring length up to 1 m, the tolerance ($\pm a \mu\text{m}$) refers to the actual measuring lengths. The accuracy applies to a reference temperature of 20°C.

With exposed linear measuring systems, the definition of the accuracy class applies only to the scale. This is called scale accuracy.

Grating period of scale tape	Signal period of sinusoidal signals	Interpolation factor	Signal period after interpolation	Resolution after evaluation in counter	
				2-times	4-times
20 μm	20 μm	none	20 μm	10 μm	5 μm
		5-times	4 μm	2 μm	1 μm
		10-times	2 μm	1 μm	0.5 μm
		25-times	0.8 μm	0.4 μm	0.2 μm
		50-times	0.4 μm	0.2 μm	0.1 μm
		100-times	0.2 μm	0.1 μm	0.05 μm

Chart 1

4.2 Mechanical Data

	LIA 20	LIA 21
Dimensions of scan head (in mm)	34 x 13.2 x 12.4	34 x 13.2 x 12.4
Weight of scan head (w/o cable)	≤20 g	≤20 g
Number of switch sensors	none	1
Repetition accuracy of the switch sensors	-	0.1 mm
recommended measuring steps	0.05 μm, 0.1 μm, 0.2 μm, 0.5 μm, 1.0 μm, 5.0 μm	
Traversing speed		
Maximum	10 m/s (without interpolation)	
Depending on the evaluation electronics	see chart 4	
Scale tape		
Material	Stainless Steel	
Grating period (TP)	20 μm	
Reference marks	<ul style="list-style-type: none"> • Periodic at a distance of 50 mm • In the middle of the measuring length (ML) • Distance coded at 1,000 x TP • Others on request 	
Measuring length (ML)		
SINGLEFLEX scale tape	up to 30 m	
DOUBLEFLEX* scale tape	up to 5 m	
Linear thermal expansion coefficient		
SINGLEFLEX scale tape	10.6 x 10 ⁻⁶ K ⁻¹ (expansion will be influenced by the mounting surface)	
DOUBLEFLEX* scale tape	10.6 x 10 ⁻⁶ K ⁻¹	
Accuracy classes (a)		
SINGLEFLEX, DOUBLEFLEX* scale tape	±1 μm ±2 μm ±3 μm ±5 μm	
Cable		
Cable diameter	3.7 mm or 5.1 mm (see ordering key)	
Permissible bending radius	<ul style="list-style-type: none"> • Occasional flexing ~8 mm • Constant flexing ~40 mm 	
From scan head to the D-Sub connector	0.3 m, 0.5 m, 1.0 m, 1.5 m, 2.0 m, 3.0 m (other on request)	
From D-Sub connector to the controller (extension cable)	max. 100 m (The necessary supply voltage must be ensured!)	

* not suitable for vacuum applications

Chart 2

4.3 SINGLEFLEX and DOUBLEFLEX Scale Tape

The steel scale tapes from NUMERIK JENA are available in two different versions:

- SINGLEFLEX
- DOUBLEFLEX (not suitable for vacuum applications)

SINGLEFLEX

The SINGLEFLEX-scale tape consists of a single steel tape with an applied incremental track and one or more reference marks. The scale tape is equipped with a double-sided adhesive tape and can be mounted easily on the machine element.

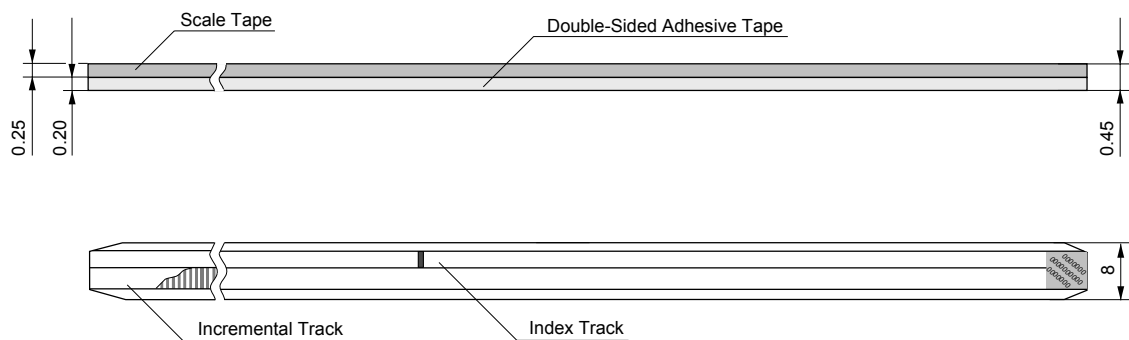

Image 4

DOUBLEFLEX

The DOUBLEFLEX-scale tape consists of two superimposed steel tapes. Both of them are divided by a tension uncoupled sheen of oil which ensures the adhesion between the steel tapes. The incremental track and one or more reference marks are applied on the upper steel tape. The lower steel tape is equipped with a double-sided adhesive tape and can be mounted easily on the machine element.

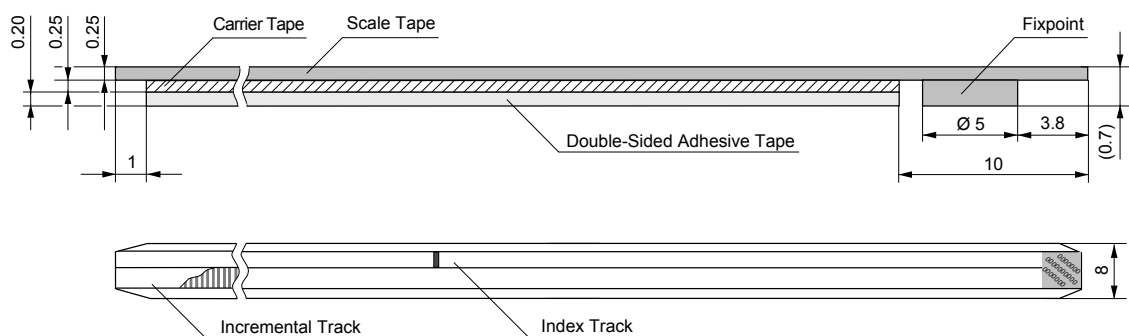

Image 5

The two steel tapes are uncoupled mechanically. This ensures that the upper steel tape can expand independently of the lower steel tape due to thermal variations of the ambient temperature. By reference of the ambient temperature and the expansion coefficient of the steel tape it is possible to determine occurring length deviation of the increments. This allows to subtract out the deviation of the measurement results.

4.4 Guide Tape and Mounting Tool (FAV)

Scale Tape with Guide Tape

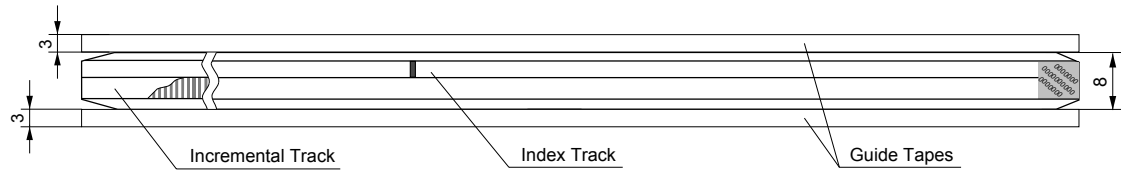

Image 6

Guide Tape Mounting Tool FAV*

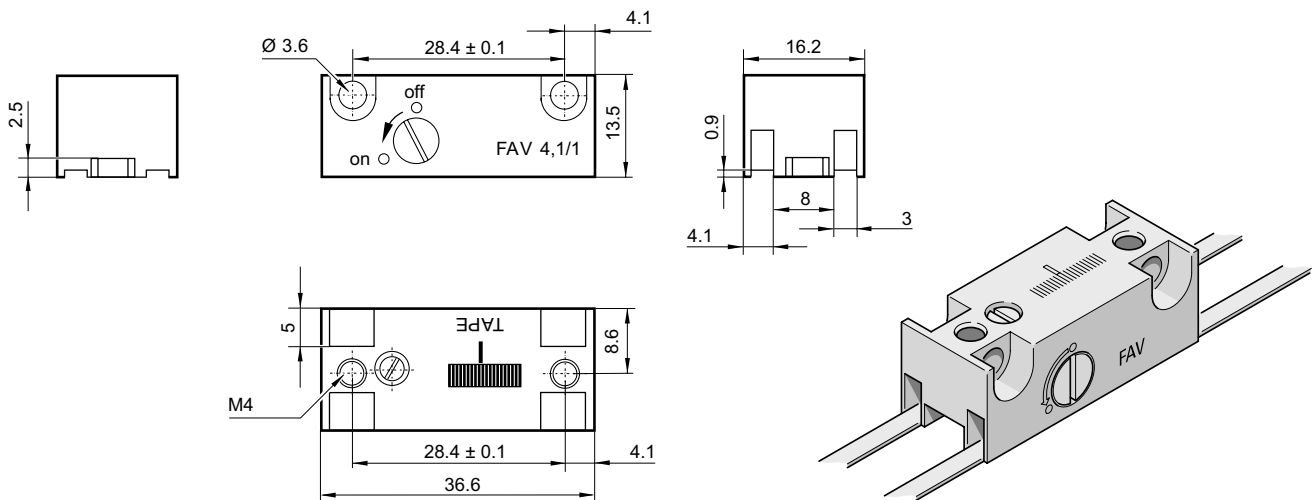

Image 7

* NUMERIK JENA- / DR. JOHANNES HEIDENHAIN - patents DE 19700367 and US 6,049,992 as well as patents EP0388453, JP2837483 and US5,063,685 under restricted licence from Renishaw plc.

4.5 QUICK GUIDE

Mounting gadget for linear scales:

- Allows an easy assembly or exchange of the grating scale
- For scale tapes with accuracy class $\pm 5 \mu\text{m}$
- Maximum length: 2.0 m (other on request)
- Usable for the following models: LIA 20, 21

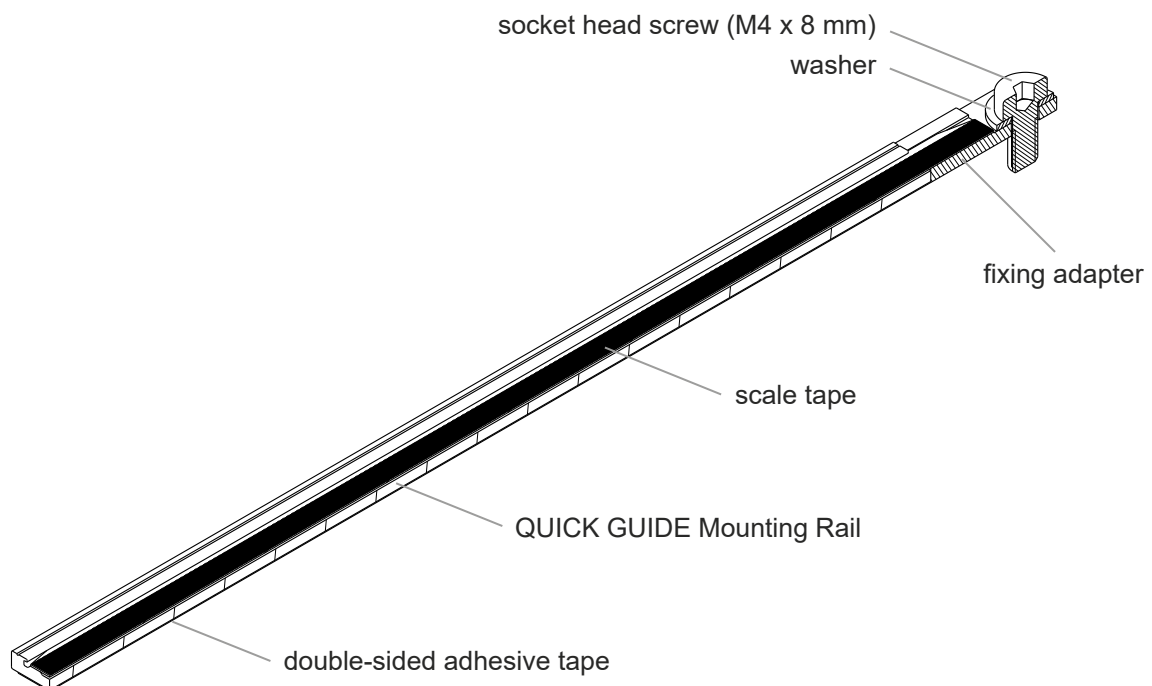

The QUICK GUIDE allows you to mount your scale tape on your machine ground in a new way. The advantage is that the scale tape can expand due to thermal influences easily without the incurrance of tensions and it is possible to change the scale tape very simple without any residues.

4.6 QUICK GUIDE Mounting Tool

The optional QUICK GUIDE Mounting Tool will be mounted in place of the LIA - read head and eases the mounting of the QUICK GUIDE Mounting Rail. Additionally a precise and to the guideway parallel running mounting of the rail will be ensured.

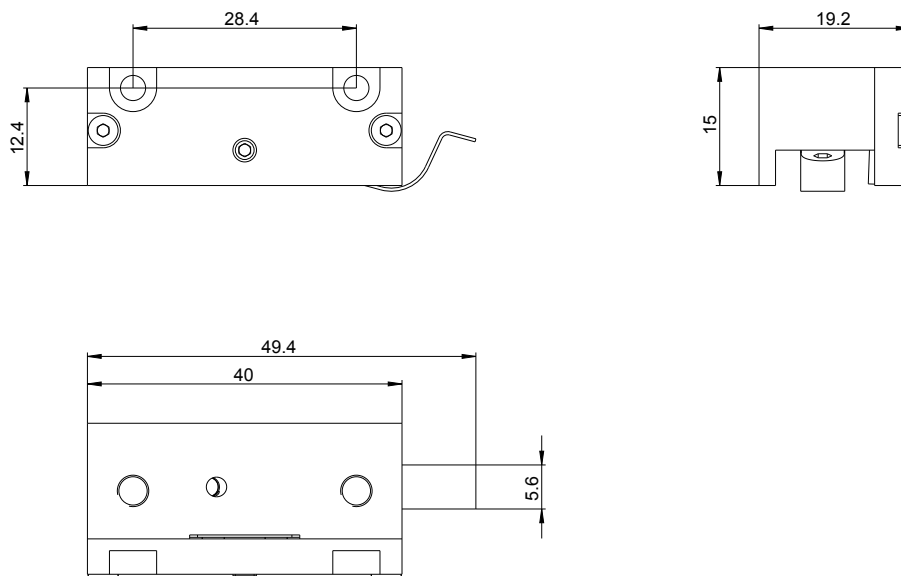

(specification in mm)

4.7 Electrical Data

	LIA 20	LIA 21	
Scanning frequency	max. 500 kHz		
Supply voltage	5 V \pm 10%		
Output interfaces			
Voltage output	1 V _{PP}		
Square wave output	RS 422 with interpolation up to 100-times		
Current consumption			
Voltage output	≤ 90 mA*	≤ 100 mA*	
Square wave output	≤ 220 mA*	≤ 230 mA*	
Output interfaces for switch signals (LIA 21)			
TTL	high active	Output voltage	$U_{\text{out high}} \geq 2.4$ V $U_{\text{out low}} \leq 0.4$ V
	low active		
Open Collector	high active	Output current	$I_{\text{out high}} \leq 1$ mA $I_{\text{out low}} \leq -16$ mA $P_{\text{max}} = 24$ mW
	low active	Max. power loss	
MOS Relais	N/C contact	Max. switch voltage	$U_{\text{max}} = 300$ V $I_{\text{max}} = 0.1$ A $P_{\text{max}} = 300$ mW
	N/O contact	Max. switch current Max. power loss	

* with 120 Ω load resistance

Chart 3

4.8 Switch-On Behaviour



During power-up procedure of the encoder system the level of power voltage and signal lines must be below 250 mV.

If the encoder system will be powered-up at a residual voltage between a range of 250 and 400 mV, internal sensor parameter will not set correctly. This will lead to incorrect encoder signals.

This behaviour has to be observed especially during reset routines of controllers.

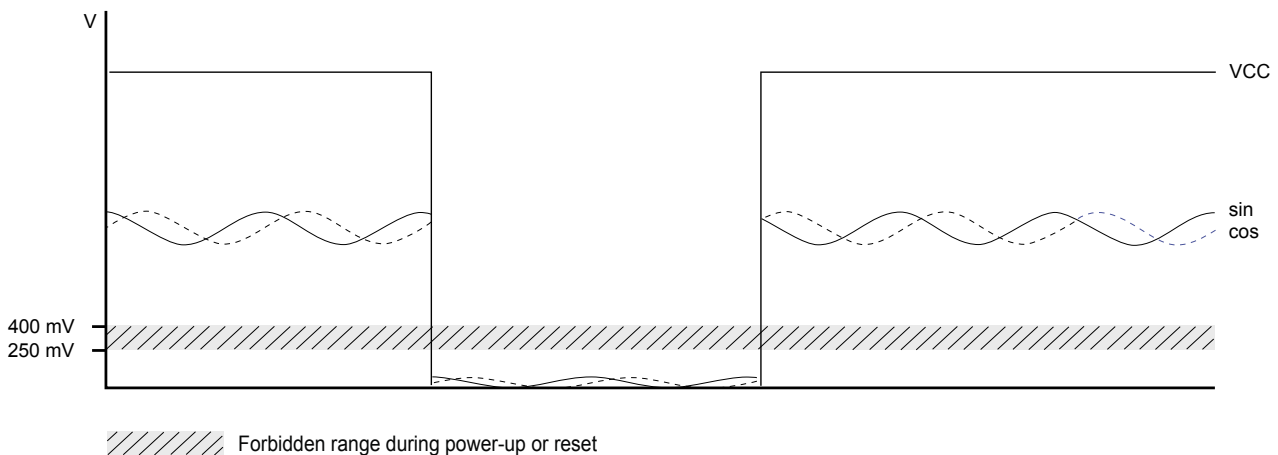

Image 8

4.9 Attainable Traversing Speed

The maximum attainable traversing speed of the encoder is determined by the maximum output frequency of the interpolator and/or the maximum counting frequency of the operator's evaluation electronics.

In order to avoid counting errors, the interpolator's output frequency is matched to the counting frequency of the operator's evaluation electronics.

This adaptation is possible in discrete frequency steps.

The maximum attainable traversing speed (v_{\max}) is calculated according to the following formula:

$$v_{\max} = \frac{f \cdot TP}{i \cdot SF \cdot 4} \quad [\text{m/s}]$$

f	Clock frequency of the counter [MHz]
TP	Grating period [μm]
i	Interpolation factor (5-times, 10-times, 25-times, 50-times or 100-times)
SF	Safety factor = 1.5
4	4-edge evaluation

v_{\max} dependent on the interpolation factor and the clock frequency of the counter

Interpolation	w/o	5-times		10-times		25-times		50-times		100-times	
Resolution (μm)	5	1		0.5		0.2		0.1		0.05	
Min. clock frequency of the counter (MHz)	2	4	16	4	24	4	24	4	24	4	24
Min. edge separation (μs)	0.5	0.25	0.063	0.25	0.042	0.25	0.042	0.25	0.042	0.25	0.042
Max. traversing speed (m/s)	10	2.66	10	1.33	8	0.53	3.2	0.27	1.6	0.13	0.8

• with 4-edge evaluation

Chart 4

4.10 Ambient Conditions

	LIA 20	LIA 21
Operating temperature range	0°C to +55°C (+32°F to +131°F)	
Storage temperature range	-20°C to +70°C (-4°F to +158°F)	
Vibration (50 Hz ... 2,000 Hz)	$\leq 200 \text{ ms}^{-2}$ (20 g)	
Shock (11 ms)	$\leq 400 \text{ ms}^{-2}$ (40 g)	
Humidity	93% relative humidity (no condensation forming)	

Chart 5

4.11 Cable

Scanning Head Cable (connection cable from scanning head to D-Sub connector)

- Please mount the scanning head preferably on the rigid part and the scale tape on the mobile part of the machine. If this is not possible, provide a strain relief for the cable near the scanning head.
- The encoder cables and connecting cables must be laid away from sources of interference (e.g. mains cables, fuses, motors, magnetic valves or power supplies). Normally a distance of $\geq 100 \text{ mm}$ will be sufficient.
- Install the cable in a way that it cannot be damaged by the moving carriage. Please pay attention to the permissible bending radius (see also point 4.2)!

Extension Cable (connection cable from D-Sub connector to controller)

- Use preferably original extension cables made by NUMERIK JENA. This guarantees an optimum compatibility with the encoders and ensures a maximum protection against electromagnetic interferences.
- Please consult the technical support of NUMERIK JENA before using selfmanufactured extension cables.
- Do not install any other signal lines in the encoder cable!

4.12 Connector Variants

Type	Image connector	Pins
15-pin D-Sub		
9-pin D-Sub		
12-pin round connector (Plastic-coated connector)		
12-pin round connector (Plastic-coated coupling)		

Chart 6

4.13 PIN Assignment

LIA 20 - 15-pin D-Sub Connector

PIN	1	2	3	4	5	6	7	8	9	10	11	12	13	14	15	Housing
1 V _{PP}	-	-	-	U ₀₋	U ₂₋	U ₁₋	-	5V	0V	-	-	U ₀₊	U ₂₊	U ₁₊	Inner shield	Outer shield
RS 422	-	-	NAS	Z ₀₋	Z ₂₋	Z ₁₋	-	5V	0V	-	AS	Z ₀₊	Z ₂₊	Z ₁₊	Inner shield*	Outer shield
Cable Ø 3.7 mm	-	-	vt	pk	rd	bn	-	bu	wh	-	ye	gy	bk	gn	-	-
Cable Ø 5.1 mm	-	-	vt	pk	rd	ye	-	bn	wh	-	bk	gy	bu	gn	wh/gy	-

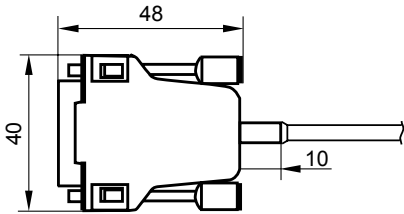
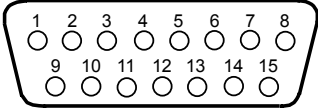
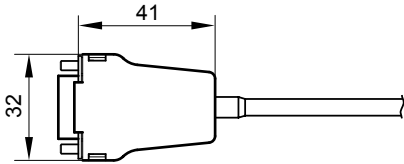
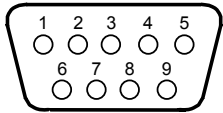
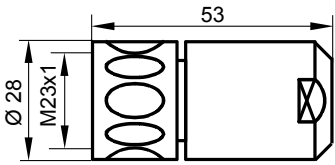
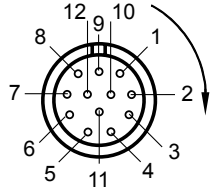
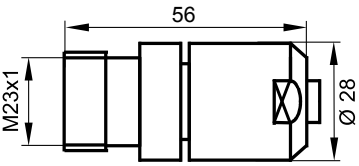
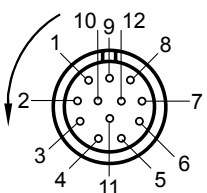
* for signal processing in the 15-pin D-sub connector

LIA 20 - 9-pin D-Sub Connector

PIN	1	2	3	4	5	6	7	8	9	Housing
1 V _{PP}	U ₁₋	0V	U ₂₋	Inner shield*	U ₀₋	U ₁₊	5V	U ₂₊	U ₀₊	Outer shield
RS 422	Z ₁₋	0V	Z ₂₋	NAS	Z ₀₋	Z ₁₊	5V	Z ₂₊	Z ₀₊	Outer shield
Cable Ø 3.7 mm	bn	wh	rd	vt	pk	gn	bu	bk	gy	-
Cable Ø 5.1 mm	ye	wh	rd	vt	pk	gn	bn	bu	gy	-

* in the case of 1 V_{PP} the violet wire remains unused, the inner shield (extended with wire color white/green) will be connected instead

LIA 20 - 12-pin Round Connector

PIN	1	2*	3	4	5	6	7	8	9	10*	11*	12*	Housing
1 V _{PP}	U ₂₋	5V	U ₀₊	U ₀₋	U ₁₊	U ₁₋	-	U ₂₊	Inner shield	0V	0V	5V	Outer shield
RS 422	Z ₂₋	5V	Z ₀₊	Z ₀₋	Z ₁₊	Z ₁₋	NAS	Z ₂₊	-	0V	0V	5V	Outer shield
Cable Ø 3.7 mm	rd	bl	gy	pk	gn	bn	vt	bk	wh/gn	wh	wh	bu	-
Cable Ø 5.1 mm	rd	bn	gy	pk	gn	ye	vt	bu	-	wh	wh	br	-

* PIN 2 and 12 bridged, PIN 10 and 11 bridged

LIA 21 - 15-pin D-Sub Connector

PIN	1	2	3	4	5	6	7*	8	9	10*	11	12	13	14	15	Housing
1 V _{PP}	-	-	-	U ₀₋	U ₂₋	U ₁₋	-	5V	0V	S1	-	U ₀₊	U ₂₊	U ₁₊	Inner shield	Outer shield
RS 422	-	-	NAS	Z ₀₋	Z ₂₋	Z ₁₋	-	5V	0V	S1	AS	Z ₀₊	Z ₂₊	Z ₁₊	Inner shield	Outer shield
Cable Ø 5.1 mm	-	-	vt	pk	rd	ye	-	bn	wh	-	bk	gy	bu	gn	wh/gn	-

* for switch sensors with TTL- or Open Collector output:

S1 connected with PIN 10,

* for switch sensors with relay output:

S1 connected with PIN 7 and 10

1 V_{PP}

U₁₊ Counting signal 0° (sin)
 U₁₋ Counting signal 180° (-sin)
 U₂₊ Counting signal 90° (cos)
 U₂₋ Counting signal 270° (-cos)
 U₀₊ Reference signal
 U₀₋ Neg. reference signal

RS 422

Z₁₊ Counting signal 0°
 Z₁₋ Neg. counting signal 0° (180°)
 Z₂₊ Counting signal 90°
 Z₂₋ Neg. counting signal 90° (270°)
 Z₀₊ Reference signal
 Z₀₋ Neg. reference signal

0V Ground (GND)

5V Operating voltage (U_B)

AS Error signal (monitoring signal)

NAS Neg. error signal

NAS high: Input signal within the tolerance range

NAS low: Input signal outside the tolerance range (check measuring system!)

SCL Programming wire clock

SDA Programming wire data

4.14 PIN Assignment for JST Miniature Connector

LIA 20 - 10-pin JST Miniature Connector

PIN	1	2	3	4	5	6	7	8	9	10	
1 V _{PP}	U ₂₋	0V	-	U ₂₊	U ₀₋	-	U ₁₋	U ₀₊	U ₁₊	5V	Inner shield
RS 422	Z ₂₋	0V	NAS	Z ₂₊	Z ₀₋	AS	Z ₁₋	Z ₀₊	Z ₁₊	5V	-
Cable Ø 3.7 mm	rd	wh	vt	bk	pk	ye	bn	gy	gn	bu	-
Cable Ø 5.1 mm	rd	wh	-	bu	pk	-	ye	gy	gn	bn	wh/gn

LIA 21 - 14-pin JST Miniature Connector

PIN	1	2	3	4	5	6	7	8	9	10	11	12	13	14	
1 V _{PP}	0V	U ₁₋	-	SCL	SDA	-	U ₁₊	U ₀₊	U ₂₋	5V	U ₂₊	U ₀₋	S2	S1	Inner shield
RS 422	0V	Z ₁₋	NAS	SCL	SDA	-	Z ₁₊	Z ₀₊	Z ₂₋	5V	Z ₂₊	Z ₀₋	S2	S1	
Cable Ø 5.1 mm	wh	ye	vt	bk	bn/gn	-	gn	gy	rd	bn	bu	pk	wh/ye	ye/bn	wh/gn

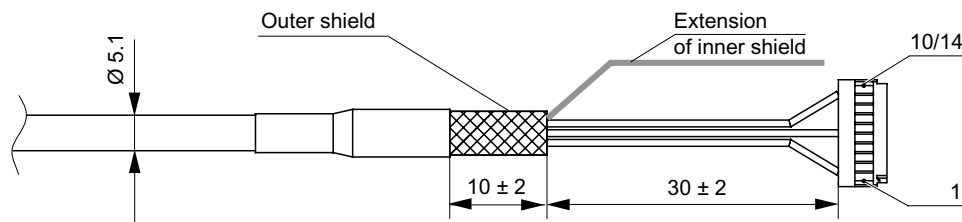

Image 9

1 V_{PP}

U ₁₊	Counting signal 0° (sin)
U ₁₋	Counting signal 180° (-sin)
U ₂₊	Counting signal 90° (cos)
U ₂₋	Counting signal 270° (-cos)
U ₀₊	Reference signal
U ₀₋	Neg. reference signal

RS 422

Z ₁₊	Counting signal 0°
Z ₁₋	Neg. counting signal 0° (180°)
Z ₂₊	Counting signal 90°
Z ₂₋	Neg. counting signal 90° (270°)
Z ₀₊	Reference signal
Z ₀₋	Neg. reference signal

0V	Ground (GND)
5V	Operating voltage (U _B)
AS	Error signal (monitoring signal)
NAS	Neg. error signal
	NAS high: Input signal within the tolerance range
	NAS low: Input signal outside the tolerance range (check measuring system!)
SCL	Programming wire clock
SDA	Programming wire data

4.15 Electromagnetic Compatibility (EMC)



Please observe the following to ensure maximum protection against electrical and magnetic fields:

- The encoder must be mounted to a galvanic conductive surface. The mounting surfaces, the threads of the mounting screws and the threads in the machine must be free from electrically non-conductive coatings.
- Maintain the NUMERIK JENA shielding concept for the measuring system!
- Shielding for encoders without connectors:
 - When connected directly with the evaluation electronics, ensure that the external shield of the cable is well grounded
 - If cable connectors (e.g. terminal strips, etc.) are used, connect the external shields of the cables with each other and with the shielding of the cable connector
- When using additional electronics, connect the housing electrically conducting to ensure good galvanic conductivity. For insulated installation the housing should be connected at the shortest distance by an additional potential equalization line (Cu line with cross section $\geq 6 \text{ mm}^2$) with the machine's protective ground.
- Please contact the NUMERIK JENA support or that of the appropriate manufacturer if you experience any problems when working with specific display or control units.

4.16 Shielding Concepts

LIA	Abbildung
<p>1 V_{pp} output</p> <p>Signal processing in the scanning head</p>	 <p>Scanning head</p> <p>Outer shield</p> <p>Inner shield</p> <p>Encoder cable Ø 5.1 mm</p> <p>Subsequent electronics</p> <p>15 pin D-Sub connector = Pin 15</p> <p>9 pin D-Sub connector = Pin 4</p> <p>12 pin round connector = Pin 9</p> <p>0 V</p>
<p>RS 422 output</p> <p>Signal processing in the scanning head</p>	 <p>Scanning head</p> <p>Shield</p> <p>Encoder cable Ø 3.7 mm</p> <p>Subsequent electronics</p> <p>0 V</p>
<p>1 V_{pp} output</p> <p>Signal processing in the connector with extension cable</p>	 <p>Scanning head</p> <p>Outer shield</p> <p>Inner shield</p> <p>Encoder cable Ø 5.1 mm</p> <p>Extension cable</p> <p>Subsequent electronics</p> <p>15 pin D-Sub connector = Pin 15</p> <p>9 pin D-Sub connector = Pin 4</p> <p>12 pin round connector = Pin 9</p> <p>0 V</p>
<p>RS 422 output</p> <p>Signal processing in the connector with extension cable</p>	 <p>Scanning head</p> <p>Outer shield</p> <p>Inner shield</p> <p>Encoder cable Ø 5.1 mm</p> <p>Extension cable</p> <p>Subsequent electronics</p> <p>0 V</p>

Chart 7

4.17 Voltage Output $1 V_{PP}$

Optimal Connection Circuit

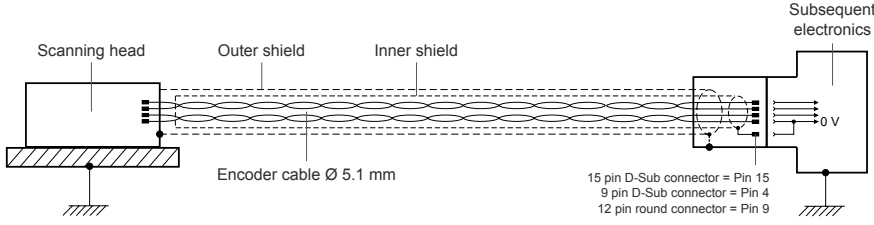
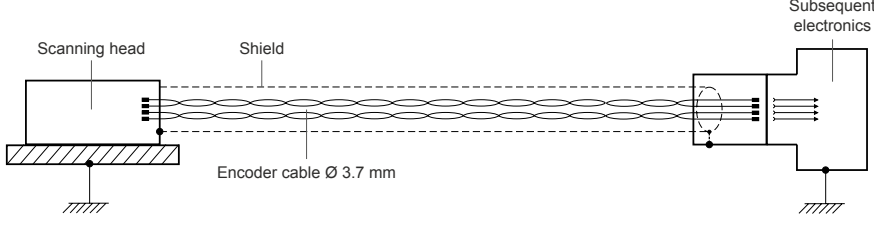
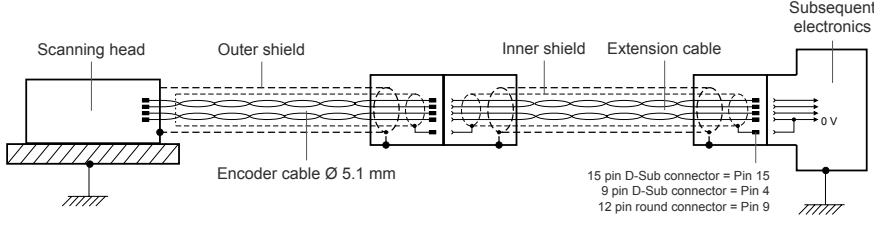
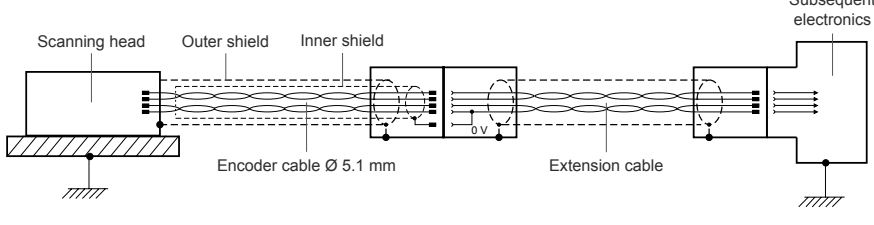
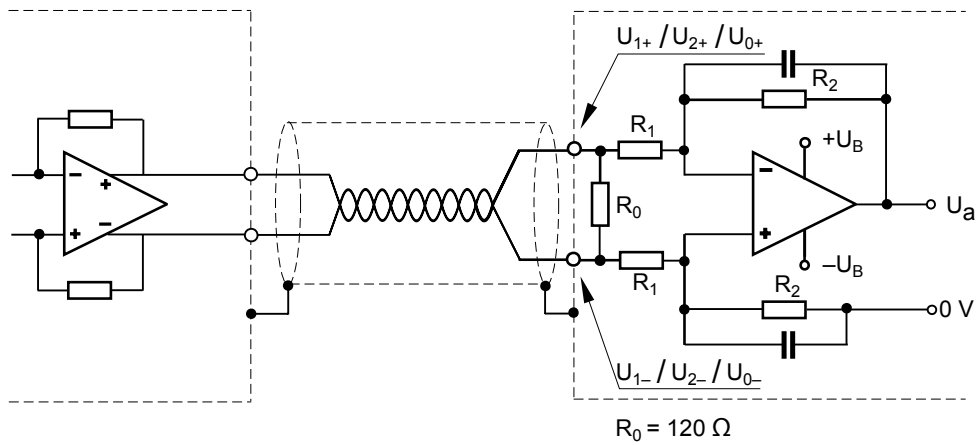

Image 10

Signal Curve

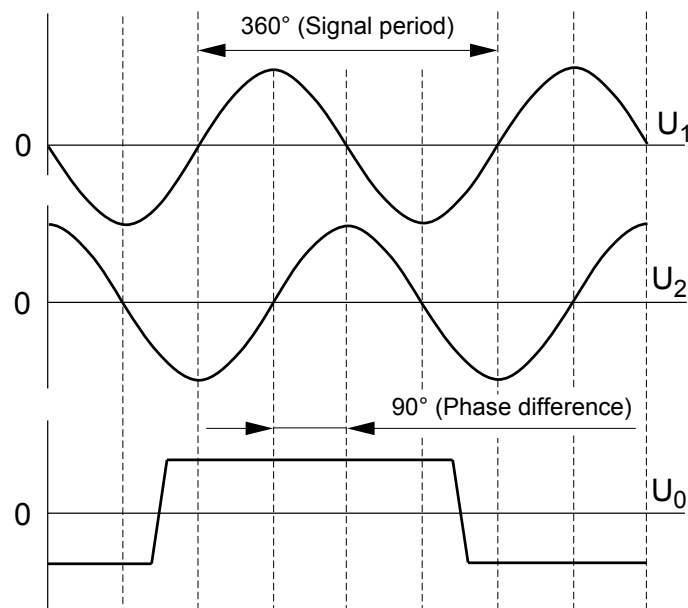

Image 11

Difference signals measured at R_0 :

$$U_1 = U_{1+} - U_{1-} = 0.6 \dots 1.2 V_{PP} \quad (\text{Rated voltage: } 1 V_{PP})$$

$$U_2 = U_{2+} - U_{2-} = 0.6 \dots 1.2 V_{PP} \quad (\text{Rated voltage: } 1 V_{PP})$$

$$U_0 = U_{0+} - U_{0-} = 0.5 \dots 1.2 V \quad (\text{Rated voltage: } 0.8 V)$$

4.18 Square-Wave Output RS-422

Optimal Connection Circuit

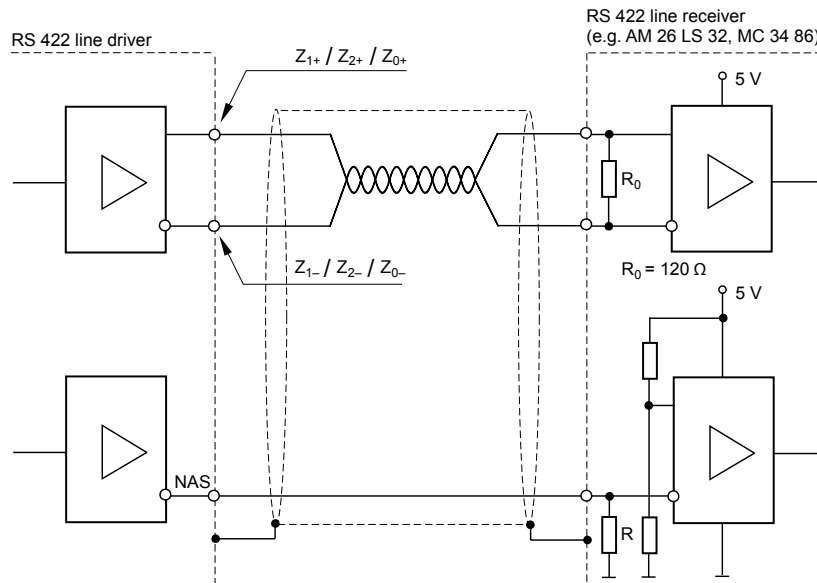

Image 12

Signal Curve

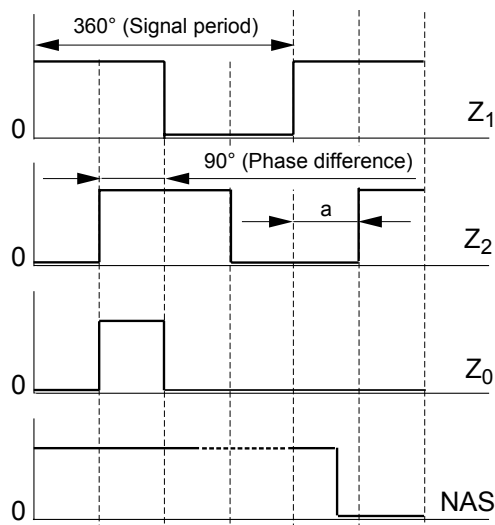

Image 13

NAS high:

Encoder functioning properly, input signals within tolerance range

NAS low:

Check the measuring system

a:

Minimum edge separation as a function of the interpolation factor and traversing speed (see point 4.5)

In order to avoid electromagnetic interference, the cable adaptation with a terminal resistor of $R_0 = 120 \Omega$ is necessary. When connecting more than one parallel signal input to an encoder output signal (e.g. linear motors with parallel connection to position controller, speed controller or acceleration controller) ensure that the resulting terminal resistance of these inputs is $R_{0res} \approx 120 \Omega$.

4.19 Switch Sensor TTL

Optimal Connection Circuit

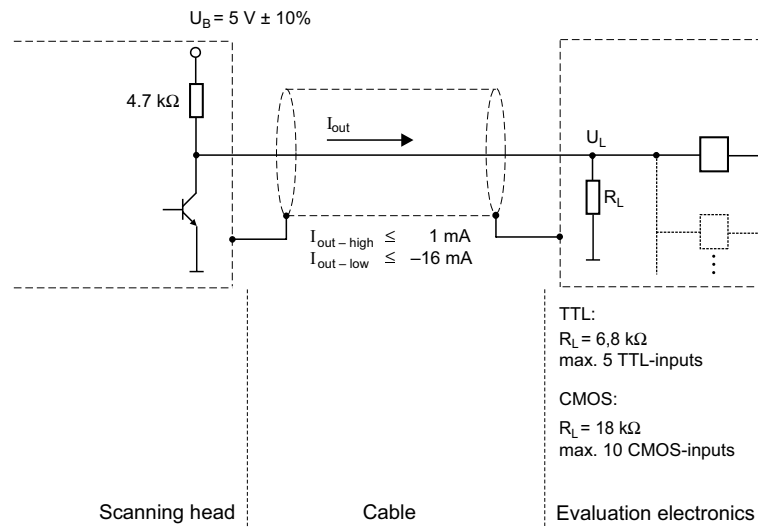

Image 14

Signal Curve

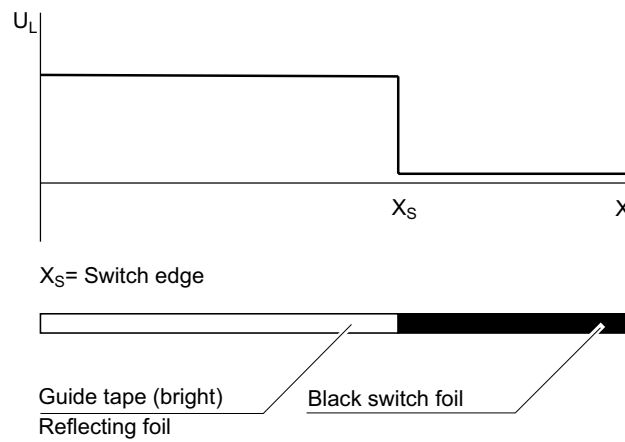

Image 15

4.20 Switch Sensor MOS-Relay LIA 21

Output circuitry of the switch signals for LIA 21

for RS 422 without interpolation and for sinus signal $1 V_{pp}$ or RS 422 with interpolation



Electrically isolated switch contact

Max. switch voltage (DC or AC):	$U_{a \max}$	=	300 V
Max. continuous current:	I_{\max}	=	0.1 A
Max. power loss:	P_{\max}	=	300 mW

Image 16

4.21 Switch Sensor Open Collector

Optimal Connection Circuit

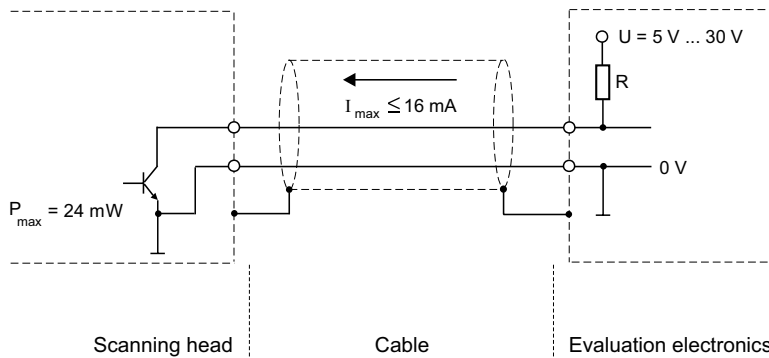

R_{\min} (5 V)	≥	330 Ω
R_{\min} (12 V)	≥	750 Ω
R_{\min} (24 V)	≥	1,5 kΩ
P_{\max}	=	max. power loss

Image 17

Under all circumstances, avoid a short circuit of the Open Collector output with the supply voltage U. The encoder could be destroyed if there is a short circuit!



4.22 Connection Circuits for JST Miniature Connector

The measuring systems from NUMERIK JENA provide the possibility to adjust the signals electronically after mounting. This is useful for signal optimization regarding to the individual mounting conditions. The necessary diagnostic socket is usually located on the PCB inside the 15-pin D-sub connector or inside the scanning head.

If you use a system variant with a JST miniature connector this diagnostic socket will not be included in the delivery content!

In order to adjust the signal nevertheless, we recommend to do it like it is shown in the following scheme. The connection between the adjusting device ("ADJUSTMENT TOOL") and the PCB is done with an 8-pin plug connector (connected to a diagnostic cable), which is included with the adjusting device.

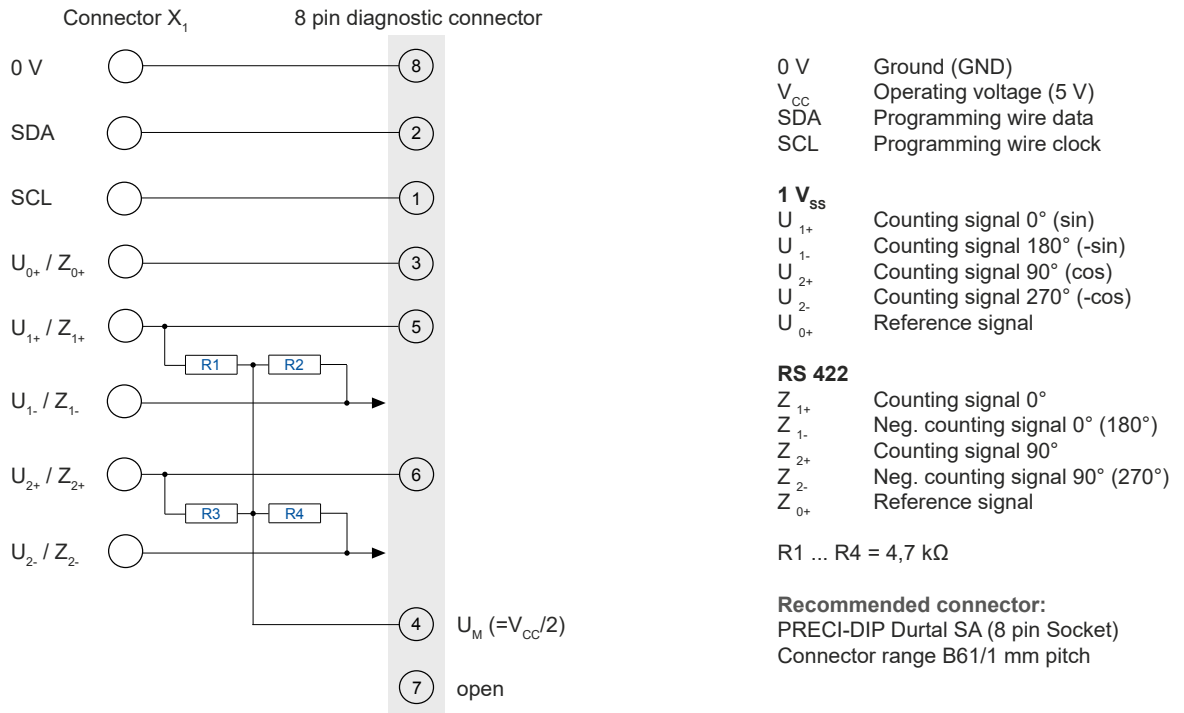

Image 18

Optimal Circuit for Power Supply

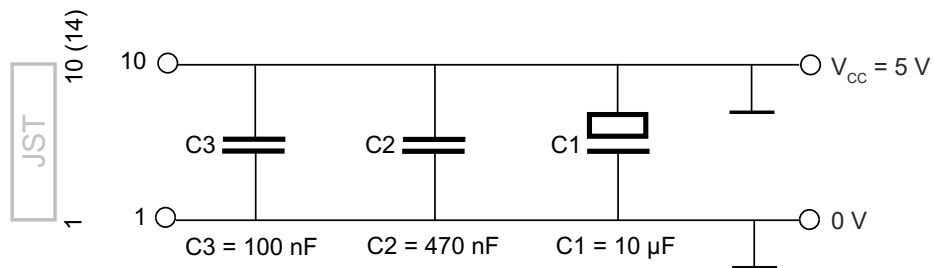

Image 19

5. General Installation Notes

5.1 Delivery Contents

Standard

- LIA 20 or LIA 21 scanning head (according to the ordered specification)
- Mounting screws (M3) for the scanning head (only for scanning heads with through holes)
- SINGLEFLEX or DOUBLEFLEX scale tape (according to the ordered specification)
- Black switch foil (included with LIA 21 only)
- Spacing gage for mounting the scanning head (made of plastic with marking „0.6“)
- Information sheet

Optional

- Guide tapes for SINGLEFLEX or DOUBLEFLEX scale tape (according to the ordered specification)
- Guide tape mounting device (FAV)
- Spacing gage for guide-tape applicator (made of steel with marking „FAV“)
- Extension cable
- Reflecting foil (if guide tapes are not used)

5.2 Installation Position



- The installation position of the measuring system is arbitrary.
- In order to avoid contamination deposits, a vertical position for the scale tape is recommended.
- The operator of the measuring system is responsible for appropriate design measures to protect the encoders from contamination.
- The counting direction of the encoders is positive (increasing measuring values) in any case if the scanning head opposite the scale tape moves in the direction of the cable outlet.
- In any installation position the scale tape surface and scanning window of the scanning head should be easily accessible for cleaning. Prevent contamination and foreign elements from having an influence on the operation!
- If there is no edge or slot for guiding the scale tape, then guide tapes from NUMERIK JENA are recommended. Use the Guide tape mounting device “FAV” to apply the guide tapes.
- The NUMERIK JENA guide tapes are suitable for both SINGLEFLEX and DOUBLEFLEX scale tapes.

- Whereas SINGLEFLEX and DOUBLEFLEX scale tapes have different thicknesses, the thicknesses of the guide tapes are adapted to the scale tapes:
 - for DOUBLEFLEX scale tape: $d = 0.7 \text{ mm}$
 - for SINGLEFLEX scale tape: $d = 0.5 \text{ mm}$
- Please ensure that the guide tapes for DOUBLEFLEX scale tapes are not used for SINGLEFLEX scale tapes and vice versa.
- The guide tapes, slots or edges serve as an installation orientation for straight mounting of the scale tapes, particularly very long ones.
- For DOUBLEFLEX scale tapes, slots and edges also serve as a stop to prevent any displacement between the scale tape and the carrier tape.
- The measuring properties of the DOUBLEFLEX scale tape are the result of the adhesive layer between the scale tape and the carrier tape. Do not displace the scale tape and carrier tape relative to each other, or separate them from each other!
- If you mount the DOUBLEFLEX scale tape vertically, the fixing point must be located at the top. Otherwise the scale tape can detach itself from the carrier tape!
- If you mount the DOUBLEFLEX scale tape perpendicular, the scale tape must lie on the carrier tape.

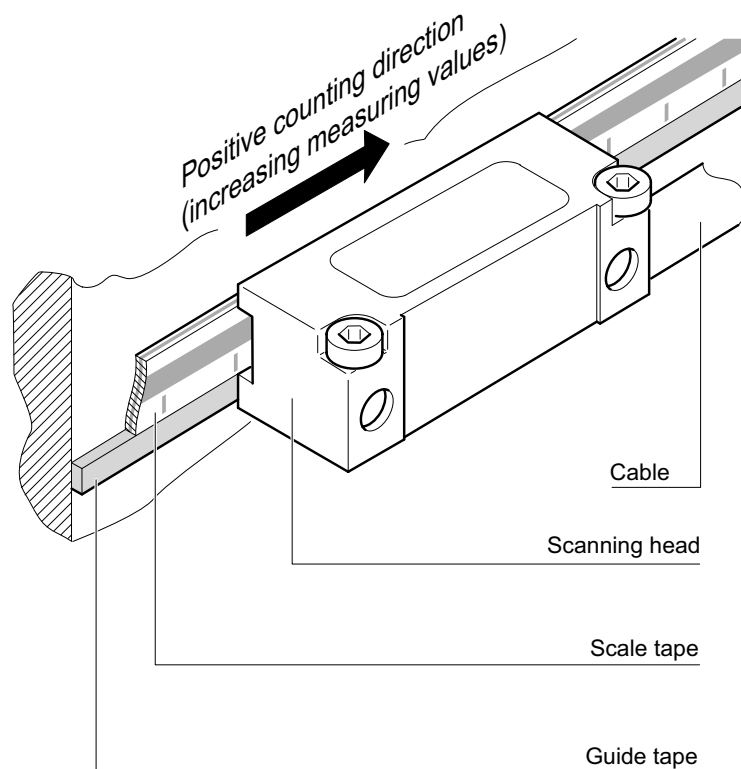

Example:

Vertical position of the surface of a DOUBLEFLEX scale tape without slot or edge, with one guide tape

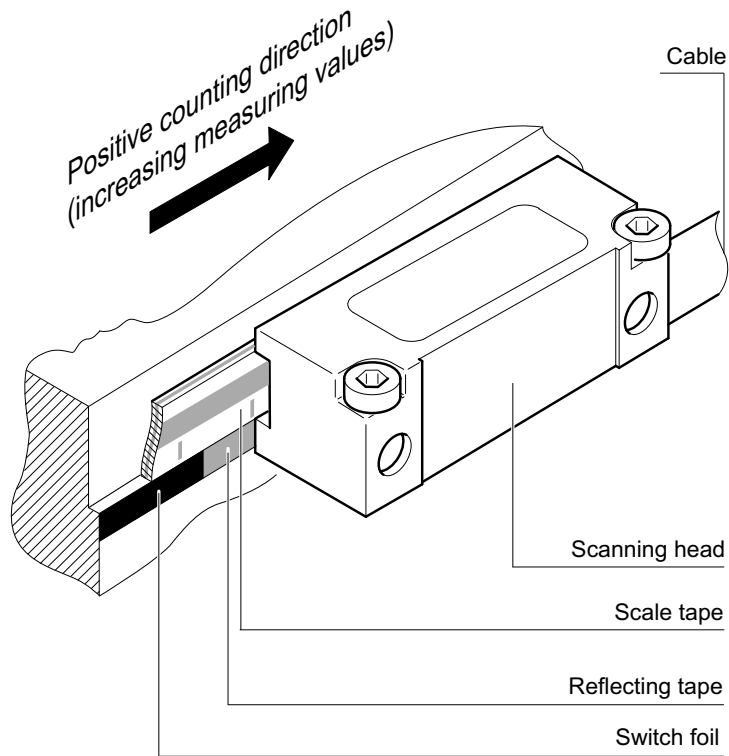
**Example:**

Vertical position of the surface of a DOUBLEFLEX scale tape on an edge, with reflecting tape and switch foil

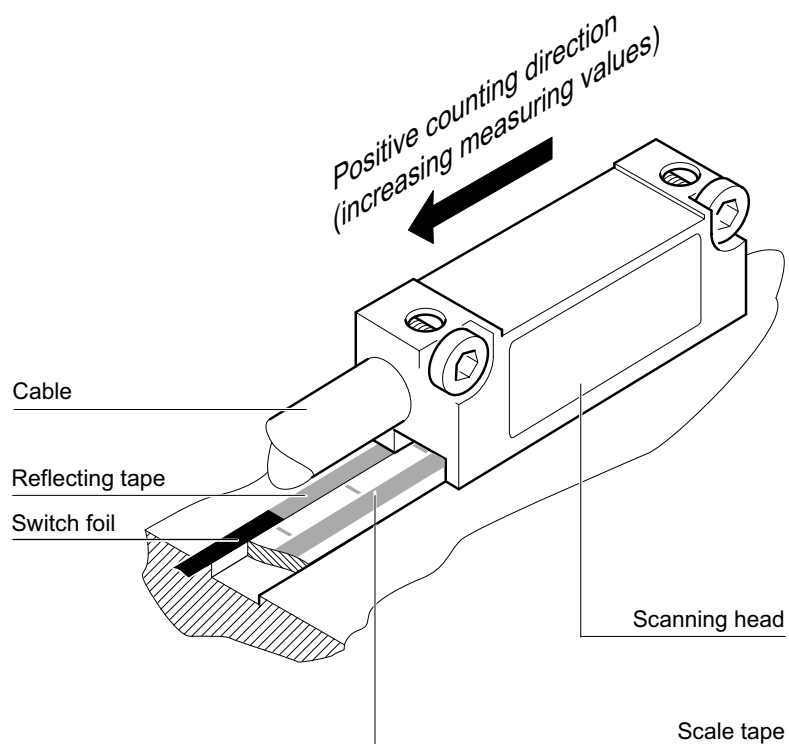
**Example:**

Horizontal position of the surface of a SINGLEFLEX scale tape in a slot, with reflecting tape and switch foil

5.3 Scale Tape Position

- Before mounting, mark the future location of the scale tape.
- The alignment of the scale tape depends on the installation position of the scanning head.
- Please ensure that the scanning head's scanning fields for the counter and reference tracks are over the corresponding tracks on the scale tape.

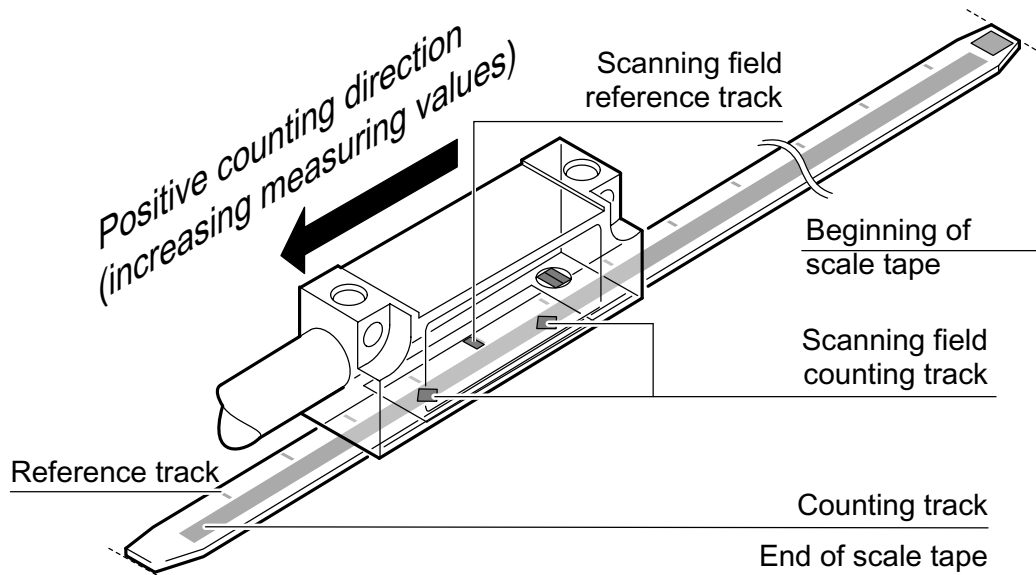

5.4 Mounting Surfaces for Scanning Head and Scale Tape

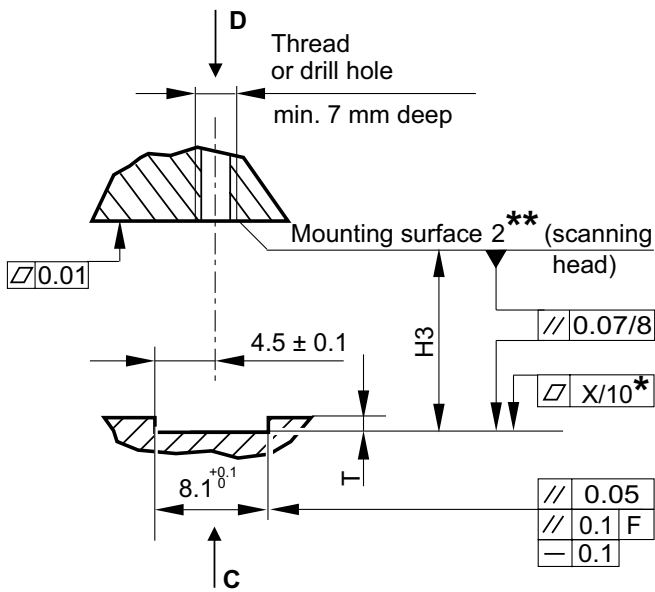

M3 when screwed from side A for LIA 20 / 21

Ø 4,6 when screwed from side B for LIA 20 / 21

Scale tape type	T
SINGLEFLEX scale tape	0.4 _{-0.05}
DOUBLEFLEX scale tape	0.7 _{-0.1}

Accuracy class	X
±1 µm	0.003
±2 µm	0.006
±3 µm	0.009
±5 µm	0.009

M3 when screwed from side C for LIA 20 / 21

Ø 4.6 when screwed from side D for LIA 20 / 21

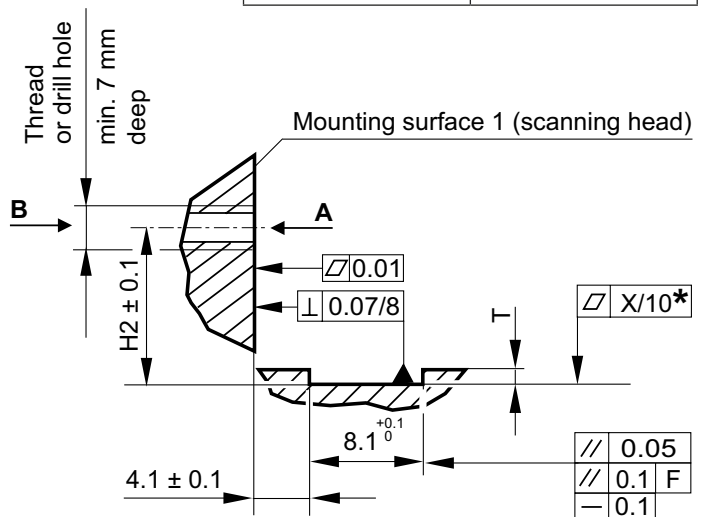

*	Deviation X per 10 mm of the scale tape length
**	The mounting surface 2 must be vertically adjustable to ensure that the distance parameter H1 ±0.1 and the parallelism 0.025 can be achieved

Grating period (TP)	H2		H3	
	SINGLEFLEX scale tape	DOUBLEFLEX scale tape	SINGLEFLEX scale tape	DOUBLEFLEX scale tape
20 µm	10.9 mm	11.1 mm	13.5 mm	13.7 mm

5.5 Mounting Steps



Hereafter the mounting steps for a LIA measuring system from NUMERIK JENA will be described. The mounting steps are showing the mounting of components which are included in the delivery content together with optional components.

- Please read the notes mentioned to the particular mounting steps thorough and follow the indicated sequence of mounting steps exactly!
- The mounting steps for the LIA 20 and LIA 21 are basically the same.
- Maintain a tightening torque of 1 Nm for all screws!

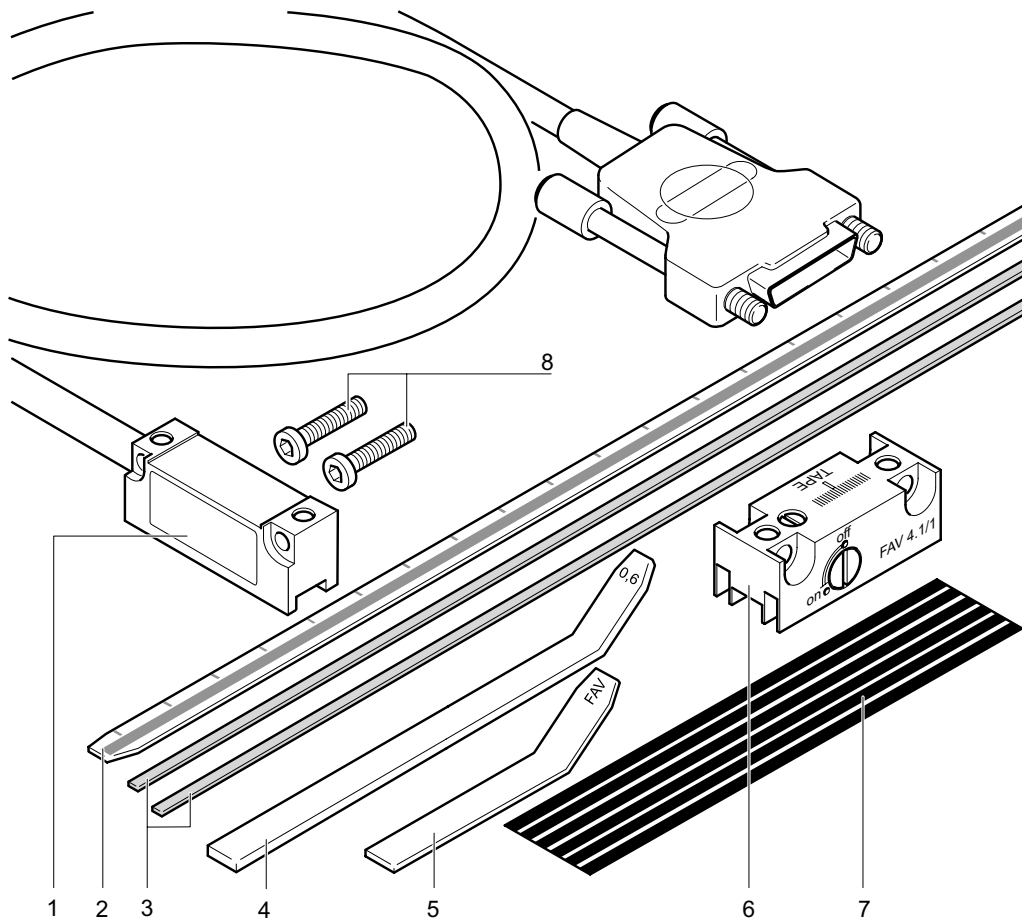

- 1 Scanning head with cable and connector
- 2 Scale tape
- 3 Guide tapes (optional)
- 4 Spacing gage for scanning head with the marking „0.6“
- 5 Spacing gage for the guide tape mounting tool „FAV“
- 6 Guide tape mounting tool „FAV“ (optional)
- 7 Switch foil (for LIA 21)
- 8 Mounting screws (M3) for scanning head (for scanning heads with through holes only)

1

- Please mark the future location of the scale tape before starting with the mounting.
- The alignment of the scale tape depends on the installation position of the scanning head.
- Ensure that the scanning head's scanning fields for the counter and reference tracks are over the corresponding tracks on the scale tape.

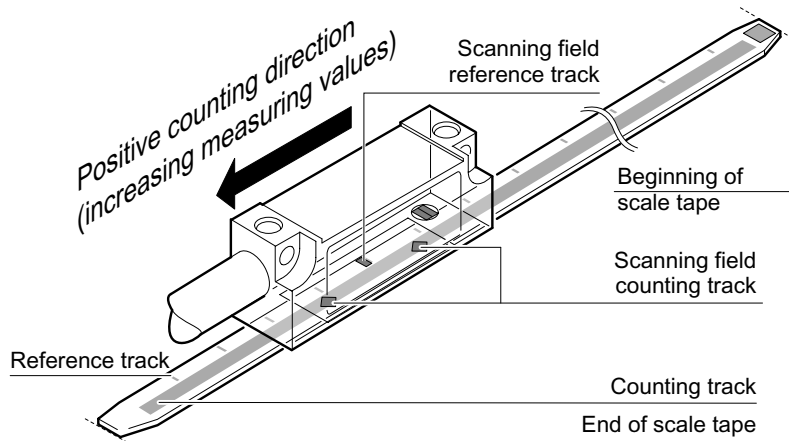

2

- Note the installation position of the guide tape applicator. The grating structure shown on the FAV must coincide with the grating structure of the steel tape.

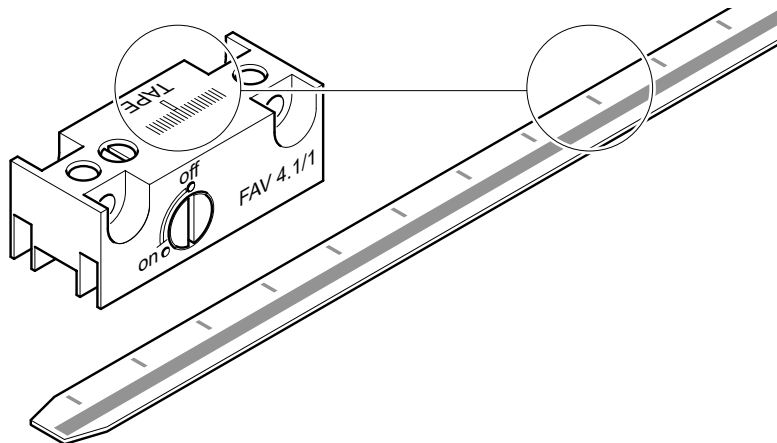

3

- Before mounting the FAV, turn the setting screws 1 and 2 to the „off“ position.:
 - 1. Turn the screw to the right until the slot points to „off“
 - 2. Turn the screw to the left until it is even with the surface of the FAV housing
- Use setting screw 1 for standard mounting.
- If the mounting conditions prevent access to setting screw 1, please use setting screw 2.

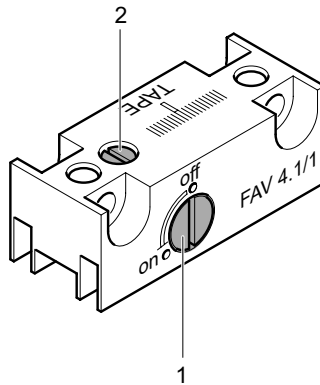

4

- Use a solvent to clean the adhesion surface of the machine (e.g. Acetone or Alcohol).
- Make sure that no alien elements are left on the machine's adhesion surface.
- ATTENTION: Acetone and Alcohol are inflammable liquids!

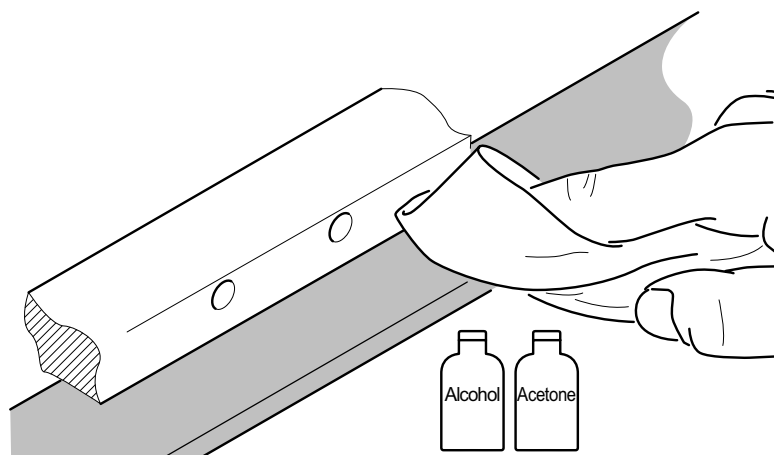

5

- Screw the FAV in place of the LIA scanning head in the appropriate location on the machine. Use the spacing gage „FAV“ to set a distance of 0.25 mm between the tape seating surface and the bottom of the FAV.

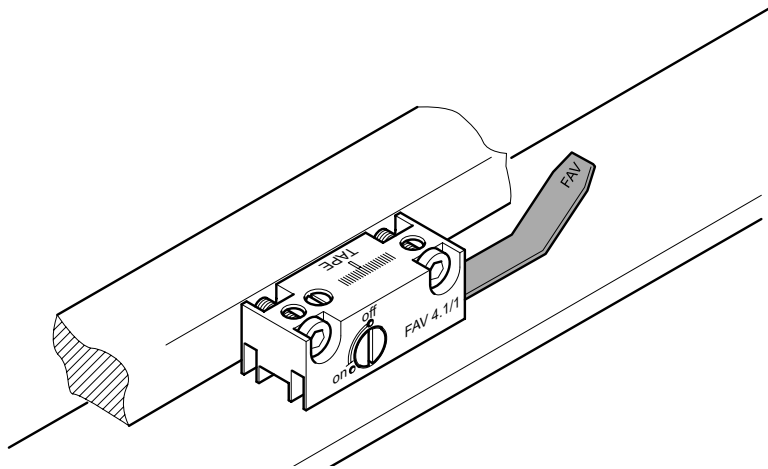

6

- Position the FAV ca. 150 mm to the right of the scale tape end by traversing the machine/encoder carriage.
- Slide the guide tapes from the right into the slots in the FAV, inserting them up to the end of the tape.
- Make sure that guide tapes with the correct thickness for the scale tape are used!
 - SINGLEFLEX scale tape: yellow protective film
 - DOUBLEFLEX scale tape: red protective film

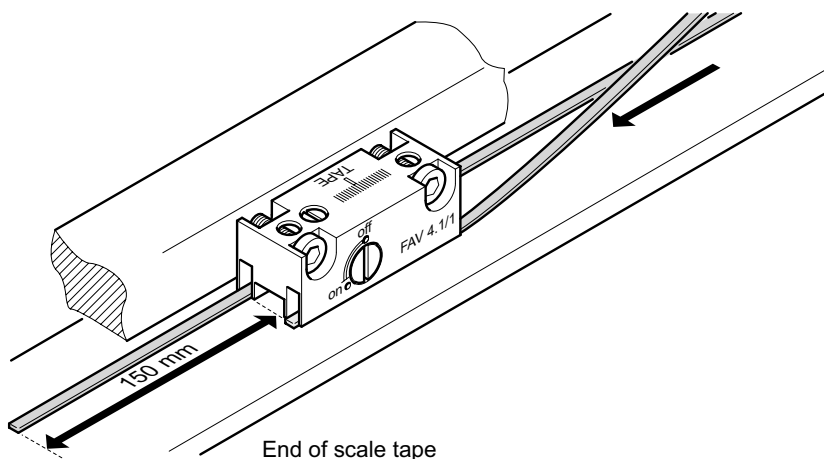

7

- Lift guide tape 1 cautiously.
- Pull off the protective film of the tape ca. 10 mm in the direction of guide tape 2.
- Replace guide tape 1 on the carrier.

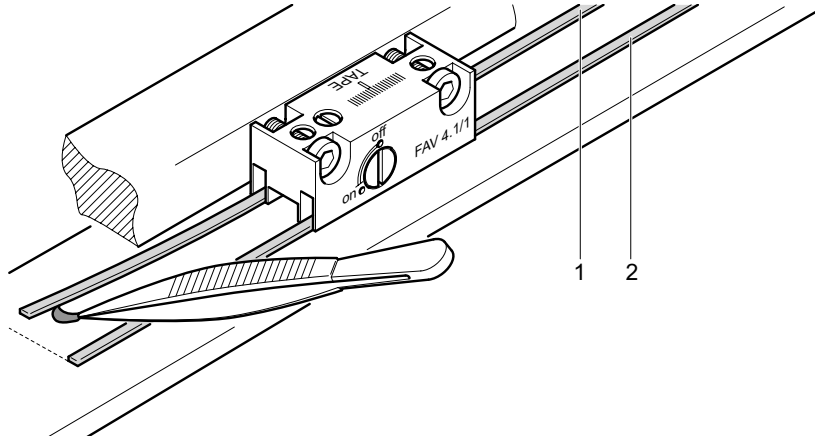

8

- Lift guide tape 2 cautiously.
- Pull off the protective film of tape 1 ca. 20 ... 30 mm beneath guide tape 2.
- Pull off the protective film of tape 2 ca. 10 ... 20 mm diagonally to the front.
- Replace guide tape 2 on the carrier.

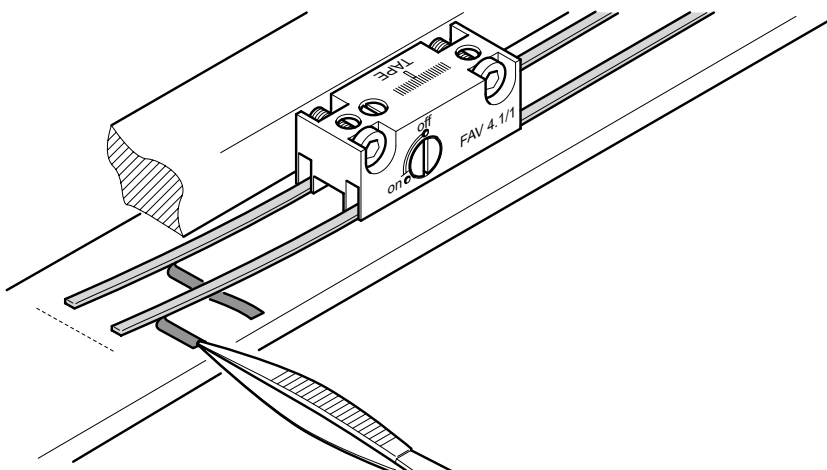

9

- Move the FAV to position 2, which is ca. 20 mm to the right of the scale tape end by traversing the machine/encoder carriage.
- Remove both protective films until the right edge of the FAV is reached.

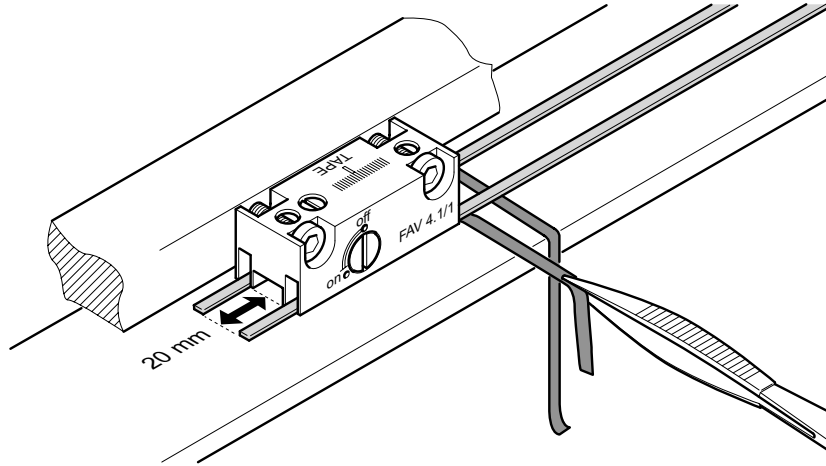

10

- Turn setting screw 1 to the left to the „on“ position, i.e. until the slot points to „on.“
- The guide tapes are now pressed against the carrier by the spring force.

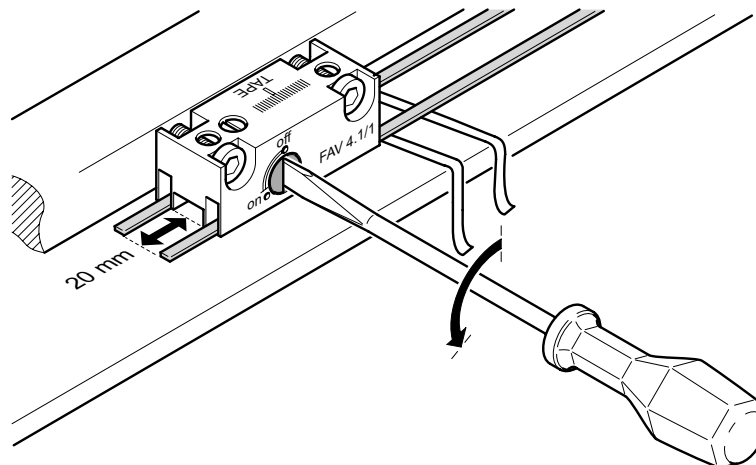

11

- Retract the FAV to right end of the scale tape with the carriage. Remove the protective films synchronously to the carriage/FAV motion in front of the FAV until they are completely removed.
- Return setting screw 1 to the „off“ position.
- Remove the FAV from the machine part.
- Press the right ends of the guide tapes against the carrier. Avoid any lateral offset of the tapes.

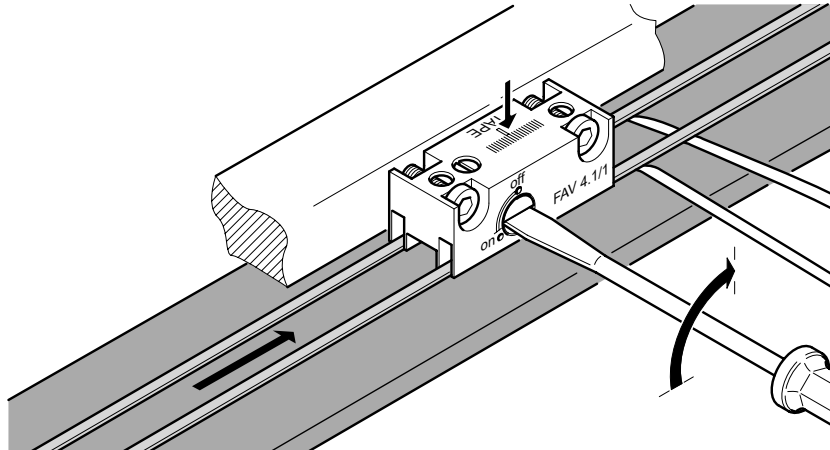

12

- The guide tapes are now aligned and attached parallel to the carriage motion, in the correct position relative to the scanning head windows, and at the correct distance from each other.
- The scale tape can now be mounted in the slot formed by the guide tapes.
- One of the guide tapes can be omitted if there is only limited mounting space.
- The scale tape can then be mounted along the edge formed by the guide tape.

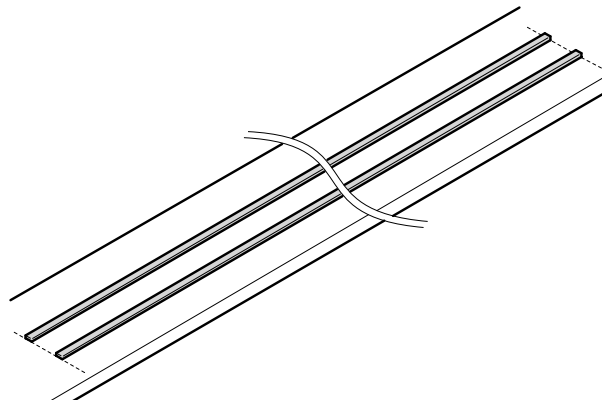

13

- Use a solvent to clean the adhesion surface of the machine (e.g. Acetone or Alcohol).
- Please check whether the guide tapes are firmly glued over the entire measuring length.
- Make sure that no contaminations remain on the machine's adhesion surface.
- Alien elements between the machine and scale tape cause local differences in the spacing between the scale tape and the scanning head. This may diminish the encoder's functionality and/or result in measuring errors.
- ATTENTION: Acetone and Alcohol are inflammable liquids!

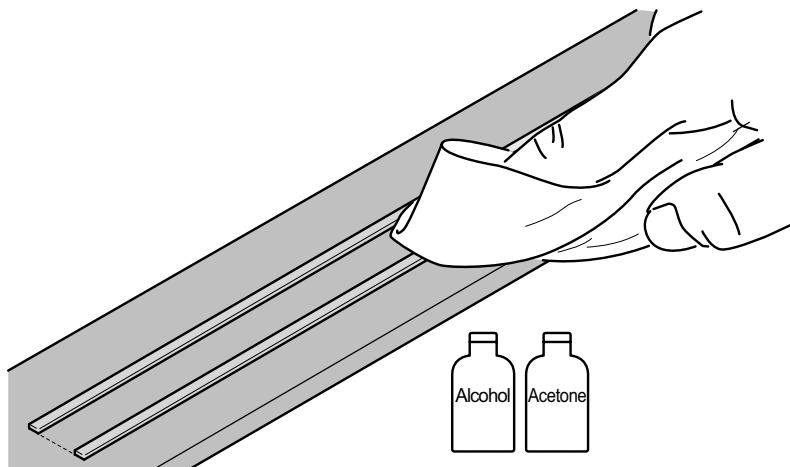

Information on installation of SINGLEFLEX and DOUBLEFLEX scale tapes



- The mounting steps of SINGLEFLEX and DOUBLEFLEX scale tapes are basically the same. But please pay attention to the following information on installation!
- The scale tape can be mounted in the slot or along the edge formed by the guide tapes, in a slot already on the machine or along an edge already on the machine.
- Place the edge of the scale tape exactly on the marking for the beginning of the scale tape.
- Run the scale tape exactly along the slot or edge when applying it.
- If DOUBLEFLEX scale tapes are mounted vertically, mount them so that the scale tapes lie adjacent to the stop edge (see also point 5.2).

14

- If you use a DOUBLEFLEX scale tape, glue the fixing point first.
- Please pay attention to the use and safety instructions from the manufacturer of the adhesive!
- Place a drop of adhesive on the center of the fixing point.
- Recommended adhesives:
 - Cyanoacrylate adhesives such as Loctite 480 or Loctite 401
 - Epoxy resin

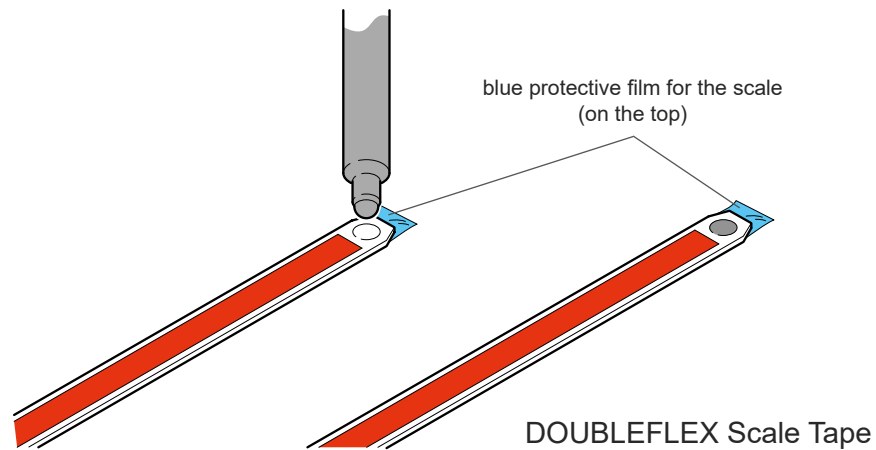

15

- Peel off ca. 70 mm of the red protective film on the back of the scale tape.
- The adhesive tape now exposed must not come into contact with other materials due to its strong adhesive force!
- Do not remove the blue transparent protective film from the scale tape yet!

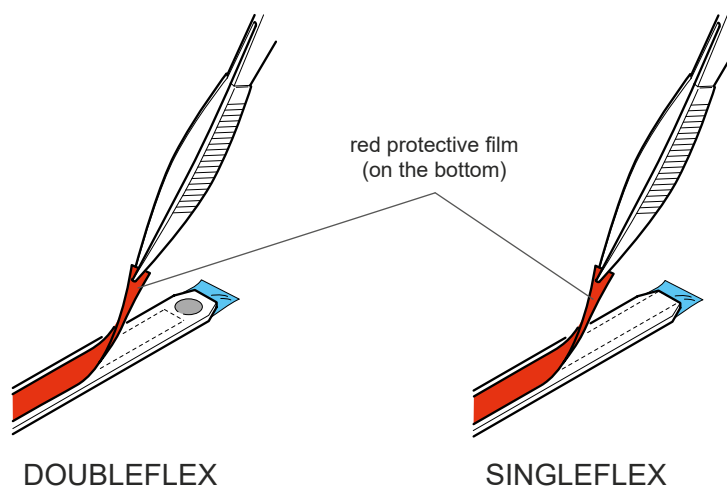

16

- When securing the scale tape, please pay attention to the alignment of the scanning head's windows for the counting and reference tracks!

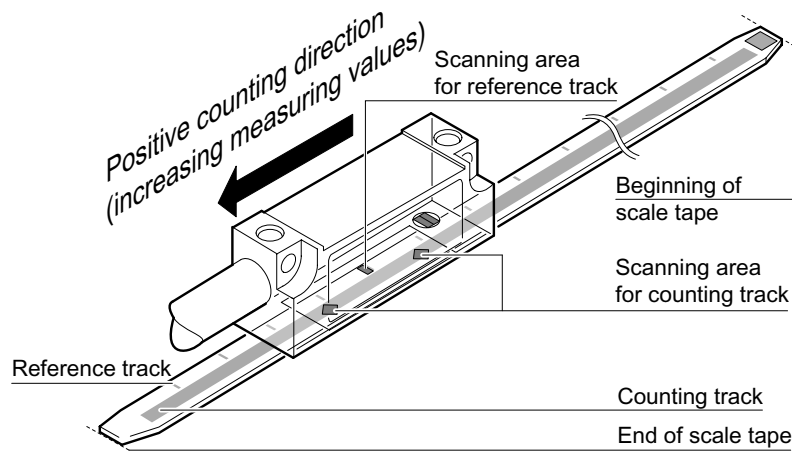

17

- Do not remove the blue transparent protective film from the scale tape yet!
- Remove the red protective film from the slot or edge.
- On the DOUBLEFLEX scale tape, apply the fix point with the drop of adhesive (at either the beginning or end of the scale tape) and at the same time secure the first ca. 50 mm of the scale tape.
- Place the end of the SINGLEFLEX scale tape from which the protective film has been removed against the front end stop (slot) or lateral stop (edge).

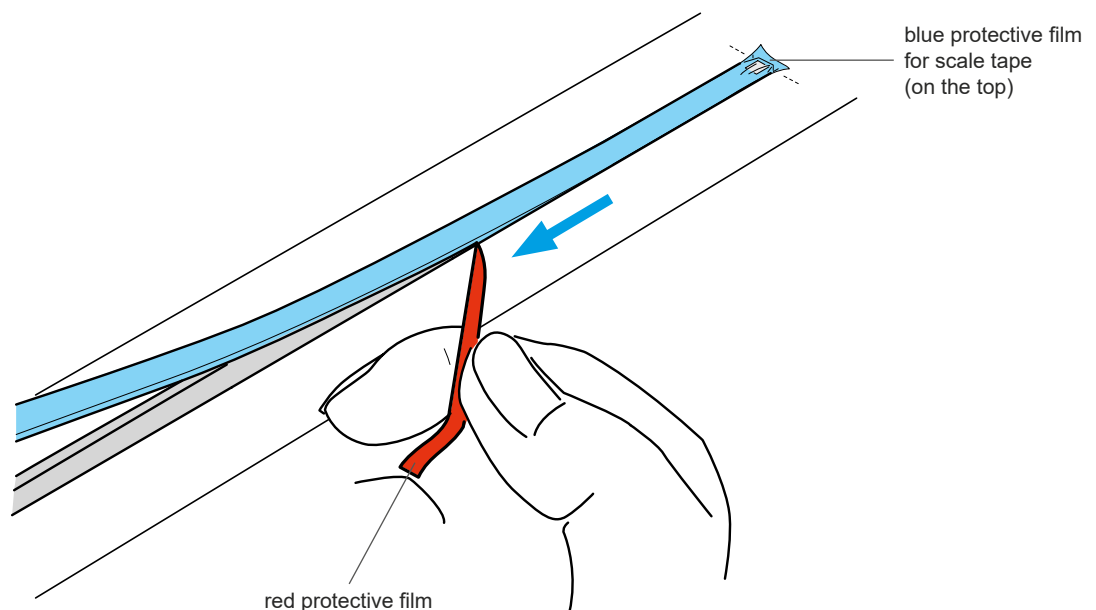

18

- Do not remove the blue transparent protective film from the scale tape yet!
- Press the scale tape with your forefinger and by the help of a soft, lint-free rag against the carrier over the entire length. Pull off the red protective film to the side. The pressure point should always be ca. 30 mm to 50 mm behind the point where the adhesive tape and the red protective film are being separated.
- **Only apply pressure to the scale tape from above and avoid lateral forces!**

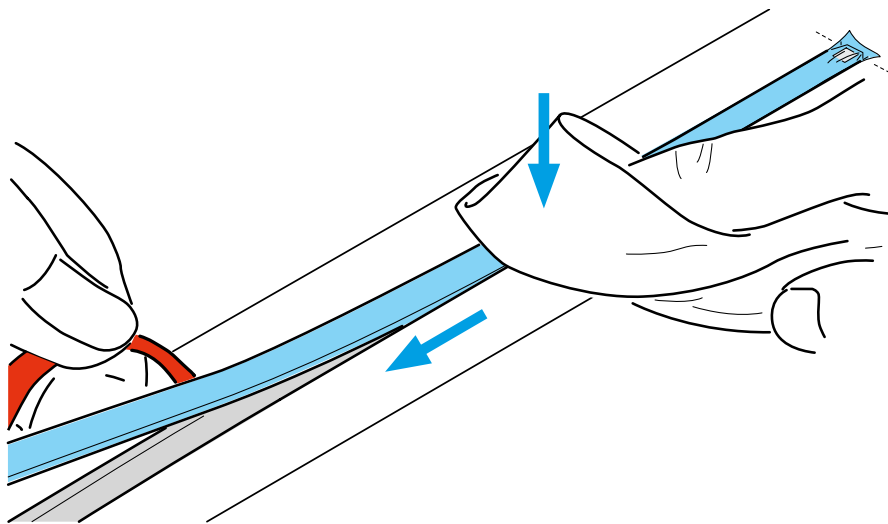

19

- Clean the mounting surfaces of the scanning head and the machine element.
- Remove the protective film from the scanning head.
- Clean the sensor surface of the scanning head with a soft and lint-free rag. Use a solvent if necessary (e.g. Acetone or Alcohol).
- **ATTENTION: Acetone and Alcohol are inflammable liquids!**

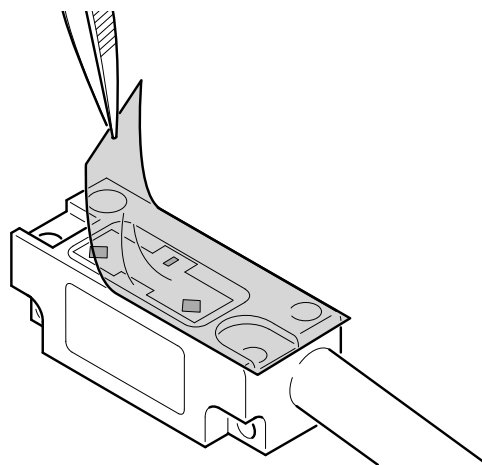

20

- Screw the scanning head onto the prepared mounting surface such that there is still some vertical clearance.
- Remove the blue transparent protective film (in case of DOUBLEFLEX scale tape, always begin at the fixing point) from the graduation of the scale tape.
- Clean the scale tape surface (graduation) of the scanning head with a soft and lint-free rag. Use a solvent if necessary (e.g. Acetone or Alcohol).
- ATTENTION: Acetone and Alcohol are inflammable liquids!

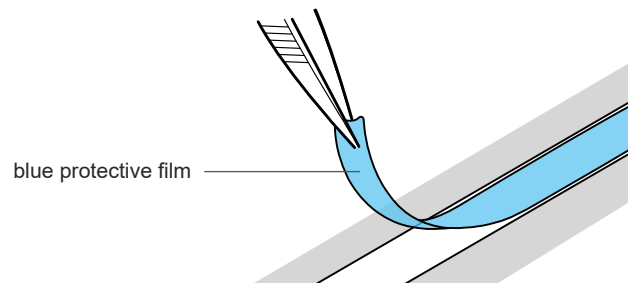
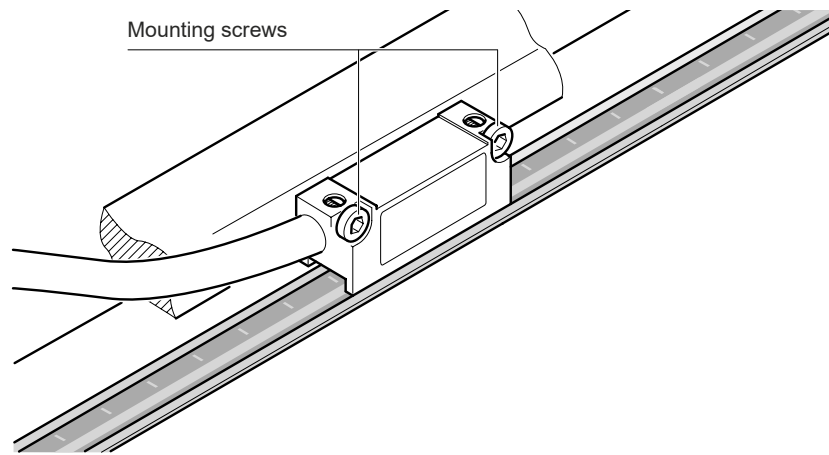

21

- Insert the spacing gage “0,6” lengthwise between the scale tape surface and the scanning head.
- Push the scanning head against the spacing gage and tighten the two mounting screws alternately and evenly (tightening torque = 1 Nm). The spacing gage should barely be movable.
- Check the parallelism of the scanning head to the scale tape. Push the spacing gage ca. 5 mm to the left and right between the scanning head and scale tape, checking whether the clearance is the same.
- Remove the spacing gage cautiously. If it is difficult to remove the spacing gage, loosen the scanning head and repeat the mounting procedure. Otherwise the surface of the sensor module can be damaged!

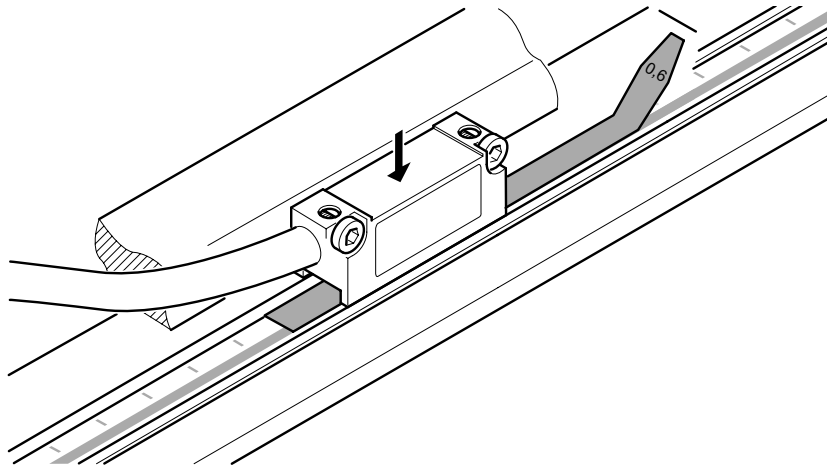

22

- Position the encoder cable including the strain relief near the scanning head.
- Connect the encoder cable to the evaluation electronics and pay attention to the pin assignment. The evaluation electronics must be switched off!
- After connecting the encoder cable switch the evaluation electronics on and test the functionality.
- If there are errors in the function or during measurement, please read chapter 10 “Troubleshooting” first. If these information are not helpful for your problem, please contact the technical support of NUMERIK JENA or an authorized representation in your country.

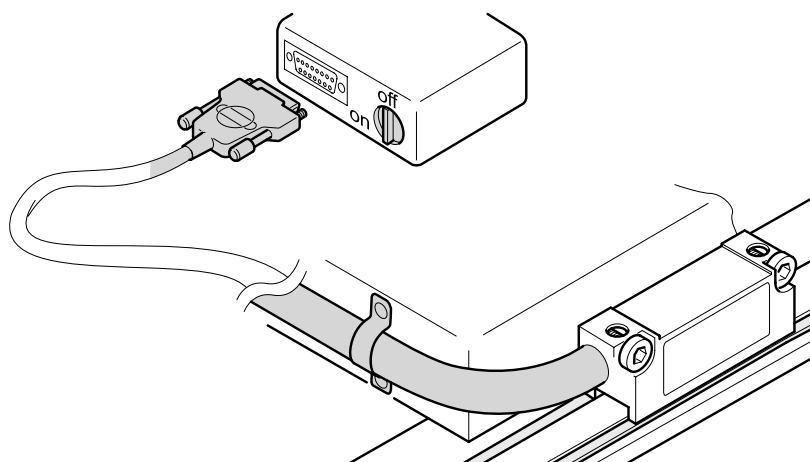

Information on signal adjustment after mounting

- The measuring systems from NUMERIK JENA provide the possibility to adjust the signals electronically after mounting. This is useful for signal optimization regarding to the individual mounting conditions. This minimizes short-wave position errors (interpolation errors), positively affecting the operational behavior of the encoder.
- For further information about the signal adjustment and the necessary accessory “ADJUSTMENT TOOL”, see chapter 8.

23

- Please clean the adhesion surface with solvent (e.g. Acetone or Alcohol) before applying the switch foil or reflecting foil.
- Apply the standard self-adhesive switch foil to the guide tape appropriately for the desired position for the switching point and for the desired position accuracy (see also point 6.3, 7.3 and 7.4).
- ATTENTION: Acetone and Alcohol are inflammable liquids!

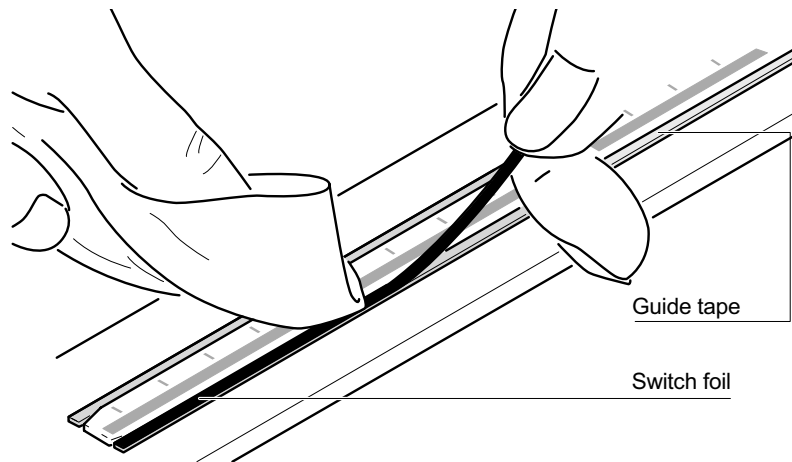

24

- If no guide tapes are used, first apply the reflecting foil as the carrier for the switch foil over the entire measuring length to the slot or edge of the scale-tape carrier (machine/device).
- Apply the switch foil appropriately for the desired position for the switching point and for the desired position accuracy to the reflecting foil (see also point 6.3, 7.3 and 7.4).
- The surfaces of the scale tape and the switch foil must be in the same level (tolerance: ± 0.1 mm).

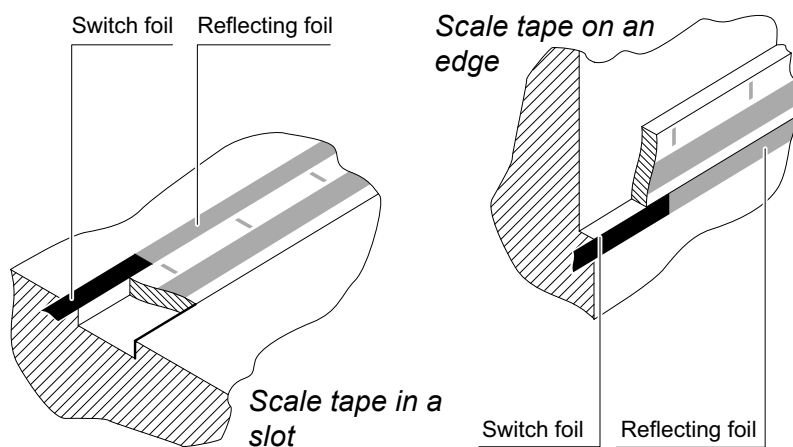

5.6 Specifying the Switch Point of the Switch Sensor for LIA 21

- Mount the switch foil with an overlength of at least 4 mm (see also point 6.3, 7.3 and 7.4).
- Connect the scanning head to the evaluation electronics (e.g. controller or display).
- Reset the counter at the reference point for the switch signals.
- Move the nominal distance Z1 / Z2 between the reference point (either a reference mark or the start of the measuring length) and the switch point.
- Depending on the direction of the traverse, add or subtract the distance A between the edge of the scanning head and the switch sensor to/from the nominal distance (Distance A for switch sensor S1 = ± 3 mm).
- Cut the switch foil with a sharp blade at the desired switch edge and remove the extra piece.

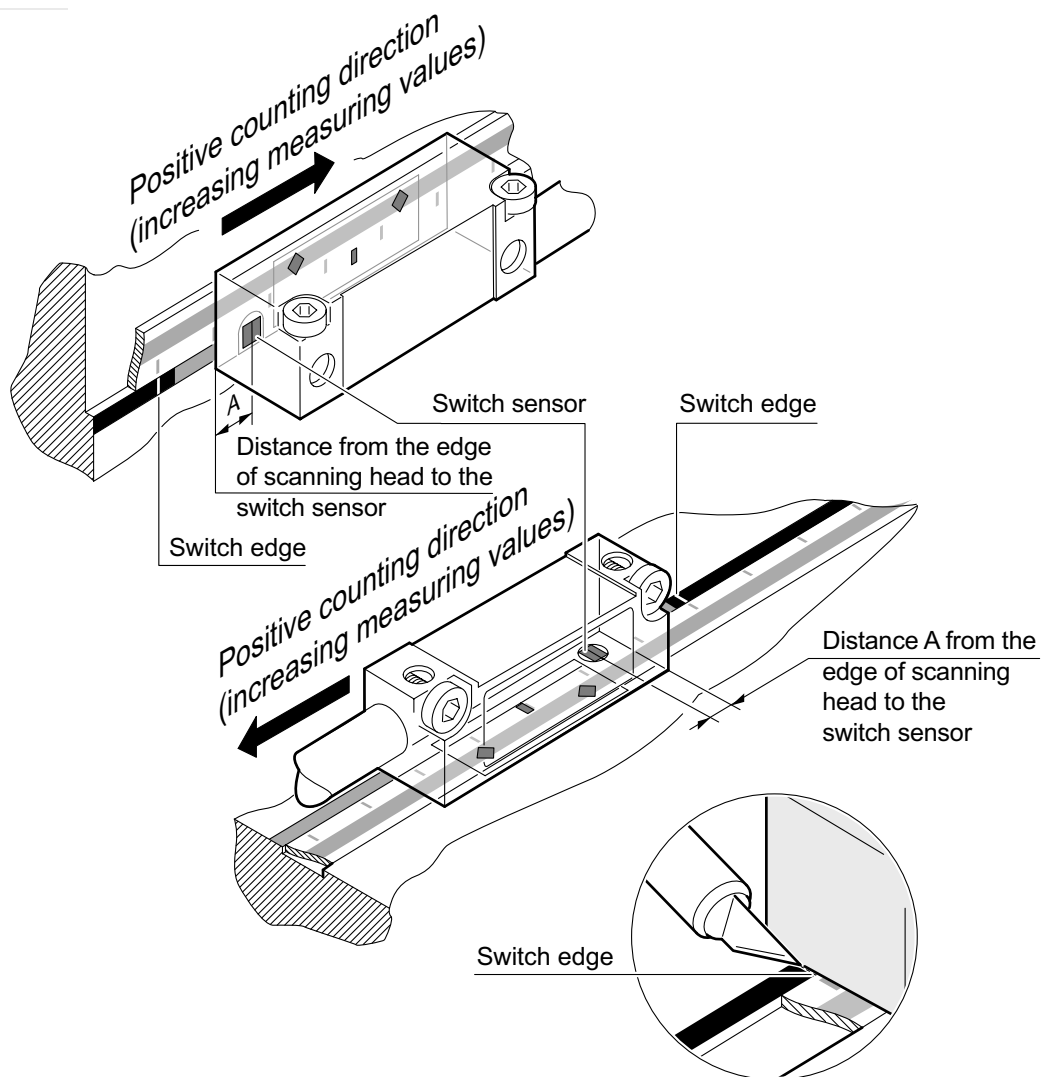

Detail at edge and slot with reference mark as reference point

6. Mounting Drawing - LIA 20 / 21

6.1 Scanning Head LIA 20 / 21

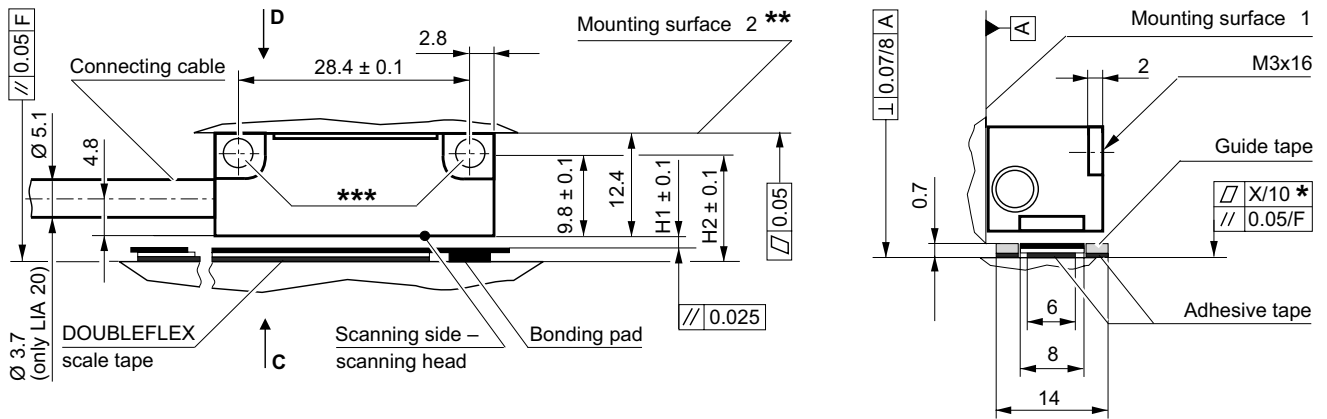
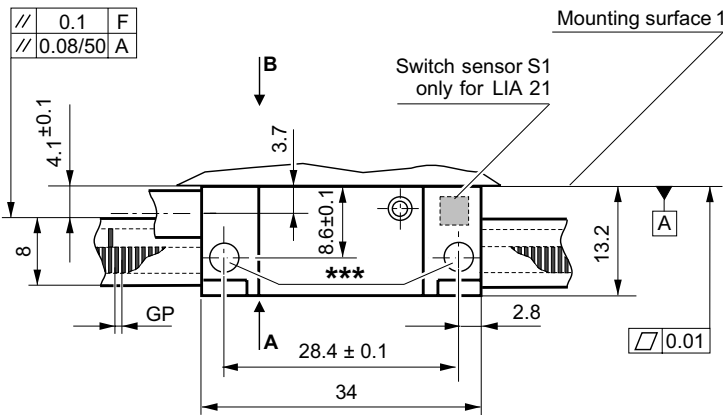

Illustration with DOUBLEFLEX scale tape



Accuracy class	X
±1 µm	0.003
±2 µm	0.006
±3 µm	0.009
±5 µm	0.009

*	Deviation X per 10 mm of scale tape length
**	The mounting surface 2 must be vertically adjustable to ensure that the distance parameter H1 ±0.1 and the parallelism 0.025 can be achieved
***	Ø 3.6 for M3 screws from side A or C, M4-6H for screws from side B or D

Grating period (TP)	H1		H2	
	SINGLEFLEX scale tape	DOUBLEFLEX scale tape	SINGLEFLEX scale tape	DOUBLEFLEX scale tape
20 µm	0.6 mm	0.6 mm	10.9 mm	11.1 mm
100 µm	1.3 mm	1.3 mm	11.6 mm	11.8 mm

6.2 Assignment of Scanning Head, Scale Tape and Measuring Length

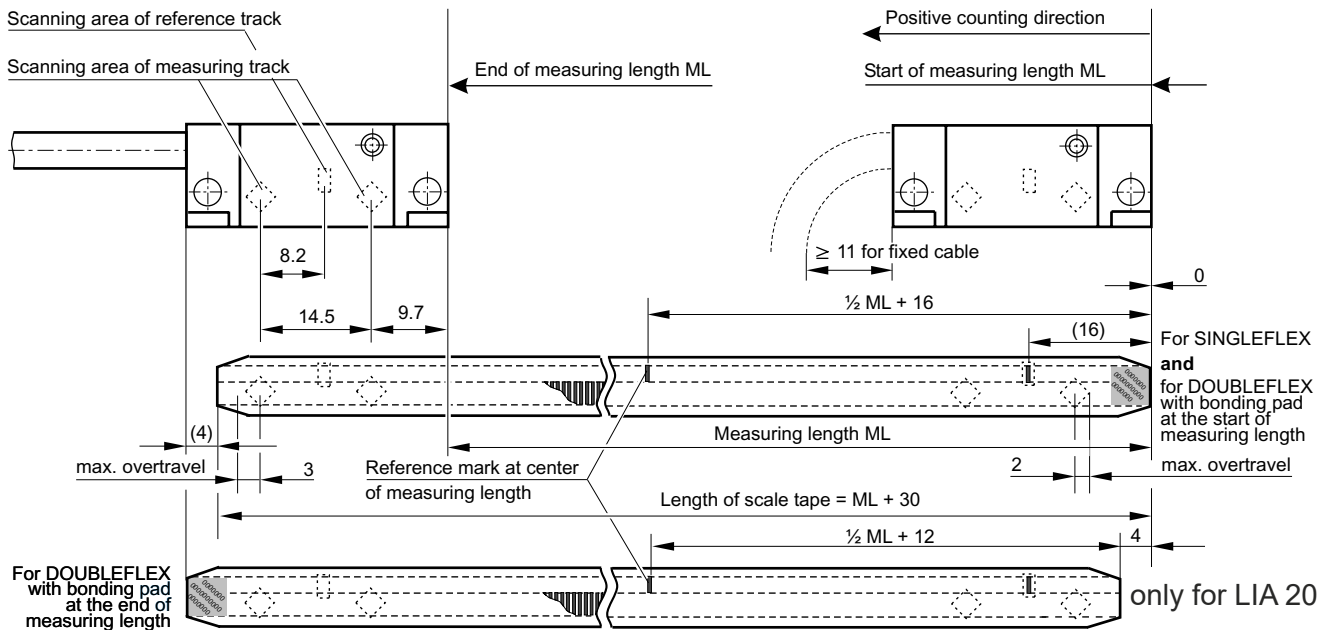

Scanning head shown with lateral offset to the scale tape, seen from above through the scanning head to the scale tape

6.3 Using of Switch Sensor and Switch Foil (LIA 21)

Indication of the End Position(s)

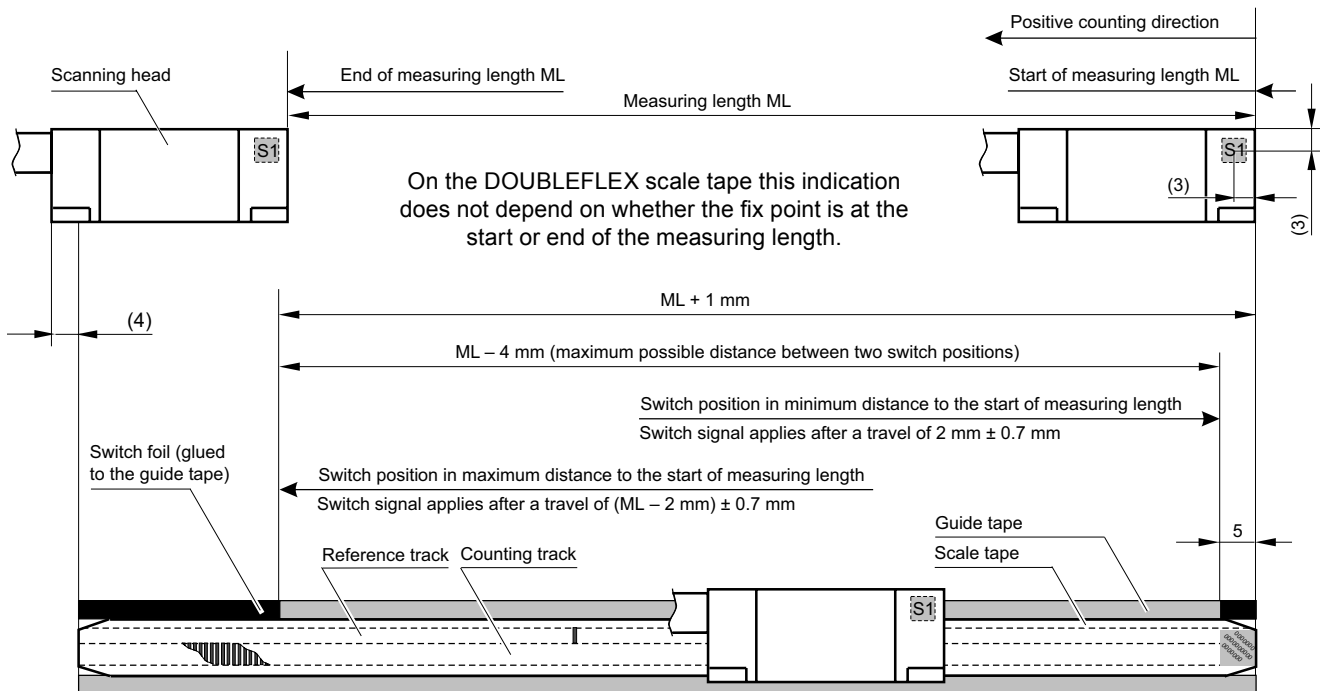

Indication of the Scanning Head Position within the Measuring Range

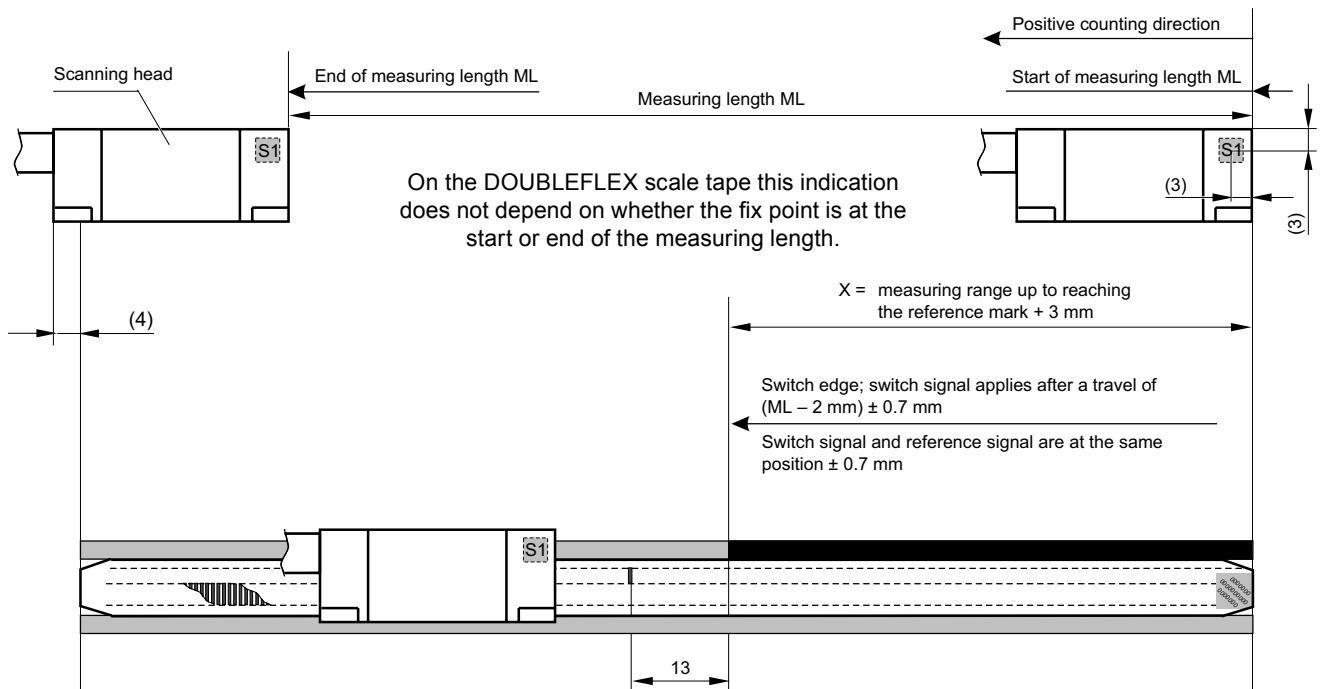

Enabling of the Reference Signal, i.e. Selection of one Reference Mark from n Reference Marks

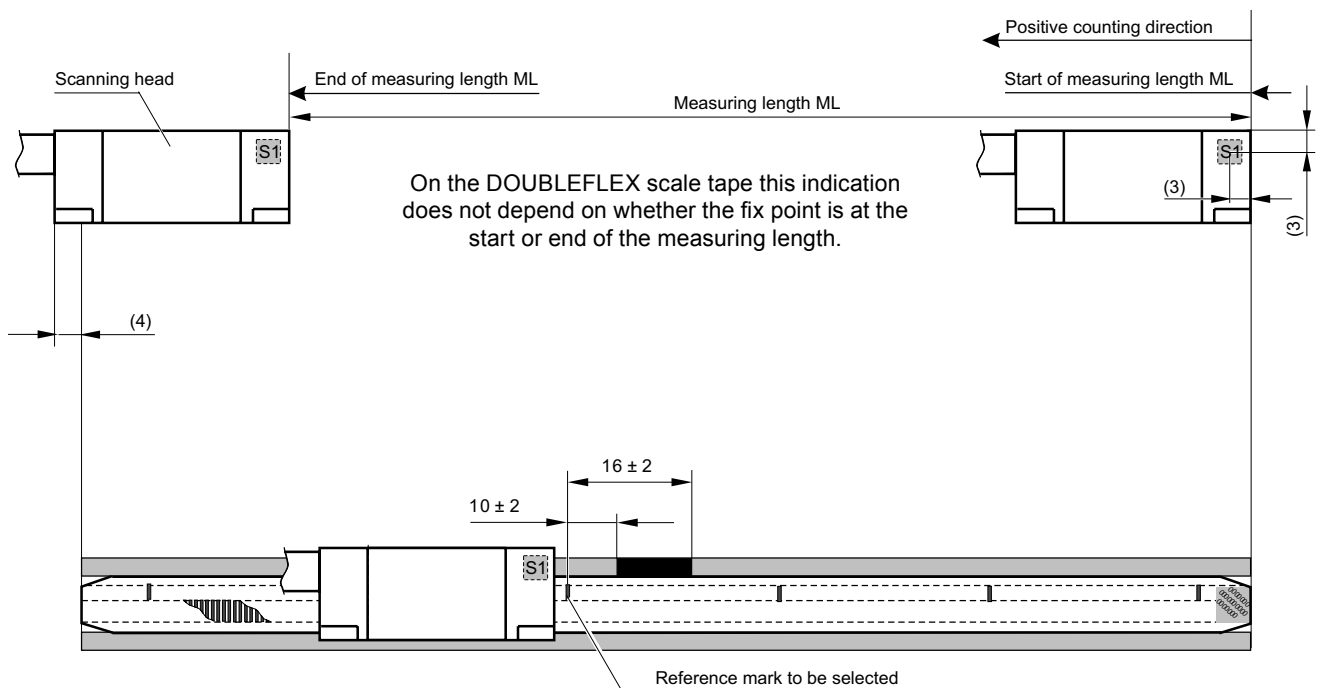

Specification of the Switch Point / Edge to the Reference Point: Reference Mark

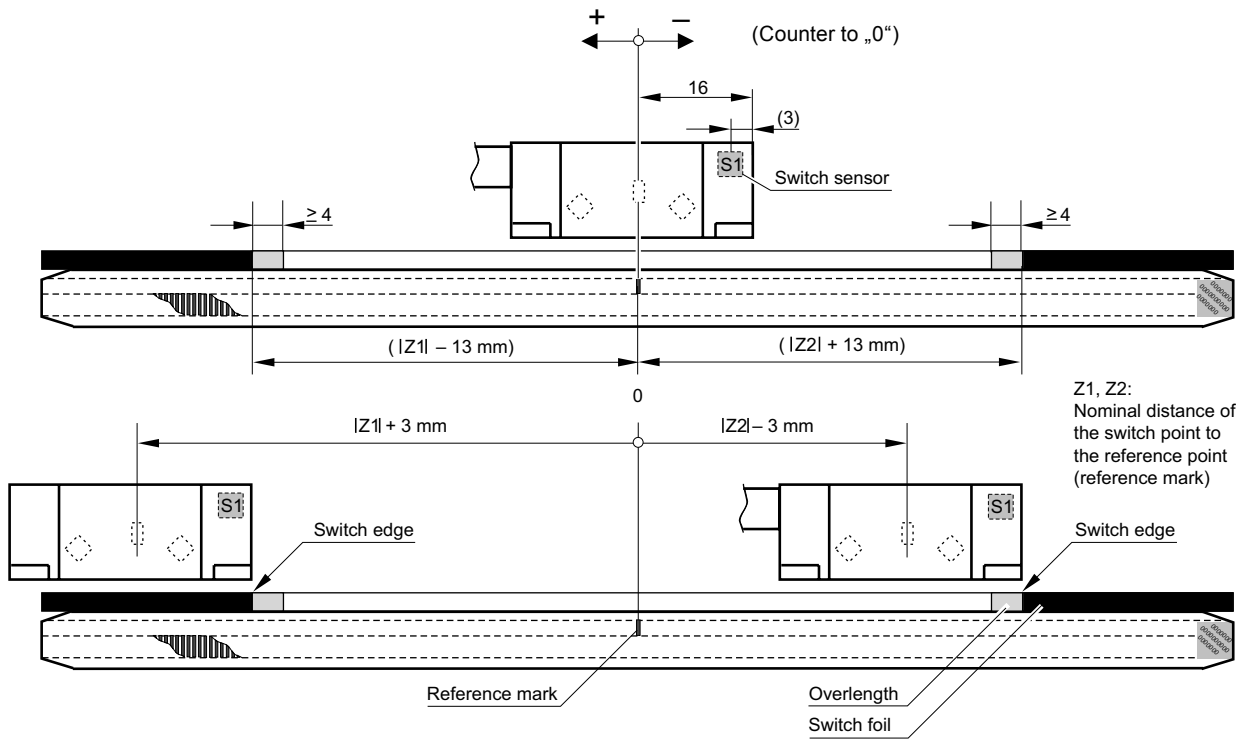

Specification of the Switch Point / Edge to the Reference Point: Start of Measuring Length

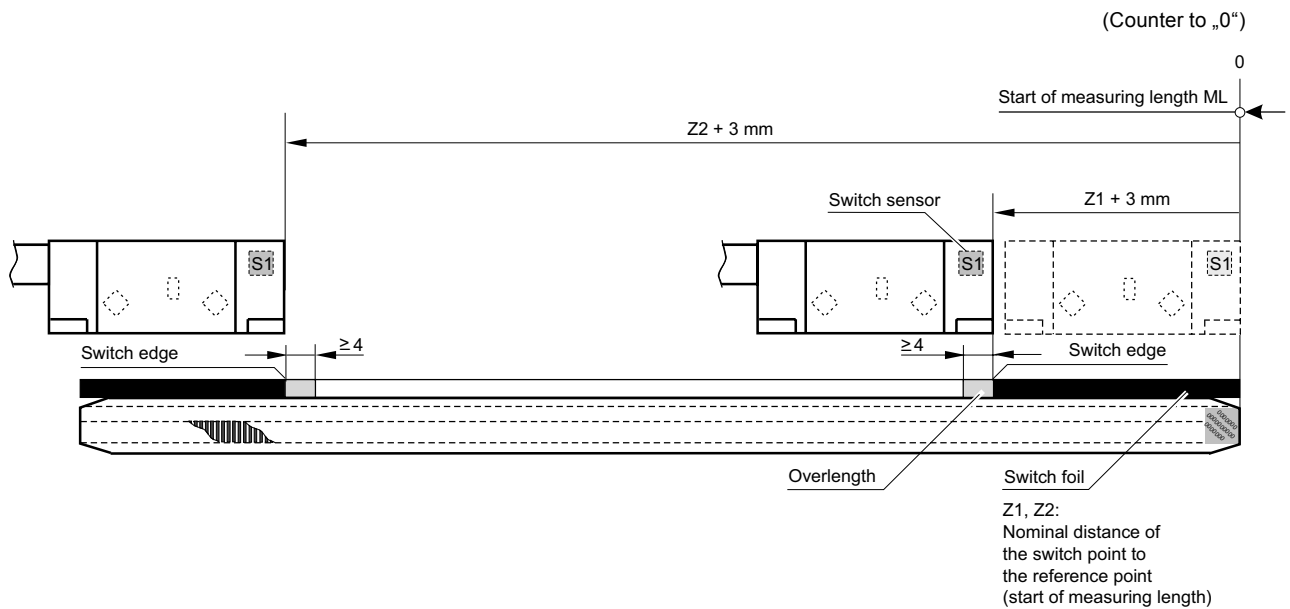

6.4 Permissible Mounting Tolerances and Position Deviations (Coordinates)

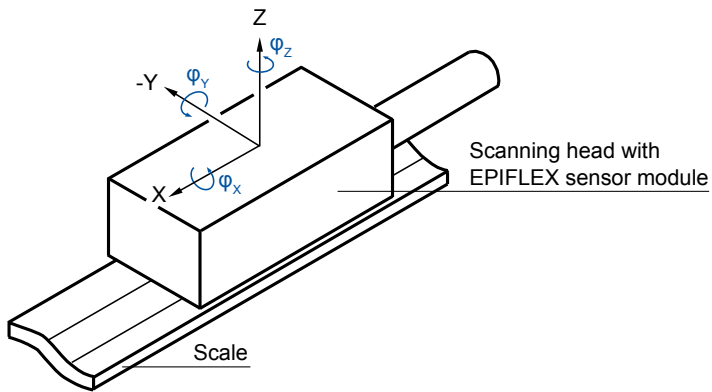

$$\begin{aligned}\Delta Z &= \pm 0.1 \text{ mm} \\ \Delta Y &= \pm 0.3 \text{ mm} \\ \varphi Z &= \pm 0.15^\circ (\pm 9') \\ \varphi Y &= \pm 0.25^\circ (\pm 15') \\ \varphi X &= \pm 2.0^\circ (\pm 120')\end{aligned}$$

Gap between sensor and scale = 0.6 mm
(for 20 μm grating pitch)

These cumulative tolerances include mounting tolerances and guideway error during operation.

7. Signal Adjustment with ADJUSTMENT TOOL

Before delivery the encoders from NUMERIK JENA will be tested and electronically adjusted under ideal mounting conditions. Furthermore, the sensor modules offer the possibility of an electronic signal adjustment after the mounting into the application. This allows the user optimize the encoder signals regarding to the mechanical mounting conditions (tolerances).

The ADJUSTMENT TOOL and the related EPIFLEX software was designed to simplify and make the signal adjustment more effective.

7.1 Functions of the ADJUSTMENT TOOL

- Representation of the sinusoidal counting signals with amplitude, offset and phase position
- Representation of the position and width of the index signal
- Evaluation of the mechanical mounting conditions
- Automatic signal adjustment and programming of the sensor module
- Electronic readjustment of the amplitude and offset of the sensor signals
- Adjustment of the position and width of the index signal

7.2 Dynamic Offset and Amplitude Control (Online Compensation)

The encoders of NUMERIK JENA are equipped with a dynamic amplitude and offset control (online compensation). The analog diode signals will be corrected to their nominal values in real time. This reduces measuring errors caused by contamination of the scale tape as well as from inaccuracies in the guide way. The phase position between the sine and cosine signals and the position of the index signal are not influenced by the online compensation.

With help of the EPIFLEX Software the preadjusted nominal values of the online compensation can be influenced.

7.3 Scope of Delivery

- ADJUSTMENT TOOL black box
- Diagnostic cable to connect the measuring system
- USB cable to connect a PC
- USB - D-SUB - adapter cable (15-pin)
- Exchangeable 8-pin plug connectors



Image 20

7.4 EPIFLEX Software

The EPIFLEX software was especially designed for the ADJUSTMENT TOOL. It offers the user versatile possibilities to bring the encoder into service. It also allows the user to display the sensor signals and evaluate them without using an oscilloscope or other expensive hardware. Furthermore it is possible to program respectively optimize the encoder to the existing mounting conditions automatically.

The EPIFLEX software is available for free via download on the NUMERIK JENA website under www.numerikjena.de. Furthermore, one can order the software with an optional USB flash drive.

The EPIFLEX software is suitable for the following operating systems:

- Windows 7 / 8 (32 or 64 bit)

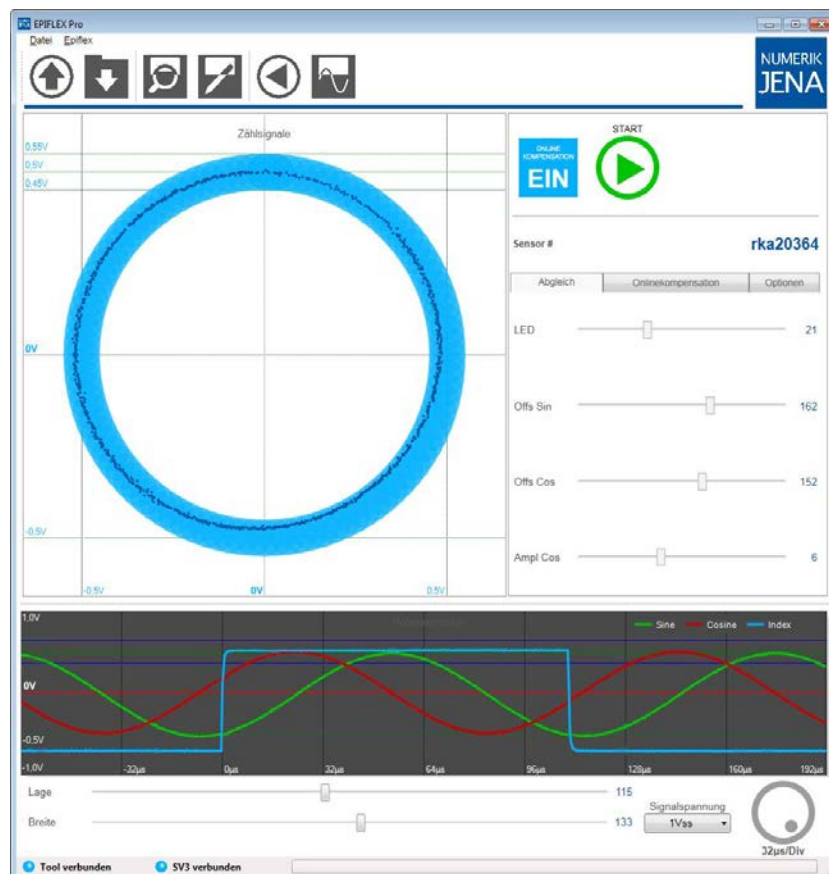

Image 21

Further information about the ADJUSTMENT TOOL and the EPIFLEX software can be found on the NUMERIK JENA website.

8. Cleaning



8.1 Measuring System

- Depending on the measuring system's mounting attitude and the ambient conditions, it may be necessary to clean the scale tape surface and sensor surface of the scanning head (scanning window for counting and reference track) occasionally.
- If the monitoring signal output by the scanning head is used, the encoder indicates that cleaning is necessary.
- When cleaning the components, ensure that the scanning window and scale tape are not scratched by any deposited particles!
- Dirt should be removed using a soft brush or oil-free compressed air.
- Use cotton balls or a soft and lint-free rag for cleaning. Use a solvent if necessary (e.g. Acetone or Alcohol).
- ATTENTION: Acetone and Alcohol are inflammable liquids!

8.2 Scale Tape

- Avoid to contact the solvent and the adhesive tape! This could start to dissolve the adhesive and reducing the adhesive force. Furthermore the scale tape can be detached totally.
- Please always wipe the DOUBLEFLEX scale tape lengthwise. Wiping it crosswise could result in an offset of the scale tape relative to the carrier tape and leading to errors in the function of the measuring system.
- Ensure that no solvent seeps under the scale tape! This could adversely affect the adhesive layer between the scale tape and carrier tape, thereby loosening the scale tape.

9. Troubleshooting

The functions of all scanning heads and accuracy of all scale tapes are tested before the encoders are shipped. However, if troubles or problems should occur, please read the following points in the chart and proceed according to this information.

If this is not helpful, please contact the technical support of NUMERIK JENA GmbH or one of our authorized subsidiaries. You will find respective contact data on the NUMERIK JENA website www.numerikjena.de.

Error	Possible causes	Solution
No measuring signal	No power at the scanning head	<ul style="list-style-type: none"> • Check the status of the evaluation electronics • Check the connection assignment between the encoder and the evaluation electronics
Error message from the evaluation electronics	Following error due to temporary failure of the measuring signal	<ul style="list-style-type: none"> • Check the assignment of the scale tape to the scanning head • p.r.n. readjust mechanically • Readjust electronically with ADJUSTMENT TOOL*
Rough, loud motor running (for linear motors)	Irregular edge separations of the counting signals due to interpolation errors	
Counting error (compared to a standard)	Mounting error	
No reference signal	Mounting error (results in faulty gating of the reference signal and counting signal)	
Reference mark can only be detected from one direction		
Reference mark appears twice		
Not all reference marks are detected	Mounting error (results in level of the analog signal from the sensor being too low)	Clean the scale tape
Failure signal reports (for RS 422)		
		Encoder function operating error

Tabelle 8

* see also chapter 7

Error	Possible causes	Solution
Switch signal does not function	Scanning gap incorrect	Compare the gap between the switch sensor and reflective surface in the mounting drawing, adjust if necessary
	Reflective capacity of the switch-foil carrier insufficient (e.g. if no guide tapes are used for applying the switch foils)	Use reflecting foil from NUMERIK JENA
	Control requests a different type of switch sensor	Check the type of switch sensor

Tabelle 9



Image 22

10. Ordering Key

10.1 Scanning Head

Ordering key - example

LIA 2 1 - P 4 1 2 - F Z

Number of switch sensors

0	w/o switch sensor
1	1 switch sensor

Grating period (TP)

-	20 μm
---	------------------

Interface

C	1 V _{pp} sinus signal
K	RS 422 square-wave signal w/o interpolation
L	RS 422 square-wave signal with interpolation 5-times
M	RS 422 square-wave signal with interpolation 10-times
I	RS 422 square-wave signal with interpolation 25-times
N	RS 422 square-wave signal with interpolation 50-times
P	RS 422 square-wave signal with interpolation 100-times

Speed factor

X	Customer-specific value, depending on the traversing speed and the counting frequency of the evaluation electronics (see page 64 et seq.)
---	---

Interface - Switch sensors

0	w/o sensor (LIA 20)
1	one sensor - TTL - low active
5	one sensor - TTL - high active
A	one sensor - open collector - low active
D	one sensor - open collector - high active
G	one sensor - MOS-relay - N/C contact
H	one sensor - MOS-relay - N/O contact

Housing - Version

1	Scanning head with through holes \varnothing 3.6 mm
2	Scanning head with thread M4

Type of connector

A	10 pin JST mini. connector, female ^{1,6}
D	9 pin D-Sub, male ^{1,4}
H	12 pin round connector, male ¹
O	15 pin D-Sub, male ^{1,4}
Z	15 pin D-Sub, male (electronics in the connector) ^{4,5}
S	Special connector (on request) ¹

Cable - LIA 20 (\varnothing 3.7 mm)single-shielded²

R	0.3 m
S	0.5 m
T	1.0 m
P	1.5 m
V	2.0 m
W	3.0 m
U ¹	further lengths on request (max. 3.0 m)

Cable - LIA 20 / 21 (\varnothing 5.1 mm)double-shielded³

A	0.3 m
B	0.5 m
F	1.0 m
E	1.5 m
G	2.0 m
K	3.0 m
O	further lengths on request (max. 3.0 m)

Version

-	standard
3	non-magnetic scanning head

¹ Only for LIA 20² Only for LIA 20 with interpolation electronics in scan. head³ For LIA 20 / 21 with interpolation electronics in the D-Sub connector⁴ Straight cable outlet⁵ Interpolation electronics in the D-Sub connector (standard for LIA 21)⁶ 10 pin JST min. connector can be removed (for open cable end)

10.2 Speed Chart for LIA Series

10.2.1 LIA Series with Op-Amp

The maximum attainable traversing speed of the encoder is determined by the maximum output frequency of the interpolator and/or the maximum counting frequency of the operator's evaluation electronics (e.g. controller or display).

Please take the suitable values for your application from the following charts and enter it into the corresponding place (for "X") in the ordering key. Pay attention to your chosen interpolation factor and the targeted traversing speed first. If you have found the respective information, please check if your evaluation electronics is able to achieve the needed counting frequency.

The maximum scanning frequency of the encoder amounts to 200 kHz standardly, hence the maximum attainable traversing speed will be derived from that. The op-amp decouples parasitic frequencies and improves the interference immunity of the encoder under unfavorable conditions. The encoders from NUMERIK JENA are available without op-amp also. Thus it is possible to increase the scanning frequency which consequently enables higher traversing speeds up to 10 m/s.

C Without interpolation factor

Value for X	Max. traversing speed (in m/s)	Max. scanning frequency of the measuring system (in kHz)	Min. counting frequency of the evaluation electronics without 4-edge evaluation (in MHz)	Min. counting frequency of the evaluation electronics with 4-edge evaluation (in MHz)
0	4.00	200	0.75	3

L Interpolation factor = 5

Value for X	Max. traversing speed (in m/s)	Max. scanning frequency of the measuring system (in kHz)	Min. counting frequency of the evaluation electronics without 4-edge evaluation (in MHz)	Min. counting frequency of the evaluation electronics with 4-edge evaluation (in MHz)
1	0.67	33	0.25	1
2	1.33	67	0.50	2
Y	2.00	100	0.75	3
3	2.67	133	1.00	4
Z	4.00	200	1.50	6

M Interpolation factor = 10

Value for X	Max. traversing speed (in m/s)	Max. scanning frequency of the measuring system (in kHz)	Min. counting frequency of the evaluation electronics without 4-edge evaluation (in MHz)	Min. counting frequency of the evaluation electronics with 4-edge evaluation (in MHz)
1	0.33	17	0.25	1
2	0.67	33	0.50	2
Y	1.00	50	0.75	3
3	1.33	67	1.00	4
Z	2.00	100	1.50	6
4	2.67	133	2.00	8
5	4.00	200	3.00	12

The listed values in the charts refer to a grating period (TP) of 20 µm.

I Interpolation factor = 25

Value for X	Max. traversing speed (in m/s)	Max. scanning frequency of the measuring system (in kHz)	Min. counting frequency of the evaluation electronics without 4-edge evaluation (in MHz)	Min. counting frequency of the evaluation electronics with 4-edge evaluation (in MHz)
1	0.13	7	0.25	1
2	0.27	13	0.50	2
Y	0.40	20	0.75	3
3	0.53	27	1.00	4
Z	0.80	40	1.50	6
4	1.07	53	2.00	8
5	1.60	80	3.00	12
6	2.13	107	4.00	16
7	2.67	133	5.00	20
8	3.20	160	6.00	24

N Interpolation factor = 50

Value for X	Max. traversing speed (in m/s)	Max. scanning frequency of the measuring system (in kHz)	Min. counting frequency of the evaluation electronics without 4-edge evaluation (in MHz)	Min. counting frequency of the evaluation electronics with 4-edge evaluation (in MHz)
1	0.07	3	0.25	1
2	0.13	7	0.50	2
Y	0.20	10	0.75	3
3	0.27	13	1.00	4
Z	0.40	20	1.50	6
4	0.53	27	2.00	8
5	0.80	40	3.00	12
6	1.07	53	4.00	16
7	1.33	67	5.00	20
8	1.60	80	6.00	24

P Interpolation factor = 100

Value for X	Max. traversing speed (in m/s)	Max. scanning frequency of the measuring system (in kHz)	Min. counting frequency of the evaluation electronics without 4-edge evaluation (in MHz)	Min. counting frequency of the evaluation electronics with 4-edge evaluation (in MHz)
1	0.03	2	0.25	1
2	0.07	3	0.50	2
Y	0.10	5	0.75	3
3	0.13	7	1.00	4
Z	0.20	10	1.50	6
4	0.27	13	2.00	8
5	0.40	20	3.00	12
6	0.53	27	4.00	16
7	0.67	33	5.00	20
8	0.80	40	6.00	24

The listed values in the charts refer to a grating period (TP) of 20 µm.

10.2.2 LIA Series without Op-Amp

The maximum scanning frequency of the encoder without op-amp amounts to 500 kHz, hence the maximum attainable traversing speed will be derived from that. This enables traversing speeds up to 10 m/s.

C (1 VSS) or K (RS 422) Without interpolation factor

Value for X	Max. traversing speed (in m/s)	Max. scanning frequency of the measuring system (in kHz)	Min. counting frequency of the evaluation electronics without 4-edge evaluation (in MHz)	Min. counting frequency of the evaluation electronics with 4-edge evaluation (in MHz)
for C: A	10.00	500	0,75	3
for K: 0				

L Interpolation factor = 5

Value for X	Max. traversing speed (in m/s)	Max. scanning frequency of the measuring system (in kHz)	Min. counting frequency of the evaluation electronics without 4-edge evaluation (in MHz)	Min. counting frequency of the evaluation electronics with 4-edge evaluation (in MHz)
B	0.67	33	0.25	1
C	1.33	67	0.50	2
D	2.00	100	0.75	3
E	2.67	133	1.00	4
G	4.00	200	1.50	6
4	5.33	267	2.00	8
5	8.00	400	3.00	12
6	10.00	500	4.00	16

M Interpolation factor = 10

Value for X	Max. traversing speed (in m/s)	Max. scanning frequency of the measuring system (in kHz)	Min. counting frequency of the evaluation electronics without 4-edge evaluation (in MHz)	Min. counting frequency of the evaluation electronics with 4-edge evaluation (in MHz)
B	0.33	17	0.25	1
C	0.67	33	0.50	2
D	1.00	50	0.75	3
E	1.33	67	1.00	4
G	2.00	100	1.50	6
R	2.67	133	2.00	8
S	4.00	200	3.00	12
6	5.33	267	4.00	16
7	6.67	333	5.00	20
8	8.00	400	6.00	24

The listed values in the charts refer to a grating period (TP) of 20 µm.

I Interpolation factor = 25

Value for X	Max. traversing speed (in m/s)	Max. scanning frequency of the measuring system (in kHz)	Min. counting frequency of the evaluation electronics without 4-edge evaluation (in MHz)	Min. counting frequency of the evaluation electronics with 4-edge evaluation (in MHz)
B	0.13	7	0.25	1
C	0.27	13	0.50	2
D	0.40	20	0.75	3
E	0.53	27	1.00	4
G	0.80	40	1.50	6
R	1.07	53	2.00	8
S	1.60	80	3.00	12
T	2.13	107	4.00	16
U	2.67	133	5.00	20
V	3.20	160	6.00	24

N Interpolation factor = 50

Value for X	Max. traversing speed (in m/s)	Max. scanning frequency of the measuring system (in kHz)	Min. counting frequency of the evaluation electronics without 4-edge evaluation (in MHz)	Min. counting frequency of the evaluation electronics with 4-edge evaluation (in MHz)
B	0.07	3	0.25	1
C	0.13	7	0.50	2
D	0.20	10	0.75	3
E	0.27	13	1.00	4
G	0.40	20	1.50	6
R	0.53	27	2.00	8
S	0.80	40	3.00	12
T	1.07	53	4.00	16
U	1.33	67	5.00	20
V	1.60	80	6.00	24

P Interpolation factor = 100

Value for X	Max. traversing speed (in m/s)	Max. scanning frequency of the measuring system (in kHz)	Min. counting frequency of the evaluation electronics without 4-edge evaluation (in MHz)	Min. counting frequency of the evaluation electronics with 4-edge evaluation (in MHz)
B	0.03	2	0.25	1
C	0.07	3	0.50	2
D	0.10	5	0.75	3
E	0.13	7	1.00	4
G	0.20	10	1.50	6
R	0.27	13	2.00	8
S	0.40	20	3.00	12
T	0.53	27	4.00	16
U	0.67	33	5.00	20
V	0.80	40	6.00	24

The listed values in the charts refer to a grating period (TP) of 20 µm.

10.3 Scale Tape

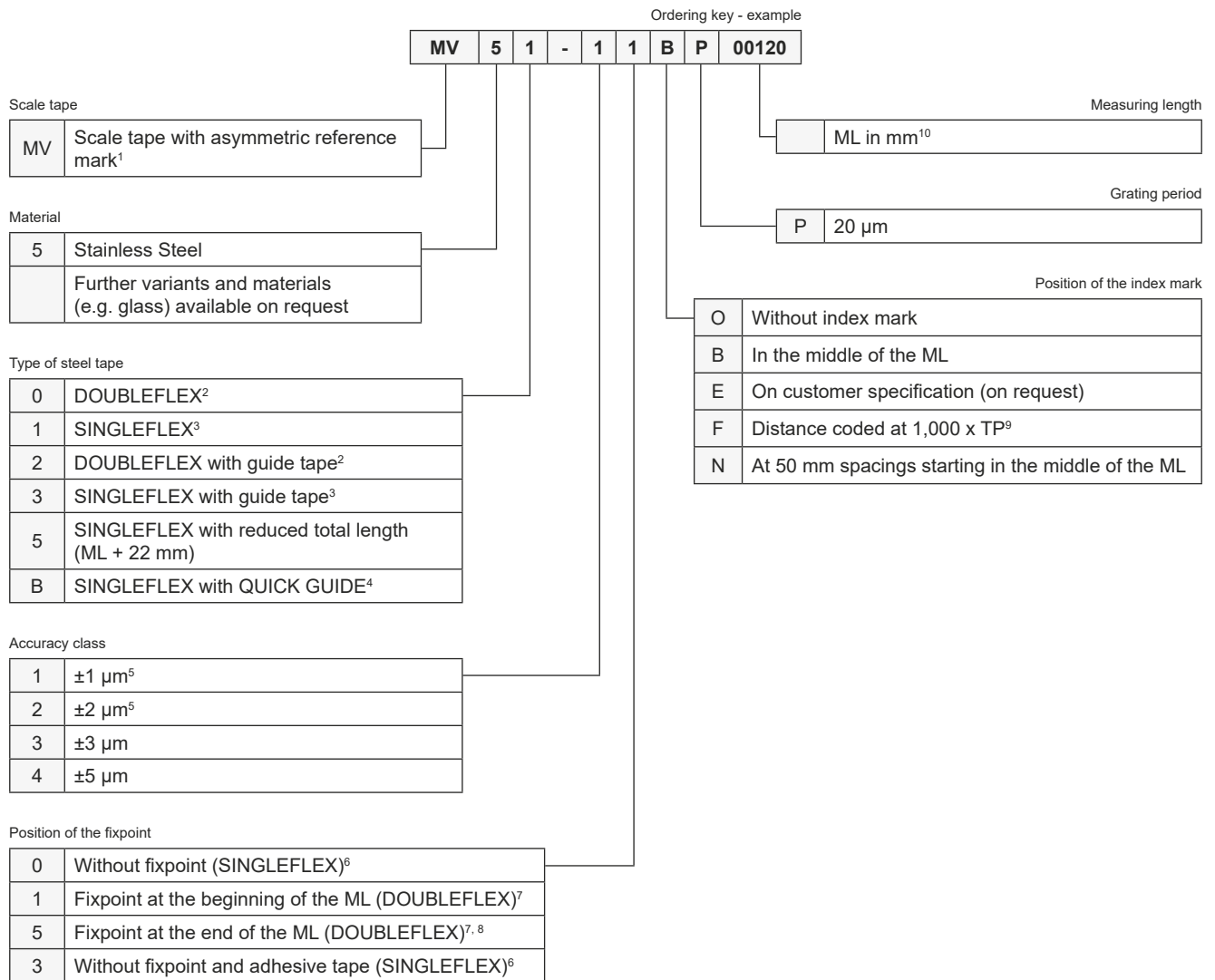

¹ This type is suitable for the following measurements systems with two-field scanning: LIA 20/21, LIK 21/22/23, Kit L2

² DOUBLEFLEX min. ML = 100 mm; max. ML = 5,000 mm

³ SINGLEFLEX max. ML = 30,000 mm

⁴ SINGLEFLEX with QUICK GUIDE max. ML = 1,950 mm

⁵ Max. ML = 500 mm

⁶ Only for SINGLEFLEX scale tape

⁷ Only for DOUBLEFLEX scale tape

⁸ Only for LIA 20

⁹ SINGLEFLEX max. ML = 8,750 mm / DOUBLEFLEX max. ML = 5,000 mm

¹⁰ Total length = ML + x (SINGLEFLEX x = 30 mm, DOUBLEFLEX x = 30 mm, QUICK GUIDE x = 52 mm)

ML - Measuring length

TP - Grating period

10.4 ADJUSTMENT TOOL

Name	Scope of delivery / Description	Order-no.
ADJUSTMENT TOOL	<ul style="list-style-type: none"> • ADJUSTMENT TOOL black box • Diagnostic cable to connect the measuring system • USB cable to connect a PC • USB - D-SUB - adapter cable (15-pin) • Exchangeable 8-pin plug connectors 	344220-33

Optional Single Components

Name	Description	Order-no.
EPIFLEX software - USB flash drive	External flash drive with saved EPIFLEX software	686802-02
USB - D-SUB - adapter cable (15-pin)	to supply the measuring system with voltage via PC	341693-0M
8-pin plug connector	to connect the diagnostic cable to the diagnostic socket	348958-01



USB - D-SUB - adapter cable (15-pin)

Image 23

Required components (not included):

- PC with OS Windows 7 / 8 (32 or 64 bit)



NUMERIK JENA GmbH

Im Semmicht 4
07751 Jena
Germany

Phone: +49 3641 4728-0

Fax: +49 3641 4728-202

E-Mail: info@numerikjena.de

www.numerikjena.de

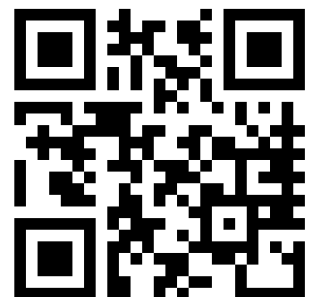

Version 01 2021

© & © NUMERIK JENA GmbH