

VZ Series L-VZ Series with extra large daylight

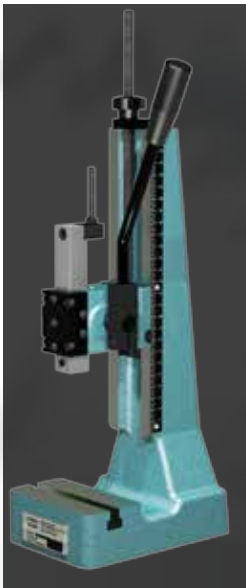

VZ 150-40



VZ 250-50

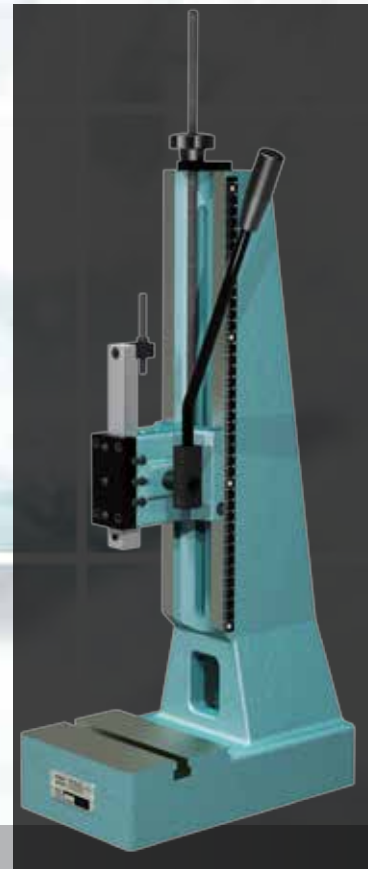

L-VZ 250-50

with extras
 HS - Return travel lock
 MICRO - Micrometer stop
 equipped with ERGO hand lever**

Type			VZ 150-40	VZ 150-90	VZ 250-50	VZ 250-100	L-VZ 250-50	L-VZ 250-100
Capacity		kN	1.5	1.5	2.5	2.5	2.5	2.5
Working stroke		mm	40	90	50	100	50	100
Throat	A	mm	63	63	80	80	80	80
Daylight	B	mm	35 - 235	35 - 235	42 - 290	42 - 290	55 - 390	55 - 390
Table size	CxD	mm	110 x 65	110 x 65	157 x 115	157 x 115	157 x 115	157 x 115
T-slot width similar to DIN 650		mm	10	10	12	12	12	12
Ram bore Ø x Depth	E	mm	10 ^{H7} x 25	10 ^{H7} x 25	10 ^{H7} x 25	10 ^{H7} x 25	10 ^{H7} x 25	10 ^{H7} x 25
Ram Ø	F	mm	20 x 20	20 x 20	20 x 20	20 x 20	20 x 20	20 x 20
Space requirement	CxG	mm	110 x 164	110 x 164	157 x 237	157 x 237	156 x 275	156 x 275
Stand height	K	mm	355	355	450	450	570	570
Weight		kg	ca. 8.5	ca. 8.5	ca. 21	ca. 21	ca. 29	ca. 29

Accessories (see Page 7)	Please specify when ordering.						
Return travel lock	HS	HS	HS	HS	HS	HS	HS
Micrometer stop	MICRO	MICRO	MICRO	MICRO	MICRO	MICRO	MICRO
Counter	Z	Z	Z	Z	Z	Z	Z
Table bore 12 ^{H7}	TB	TB	TB	TB	TB	TB	TB
Left/right-hander version*	R/L	R/L	R/L	R/L	R/L	R/L	R/L

The accessories

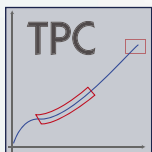
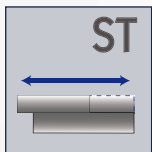
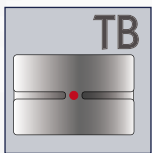
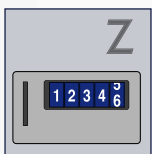
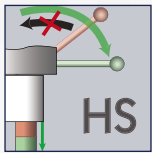

VZ range, L-VZ range with extra large daylight

The square ram has significant advantages compared with the round ram:

- ▶ Absolute protection against twisting
- ▶ Press ram guide free from play
- ▶ Readjustable guide rails for square ram
- ▶ Large tool locating surface
- ▶ Guides in tool therefore usually unnecessary
- ▶ Practically maintenance-free operation

mäder rack and pinion presses with square ram are ideal tools for manufacturing small precision parts with tight tolerances in small and medium-sized batches where automation would be too cost-intensive.

Manual lever with ergonomic user comfort

- ▶ Can be turned through 360°: adaptable for any body size and application.
- ▶ Lever angled to the side: free view of work area and ergonomically comfortable position.
- ▶ **R/L Version:** simple and easy conversion for left-handers without losing the tool setting. Ideal for job sharing on one press.



Manual lever can be refitted for right- and left-handers

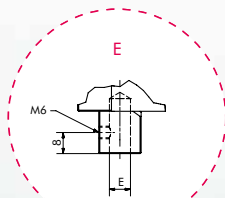

VZ 150

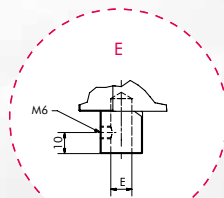

VZ 250

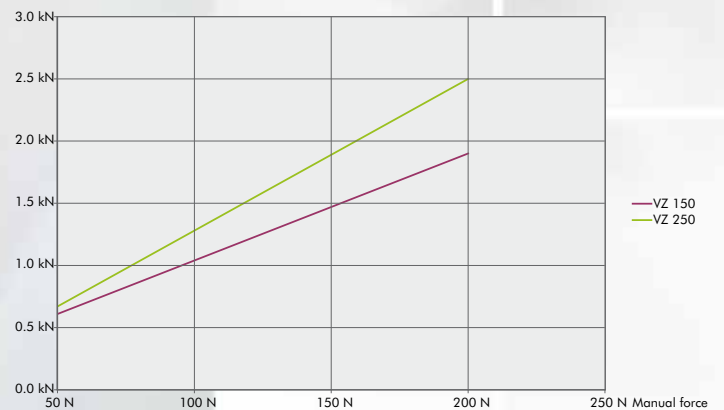
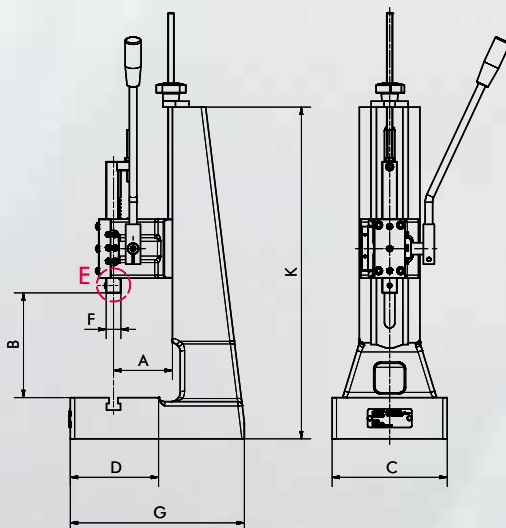

Pictograms in the catalogue show which accessories are possible for which presses.

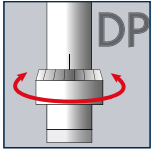

Precision ram adjustment (DP)

As toggle presses do not achieve their maximum force until BDC, adjusting the height of the press head by means of the threaded spindle is often too inaccurate. The precision ram adjustment enables the press pressure point to be precisely set directly at the ram. The scale on the adjustment ring enables the fine setting to be read off to 0.02 mm. The adjustment range is ± 1.5 mm. The precision ram adjustment is used when the utmost precision is required for the press depth. Ideal for prototype manufacture and serial production when accurate and easy adjustment within the tolerance range is required.



Micrometer stop (MICRO)

The micrometer stop is used with rack and pinion presses for high-precision assembly work or for when the tool has to be accurately positioned. This enables the press stroke length to be accurately adjusted to 0.01 mm

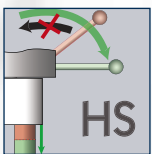

Return travel lock (HS)

The return travel lock for toggle and rack and pinion presses is an effective contribution to quality assurance during production. The return travel lock rules out partial strokes and therefore incomplete operations. Forming, assembly and joining operations are always reliably and completely executed, as the return stroke of the press is blocked on the downward stroke. The interlock is only released and the lever can only be returned when the stroke is complete. The Quick-Release mechanism enables this inhibit to be released and jammed parts to be removed in any position. The Quick-Release is automatically deactivated when the lever is returned.

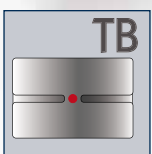
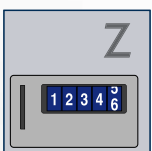
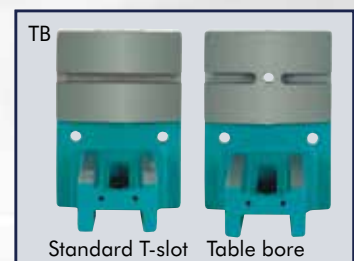

Table bore (TB)

The bottom part of the tool can be mounted in the centric table bore. Fixing is by means of a transverse screw in all models up to 80 mm throat. The table bore enables the tool to be changed quickly and reduces set-up time. The alignment accuracy of the ram bore with the table bore is < 0.05 mm.



Stroke counter (Z)

A rapid overview of the number of items produced can be obtained with the five-digit stroke counter. The number of items can be reset.

